

ON POWER STREAM IN MOTOR OR DRIVE SYSTEM

Zygmunt Paszota, Prof.

Gdansk University of Technology, Poland

ABSTRACT

In a motor or a drive system the quantity of power increases in the direction opposite to the direction of power flow. Energy losses and energy efficiency of a motor or drive system must be presented as functions of physical quantities independent of losses. Such quantities are speed and load. But the picture of power stream in a motor or drive system is presented in the literature in the form of traditional Sankey diagram of power decrease in the direction of power flow. The paper refers to Matthew H. Sankey's diagram in his paper „The Thermal Efficiency of Steam Engines” of 1898. Presented is also a diagram of power increase in the direction opposite to the direction of power flow. The diagram, replacing the Sankey's diagram, opens a new prospect for research into power of energy losses and efficiency of motors and drive systems.

Keywords: motors, drive systems, energy losses, energy efficiency, Sankey diagram, new research field

INTRODUCTION

Energy losses and energy efficiency of a motor or drive system should be presented as dependent on the physical quantities independent of the losses. Such independent quantities are speed and load of the motor shaft required by the machine or device driven by the motor. The momentary speed and load decide on the momentary motor useful power and, in a different way, on the kinds and momentary quantities of the losses. However, the energy losses and energy efficiency of motors are determined by researchers and manufacturers as dependent on physical quantities which depend on the losses. For instance, the energy efficiency of motors used in hydrostatic drive are presented as dependent on the flow intensity of motor feeding liquid and on the decrease of pressure in the motor. A reason of such situation is the traditional, commonly accepted and used, but unfortunately erroneous picture of power stream in the motors and drive systems, presented in the literature by means of the Sankey diagram of power decrease in the direction of power flow [2, 3].

DRIVE INVESTIGATIONS CARRIED OUT BY MATTHEW H. SANKEY

Matthew H. Sankey was an Irish mechanical engineer and captain in the Corps of Royal Engineers where he did research into increase of energy efficiency of steam engines. He was a member of the British Institution of Civil Engineers. His extensive paper *The Thermal Efficiency of Steam Engines* where he presented diagrams of power flow in a drive system, was published in the „Minutes of Proceedings of the Institution of Civil Engineers” in 1898. In 1899, Journal of the American Society of Naval Engineers, under the title *The Thermal Efficiency of Steam Engines*, concluded: „One of the most important engineering papers published in recent years was the report of the committee appointed by the Institution of Civil Engineers to consider and report to the council upon the subject of the definition of a standard or standards of thermal efficiency for steam engines. We print the main portion below as given in the Proceedings of the above society” [1].

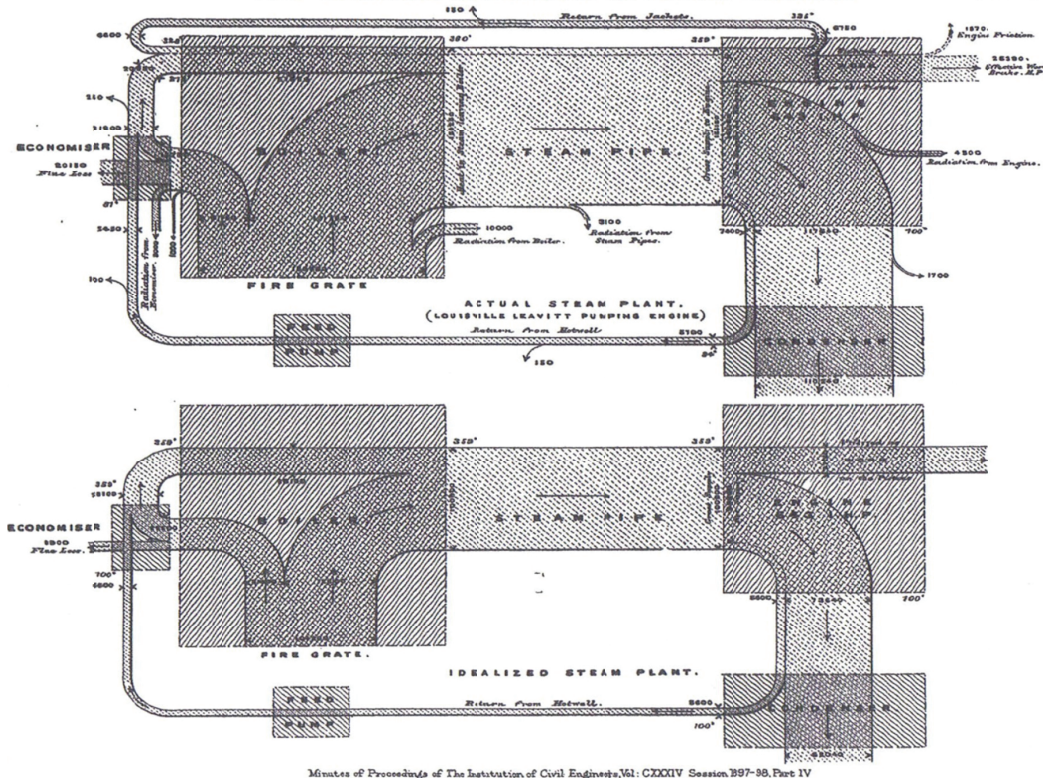

Fig. 1. Diagrams of power decrease in steam plant (actual and idealized) investigated by Sankey, presented in [1]

In his paper, Sankey presented two diagrams of power flow in the investigated, actual and idealized, steam plants. The diagrams are shown in Fig.1.

Sankey writes about the diagrams:

„The boiler, the engine, the condenser and air pump, the feed pump and economizer, are indicated by rectangles upon the diagram. The flow of heat is shown as a stream, the width of which gives the amount of heat entering and leaving each part of the plant per unit of time; the losses are shown by the many waste branches of the stream. Special attention is called to the one (unfortunately small) branch which represents the work done upon the pistons of the engine”.

In the case of smaller power losses which occur in the idealized steam plant, Sankey shows slight increase of useful power of the engine and also decrease of power consumed by the engine (in steam pipe) and decrease of power consumed by the boiler. In effect, the energy efficiency of steam plant is increased.

From the power flow diagrams in Fig. 1 and from the above quoted Sankey’s comment, it may be concluded that power losses are treated as wasted branches of the main stream and weakening that stream and also that „the work (per unit of time) done upon the pistons of the engine” results from power consumed by the system and powers of losses in the system.

The diagram of power stream in a drive system, adopted by Sankey, is probably an effect of his concentration on the decrease of the main stream of power in the direction of power flow due to energy losses in the system, wasted and abstracted outwards.

It can be noticed in Sankey diagrams of Fig. 1, that the quantity of energy losses in a drive system changes depending on the system quality even when the system useful power practically does not change.

Therefore it may be assumed that, depending on whether we deal with an actual or an idealized system, with the same physical quantities describing the drive system useful power (e.g. the same motor shaft speed and load), the consumed input power will change with the power of energy losses.

It may also be assumed that the quantity of input power consumed by the system will be determined by the required output useful power and powers of energy losses in the system, related to its quality.

However, with the Sankey diagram one cannot present energy losses in a drive system as dependent on physical quantities deciding on the system output useful power, present the input consumed power as dependent on the output useful power or describe mathematically the system power of energy losses and energy efficiency as dependent on the motor speed and load in the system.

Maybe, Sankey in his considerations did not feel a need to describe mathematically the relations of energy losses in a motor or drive system or the relations of energy efficiency to the physical quantities deciding on them.

A simplified diagram of power stream in a motor or drive system, referring to the Sankey diagram, has the form presented in Fig. 2.

In accordance with Fig. 2 the motor (drive system) useful (output) power P_u results from a difference of the consumed

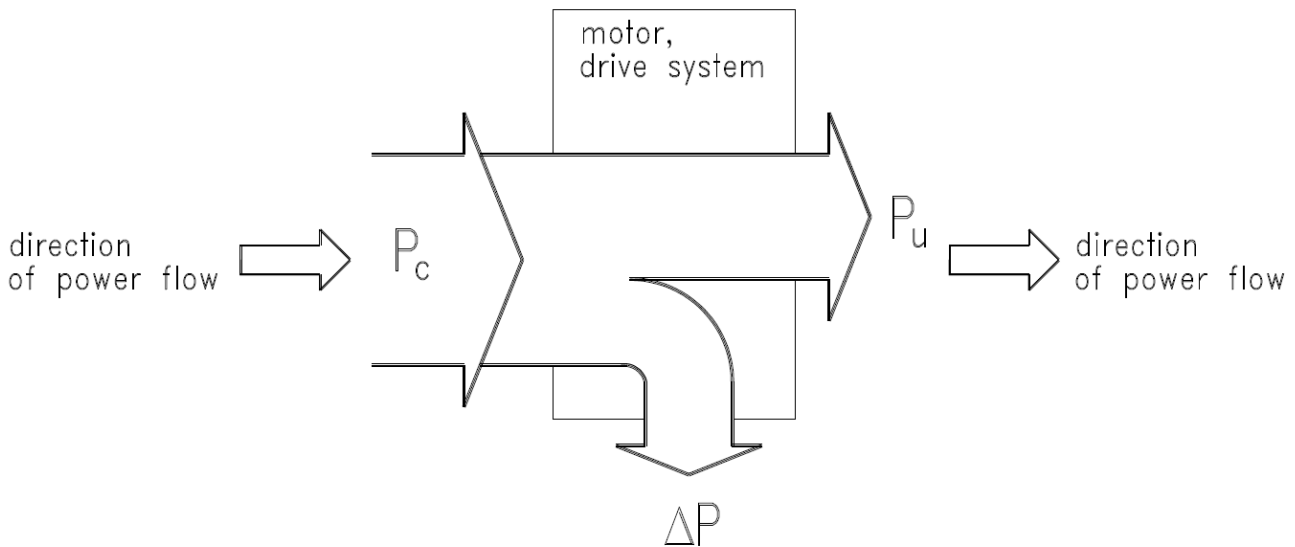

Fig. 2. Simplified diagram of decrease of power in motor or drive system in the direction of power flow, referring to Sankey diagram in Fig. 1
 P_c - the consumed (input) power expressed in [W], P_u - the useful (output) power [W], ΔP - the power of losses [W].

(input) power P_c and power of losses, ΔP :

$$P_u = P_c - \Delta P. \quad (1)$$

A consequence of (1) is connection between the power of energy losses, ΔP , and the consumed power P_c , and description of the motor or drive system energy efficiency η in the form:

$$\eta = \frac{P_u}{P_c} = \frac{P_c - \Delta P}{P_c} = 1 - \frac{\Delta P}{P_c}. \quad (2)$$

Formula (2), related to the power decrease diagram in Fig. 2, describing the energy efficiency η , allows only to determine the effectiveness of the use of the consumed power P_c in a motor or drive system.

The Sankey diagram and the resulting formulae (1) and (2) do not fully describe the physical phenomena occurring in a drive system.

The energy losses, e.g. mechanical, volumetric, pressure losses in a motor or drive system, are abstracted outwards in the form of heat. However the different losses depend on the physical quantities deciding directly about them. Simultaneously power of the losses enforces an increase of power stream at the inlet to the system element where they occur in order to overcome them. The useful power of a drive system must result from the power required from the system by a machine or device driven by it.

The diagram of power stream in a motor or drive system should show the physical quantities directly or indirectly deciding on the values of individual losses. Mathematical descriptions of the losses should allow to formulate descriptions of the resulting energy efficiencies. The product of individual efficiencies decides of the energy efficiency of elements and, in effect, of the drive system overall efficiency. However the

Sankey diagram does not give such possibility.

DIAGRAM OF POWER INCREASE OPPOSITE TO THE DIRECTION OF POWER FLOW

Evaluation of the energy behaviour of different kinds and sizes of motor or drive systems requires their energy efficiencies to be described and compared as dependent on the motor shaft or piston rod speed coefficient $\bar{\omega}_M$ and load coefficient \bar{M}_M changing in its operation field ($0 \leq \bar{\omega}_M < \bar{\omega}_{Mmax}$, $0 \leq \bar{M}_M < \bar{M}_{Mmax}$, respectively). Maximum values of the speed coefficient $\bar{\omega}_{Mmax}$ and load coefficient \bar{M}_{Mmax} result from the drive system maximum capacity and the losses, and they outline the operating field limits. Fig. 3 presents the motor operating field in a drive system.

The current angular speed ω_M (rotational speed n_M) required from a rotational hydraulic motor or the linear speed v_M required from a linear hydraulic motor (hydraulic cylinder), operating in a hydrostatic drive system, are replaced, in mathematical models of the energy losses and energy efficiency, by the motor speed non-dimensional coefficient $\bar{\omega}_M$:

$$\bar{\omega}_M = \frac{\omega_M}{\omega_{Mt}} = \frac{n_M}{n_{Mt}} = \frac{\omega_M q_{Mt}}{2\pi Q_{Pt}} = \frac{n_M q_{Mt}}{Q_{Pt}}, \quad (3)$$

or

$$\bar{\omega}_M = \frac{v_M}{v_{Mt}} = \frac{v_M S_M}{Q_{Pt}}. \quad (4)$$

The rotational motor theoretical angular speed ω_{Mt} (rotational speed n_{Mt}) is treated as a constant reference value for the motor current angular speed ω_M (rotational speed n_M). The value ω_{Mt} (n_{Mt}) results from the quotient of the theoretical pump capacity Q_{Pt} and the theoretical motor absorbing capacity q_{Mt}

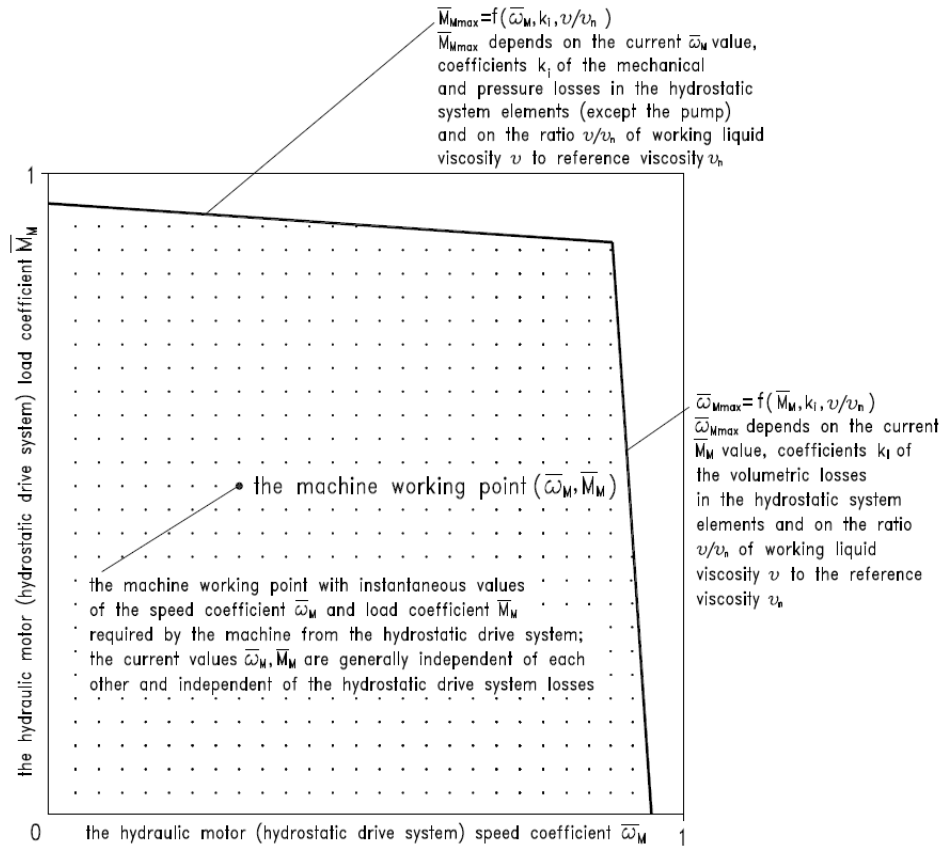

Fig. 3. The range of the motor speed coefficient $\bar{\omega}_M$ and load coefficient \bar{M}_M ($0 \leq \bar{\omega}_M < \bar{\omega}_{Mmax}$, $0 \leq \bar{M}_M < \bar{M}_{Mmax}$, respectively) in a hydrostatic drive system [2]

per one shaft revolution.

The linear motor theoretical speed v_{Mt} is treated as a constant reference value for the motor current speed v_M . The value v_{Mt} results from the quotient of the theoretical pump capacity Q_{Pt} and the motor piston area S_M .

The current torque M_M required from a rotational motor or the current force F_M required from a linear motor, operating in a hydrostatic drive system, are replaced by the motor load non-dimensional coefficient \bar{M}_M :

$$\bar{M}_M = \frac{M_M}{M_{Mt}} = \frac{2\pi M_M}{q_{Mt} p_n}, \quad (5)$$

or

$$\bar{M}_M = \frac{F_M}{F_{Mt}} = \frac{F_M}{S_M p_n}. \quad (6)$$

The rotational motor theoretical torque M_{Mt} is treated as a constant reference value for the motor current torque M_M . The value M_{Mt} results from the product of the system nominal pressure p_n (in the pump outlet conduit) and the motor theoretical absorbing capacity q_{Mt} per one shaft revolution.

The linear motor theoretical force F_{Mt} is treated as a constant reference value for the motor current force F_M . The value F_{Mt} results from the product of system nominal pressure p_n and the motor piston area S_M .

A simplified diagram of power stream, showing an impact of the useful power P_u , i.e. an impact of speed and load of shaft

or piston rod, on the power ΔP of energy losses in motor or drive system, and in effect on the increase of power in the direction opposite to the direction of power flow and on the consumed power P_c , is presented in Fig. 4.

In a motor or drive system, the quantity of power increases in order to overcome the power of energy losses, in the direction opposite to the direction of power flow.

The useful (output) power P_u of motor or drive system operating in the ($0 \leq \bar{\omega}_M < \bar{\omega}_{Mmax}$, $0 \leq \bar{M}_M < \bar{M}_{Mmax}$) field, is independent of the losses power ΔP in the motor or drive system, and it results from momentary values of the speed coefficient $\bar{\omega}_M$ and load coefficient \bar{M}_M required by the driven device:

$$P_u = f(\bar{\omega}_M, \bar{M}_M). \quad (7)$$

The losses power ΔP of in the motor or drive system depends on the system structure and quality of its components and, in a different way, on momentary values of the motor speed coefficient $\bar{\omega}_M$ and load coefficient \bar{M}_M changing in the ($0 \leq \bar{\omega}_M < \bar{\omega}_{Mmax}$, $0 \leq \bar{M}_M < \bar{M}_{Mmax}$) range, respectively:

$$\Delta P = f(\bar{\omega}_M, \bar{M}_M). \quad (8)$$

The consumed (input) power P_c of motor or drive system results from the sum of the useful power P_u and losses power

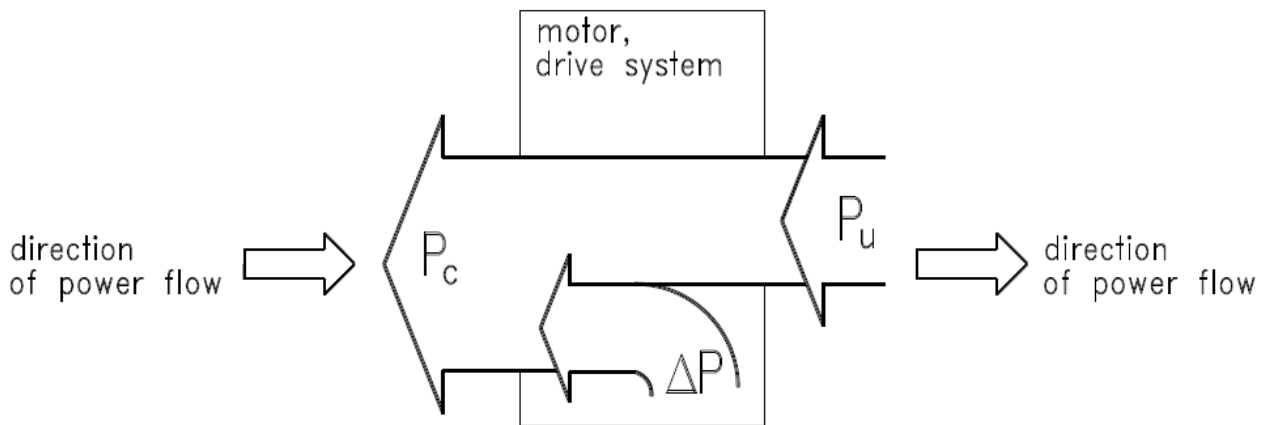

Fig. 4. Simplified diagram of the increase of power in motor or drive system opposite to the direction of power flow, replacing the Sankey diagram presented in Fig.1

ΔP of:

$$P_c = P_u + \Delta P = f(\bar{\omega}_M, \bar{M}_M). \quad (9)$$

A consequence of (8) and (9) is description of the motor or drive system energy efficiency η as dependent on $\bar{\omega}_M$ and \bar{M}_M :

$$\eta = \frac{P_u}{P_c} = \frac{P_u}{P_u + \Delta P} = \frac{1}{1 + \frac{\Delta P}{P_u}} = f(\bar{\omega}_M, \bar{M}_M). \quad (10)$$

Formula (10) describing the energy efficiency η , in comparison with formula (2), allows not only to determine the effectiveness of the use of the power P_c consumed in the motor or drive system, but also to describe mathematically the dependence of the momentary value of the useful power P_u , losses power ΔP and, in effect, the consumed power P_c and momentary value of the energy efficiency η on the speed coefficient $\bar{\omega}_M$ and load coefficient \bar{M}_M of the motor shaft or piston rod.

In the hydrostatic drive [4], energy investigations of pump and hydraulic motor as independent machines consist in determination of the pressure coefficients k_i , volumetric and mechanical losses. The coefficients k_i are used in mathematical descriptions of the relations of individual losses to the physical quantities directly deciding on them. The pressure, volumetric, mechanical and overall energy efficiency characteristics of the machines in question are determined in parallel with evaluation of the overall efficiency of a hydrostatic system where they are used. Knowledge of the values of the coefficients k_i of losses in elements of hydrostatic system allows to obtain, by using a numerical method, the pump efficiencies: η_{pp} , η_{pv} , η_{pm} and η_p , hydraulic motor efficiencies: η_{Mp} , η_{Mv} , η_{Mm} and η_M , conduit efficiency η_c , throttling control assembly (if it is used) structural efficiency η_{st} and the hydrostatic drive system overall efficiency η in function of $\bar{\omega}_M$ and \bar{M}_M , in the hydraulic motor (hydrostatic system) operating field ($0 \leq$

$\bar{\omega}_M < \bar{\omega}_{Mmax}$, $0 \leq \bar{M}_M < \bar{M}_{Mmax}$) and at a selected value of the ratio v/v_n of the hydraulic oil viscosity v and the reference viscosity v_n . The proposed method is precise by definition and simple in use. It simplifies the laboratory investigation of pumps, hydraulic motors and hydrostatic drive systems. It allows to seek for energy - saving structures of hydrostatic drive system.

CONCLUSION

From the diagrams of power decrease in a steam plant investigated by Sankey and from the Sankey's comment it may be concluded that power losses are treated as wasted branches of the main stream and weakening that stream and also that „work (per unit of time) done upon the pistons of the engine” results from power consumed by the system and powers of losses in the system. The diagram of power stream in the drive system, adopted by Sankey, was probably an effect of his concentration on the decrease of main power stream in the direction of power flow, caused by energy losses in the system, which are wasted and abstracted outwards.

However, referring to Sankey diagrams for an actual and idealized steam plant it can be noted that the level of energy losses in a drive system changes depending on the system quality even when the system useful power remains practically unchanged.

Therefore it may be concluded that, depending on whether we consider an actual or idealized system, the input consumed power, with the same physical quantities describing the drive system useful output power (e.g. the same motor shaft speed and load), will change as dependent upon the power of energy losses in the system.

Also, it may be concluded that the input power consumed by system will be decided by output useful power and powers of energy losses related to the system quality.

However, using the Sankey diagram, one can not present

the drive system energy losses as dependent on the physical quantities deciding on the system output useful power, present the relation of the input consumed power to the output useful power or describe mathematically the powers of energy losses and system energy efficiency as dependent upon the speed and load of motor in the system.

Description of the motor or drive system energy efficiency η , obtained from the Sankey diagram, allows only to determine the effectiveness of the use of consumed power.

The Sankey diagram does not describe in full the physical phenomena occurring in a drive system.

In a motor or drive system, the quantity of power increases in order to overcome the power of energy losses, in the direction opposite to the direction of power flow.

The useful (output) power of a motor or drive system working in the operating field ($0 \leq \bar{\omega}_M < \bar{\omega}_{Mmax}$, $0 \leq \bar{M}_M < \bar{M}_{Mmax}$), is independent of the powers of losses in the motor or drive system and results from the momentary values of the speed coefficient $\bar{\omega}_M$ and load coefficient \bar{M}_M required by the driven device.

Power of energy losses in a motor or drive system depends on the system structure and quality of its elements and, in a different way, on the momentary values of the motor speed coefficient $\bar{\omega}_M$ and load coefficient \bar{M}_M changing in the ($0 \leq \bar{\omega}_M < \bar{\omega}_{Mmax}$, $0 \leq \bar{M}_M < \bar{M}_{Mmax}$) range, respectively.

The proposed formula (10), describing the energy efficiency η , allows not only to determine the effectiveness of the use of power consumed in a motor or drive system, but also to describe mathematically the relations of momentary value of useful power, power of losses and, in effect, consumed power and momentary value of energy efficiency to the motor shaft (or piston rod) speed coefficient $\bar{\omega}_M$ and load coefficient \bar{M}_M changing in the ($0 \leq \bar{\omega}_M < \bar{\omega}_{Mmax}$, $0 \leq \bar{M}_M < \bar{M}_{Mmax}$) range, respectively.

The proposed diagram of power increase opposite to the direction of power flow in a motor or drive system, replacing the Sankey diagram, opens a new prospect for research into power of energy losses and efficiency of motors and drive systems.

Reference [4] presents a proper and complete view of the energy losses and energy efficiency of a hydrostatic drive system. It is an example to be followed in other types of drive. It allows to compare objectively the energy efficiencies of different drives.

BIBLIOGRAPHY

1. Sankey M. H.: *The Thermal Efficiency of Steam Engines*. „Minutes of Proceedings of the Institution of Civil Engineers”. CXXXIV (1897 - 1898, Part IV). Reprint in Journal of the American Society of Naval Engineers. Vol. XI.NO.4. November, 1899. pp. 949 ÷975. (Retrieved from University of Michigan)
2. Paszota Z.: *Losses and energy efficiency of drive motors and systems. Replacement of the Sankey diagram of power decrease in the direction of power flow by a diagram of power*

increase opposite to the direction of power flow opens a new perspective of research of drive motors and systems. Polish Maritime Research 1/2013

3. Feature/Eastern Europe: *Driving a new perspective. Professor Zygmunt Paszota, faculty of ocean engineering and ship technology, Gdansk University of Technology, Poland, explains a new approach to the Sankey Diagram for drive motors*. The Naval Architect, May 2013, pp. 72 ÷ 76,
4. Paszota Z.: *Energy losses in hydrostatic drive. Drive investigation method compatible with diagram of power increase opposite to the direction of power flow*. LAP LAMBERT Academic Publishing, 2016

CONTACT WITH THE AUTOR

Zygmunt Paszota

e – mail: zpaszota@pg.gda.pl

Gdansk University of Technology
11/12 Narutowicza St.
80-233 Gdansk
Poland

POLAND