

## TECHNOLOGY CONCEPT OF TLP PLATFORM TOWING AND INSTALLATION IN WATERS WITH DEPTH OF 60 M

Czesław Dymarski  
Paweł Dymarski  
Jędrzej Żywicki  
Gdansk University of Technology, Poland

### ABSTRACT

*The article is part of the design and research work conducted at the Gdansk University of Technology, Faculty of Ocean Engineering and Ship Technology, in cooperation with a number of other research centres, which concerns offshore wind farms planned to be built in the Polish zone of the Baltic sea in the next years. One of most difficult tasks in this project is building suitable foundations for each power unit consisting of a tower and a wind turbine mounted on its top. Since the water regions selected for building those wind farms have different depths, there was need to study different possible technical variants of this task, with the reference to both the foundation structures themselves, and the technology of their transport and setting, or anchoring. The article presents the technology of towing, from the shipyard to the setting place, and installation of the foundation having the form of a floating platform of TLP (Tension Leg Platform) type, anchored by tight chains to suction piles in the waters with depth of 60 m.*

**Keywords:** platform anchoring, towing, TLP platform installation

### INTRODUCTION

The permanently increasing demand for energy, with simultaneous dwindling of the world's fossil energy sources, leads to growing interest in acquiring energy from renewable sources and from various unconventional sources, such as waste materials for instance [1]. Along with that, higher and higher attention is paid to rational energy use, which makes combined energy generation systems and hybrid drives become very attractive and worth studying [2]. Here, special attention is given to the efficiency of the energy production methods and their impact on the environment [3,4].

A renewable energy source which is ecological and available in all countries is the wind. That is why the development of windpower engineering is very dynamic, although this energy

source is not equally reach in different areas and, what is more, reveals high variability of parameters [5]. Here, the areas of interest refer to selecting most favourable types and dimensions of wind turbines and their control systems, and finding places with relatively high and stable wind speeds, preferably situated far from residential areas. Such favourable conditions are observed at sea, and therefore a large number of maritime countries have made decisions to build offshore farms of wind power stations [6,7]. However, these projects are very difficult and require solving numerous complex problems, with the resultant high costs involved, particularly the investment cost. The most difficult problems refer to wind turbine foundations, bearing the name of supporting structures, on which the towers with wind turbines are

mounted. Types of these structures, as well as the level of difficulties and costs of their design, necessary tests, production, transport, and installation, mainly depend on the depth of the water region in which they are to be installed [8,9]. In general, the supporting structures used in the waters with depth not exceeding 40 m have the form of founded supports, such as, for instance, mono-piles, and jacked or triode type platforms [10], while in deeper waters, standard floating platforms are in common use [6].

The article presents the technology of towing and anchoring (installation) of a TLP-type floating platform intended to work as the supporting structure on which the tower with wind turbine will be installed. Selecting the type of platform and the method of its anchoring was preceded by the analysis of the research results published in [11,12,13,14]. It also based on personal experience gained by the authors in their past research, and on the results obtained by them.

The platform, shown in Fig. 1 as ready for towing, is planned to be installed on the Baltic sea, in waters with depth of 60 m. The basic structural elements of this platform are the hull and the column, on which the tower with the 6 MW wind turbine will be mounted. The turbine axis is assumed to be at the height of 90 m above sea level. The 10-meter high tripod hull of the platform, shown in Fig. 1, will be submerged in the water in such a way that its bottom surface will be 40 m above the seabed, while the upper flange of the column will protrude 15 m above the sea level. Each arm of the hull will be connected, via tight anchor chains, to one of the three suction piles set in the seabed. Further in the article, successive steps of platform installation, including its preparing, towing, and anchoring at the destination place, are discussed.

## PREPARING THE PLATFORM FOR TOWING

It is assumed that the platform will be built in one of shipyards situated in Gdansk or Gdynia. A more detailed description of the structure, with drawings and strength analyses, will be provided in a separate article prepared for publication. The platform is planned to be equipped with the basic ballast system adapted for cooperation with an external pump unit.

The platform will be able to be installed and anchored using a number of different systems. For each system, a different structural solution was designed in the end parts of the arms in the underwater hull section. The system of platform anchoring which is described in this article makes use of six vertical tight anchor chains, mounted in pairs at each end of the three platform hull arms, as shown in Fig. 1. These chains are planned to be installed on the platform at the shipyard before towing. The upper chain parts will be fixed to the platform arms using a ratchet stopper and a tension wedge, which will facilitate the assembly and provide opportunities for better distribution of chain forces into the fastening elements and the arm structure. Before towing, special lugs or chain stoppers and rope pulleys will be installed on the upper surfaces of the platform arms, near the column, while a

removable protection cap with cylindrical part covered with polyamide, or a set of two wide chain rollers for directing the anchor chain during its lowering, will be mounted at each arm end edge. In the latter case, two smaller rope pulleys, intended to be used for auxiliary works, will be installed between the two chain rollers. Parts of arm surfaces on which the chains are expected to be laid should be covered with wooden boards, or other type of facing to protect the hull plating from direct contact with the chain. Once this preparatory work is done, lower parts of the chains will be lifted, one by one, by a crane and, after embracing front arm surfaces with protecting facing or pulleys, will be arranged along the arms, on the upper arm surfaces. The end link of each chain will be fastened with a pin to the lug or chain stopper situated close to the platform column. The method of chain attachment to the platform column is schematically illustrated in Figs. 1 and 2. It is expected that in this attachment method, part of the chain of about 8 m in length will hang down under the platform bottom to the approximate depth of 4 m. It has been assessed in preliminary calculations that the platform draught during towing will be  $h_0 = \sim 3\text{m}$ , while the height of its centre of gravity will be  $h_{sc} = \sim 8\text{m}$ , all this ensuring good platform stability during the towing operation.

Vertical fragments of small-diameter pipes (not shown in Fig. 1) will be fastened to the side walls of the arm ends. These pipe fragments will be used for guiding lines for remote releasing or locking of the mechanisms connecting the chains with the anchor piles shown in Fig. 5.

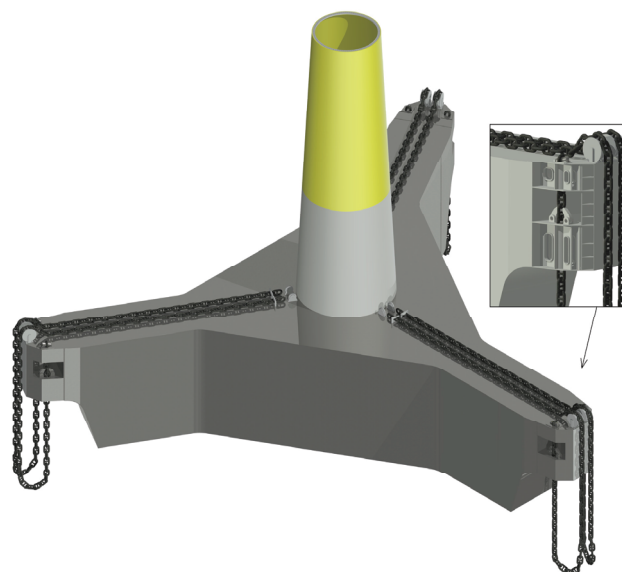

Fig. 1. Simplified isometric drawing of the platform prepared for towing. The enlarged section shows the method of fastening of upper anchor chain ends to the platform arm.

## PREPARING THE SEABED FOR PLATFORM ANCHORING

Preparing the seabed for anchoring of a TLP-type platform requires numerous evaluative and research studies in order

to assess possible extreme sea conditions (wind, waves, sea currents, temperature changes), as well as to identify the structure and strength of the seabed [15,16], the effect of platform foundation installation on the environment, and the economic and technical conditions. In the present case, the analysis was limited to technical and, to some extent, economic issues which allowed to select most profitable devices and technologies.

Anchoring of the TLP-type platform is characterised by the appearance of extremely high loads, mainly in vertical direction, acting on the elements anchored in the seabed [17, 18, 19, 20]. Constructional elements which best carry this type of load are piles, driven into the seabed or introduced using the suction method. The type of the applied pile and its geometrical parameters depend on numerous factors, in particular on the expected loads, the seabed structure [21], the water region depth, as well as on the available specialised units and the cost of their service. In the present case, taking into account the abovenamed factors, a preliminary decision was made to use suction piles. Decisive arguments for this choice included relatively short time of piling, and favourable shapes and proportions of pile dimensions, large diameter in particular, thanks to which two anchor chains will be able to be fastened to each pile. Precise evaluation of geometrical and strength parameters of the piles, and selection of a specialised unit with the equipment needed for driving them into the seabed will be discussed in a separate article. Based on preliminary calculations performed for the assumed type of soil (fine sand), depth of 60 m, and the required vertical component of the holding force, the pile diameter was assessed as equal to  $D = 5\text{ m}$  and the length equal to  $L = 18\text{ m}$ . The pile positions in the seabed should correspond as precisely as possible to the platform position, for the anchor chain pipe axes in the platform hull arms to coincide with the axes of the fastening mechanisms, mounted on the pile to which the anchor chains will be fastened (their displacement should not exceed  $\sim 0,10\text{ m}$ ). To facilitate the operation of fastening the lower chain end to the lug on the pile, these mechanisms will have in their upper part simple leading constructions, for the end link of the lowered chain to settle automatically in a relevant seating of the mechanism and to take the correct position for introducing the pin connecting it with the lug (see Fig. 5)

It is planned to install a control lever on the mechanisms connecting the anchor chain with the pile. This lever will be able to be operated directly by a diver, or remotely via a thin control cord, the upper end of which will be temporarily fixed to a small buoy floating on the sea surface. Upon request of the owners, a remote cordless system for switching on the above mechanism can also be provided.

## TOWING

An assumption has been made that the towing operations can be performed when the sea state does not exceed 4 on the Beaufort scale and the wind speed does not exceed  $W = 8\text{ m/s}$ .

The towrope will be fastened at the height of 4 m above the platform bottom, i.e. about 1 m above the sea surface. For the towing speed of  $V = 2\text{ m/s}$  with respect to water and the opposite wind direction, the required towrope force is equal to  $F_h = 380\text{ kN}$ . The highest overturning moment acting on the towed platform  $M_w = 970\text{ kNm}$  will occur for the above maximal towing and wind speeds, but for the same wind direction as the towing direction. The platform should be towed by at least two tug units, one towing and one dragged unit, both connected with the platform via ropes in the way accepted by classification societies. The calculated stability of the towed platform in the above defined conditions is sufficiently high to ensure its safe delivery to the anchoring place.

## PREPARING THE PLATFORM FOR ANCHORING – LOWERING ANCHOR CHAINS

When the platform reaches the anchoring place, but before keeping it precisely in the final position, subsequent anchor chains can be lowered.

This operation can be executed in two ways:

- with the assistance of three tugs,
- with the assistance of a specialist vessel.

Further in the article, only the latter method is described in detail.

Using a specialist vessel for chain lowering is considered justified, as this vessel is also planned to be used in other, frequently more difficult, dangerous and expensive operations, such as platform ballasting and anchoring.

In authors' opinion, this vessel should have a properly shaped hull in the stern section and two azimuth propellers for precise position keeping. It should be equipped with a slewing deck crane and a set of six hydraulic servomotors for connecting the vessel with the platform column, as shown in a simplified way in Figs. 2, 3 and 4. It should also have a properly trained crew and other specialist equipment for performing technical operations on the vessel or platform, or certain underwater actions. This vessel is also planned to be used in further operations of platform installation, which will be discussed in the next Chapters. For the purpose of chain lowering, at least two technical servicemen should be brought onto the platform hull.

The vessel comes up to the platform and moors with its stern between the platform arms in the way shown in Fig. 2, for the crane jib to be able to reach over the entire surface of the platform hull arm. The crane operator sets the jib in proper position and lowers the rope with the hook to the place of chain fastening to the lug (or stopper) on the platform hull.

People on the platform hull connect the hook lowered with the rope to the end of the laying chain, at the lug (or stopper) to which it was fixed. The crane operator slowly heaves the rope with the hook to tighten it slightly, then the servicemen on the platform pull out the pin connecting the end chain link with the lug (or release the stopper) on the hull. At the same time the crane operator, manoeuvring with the jib and

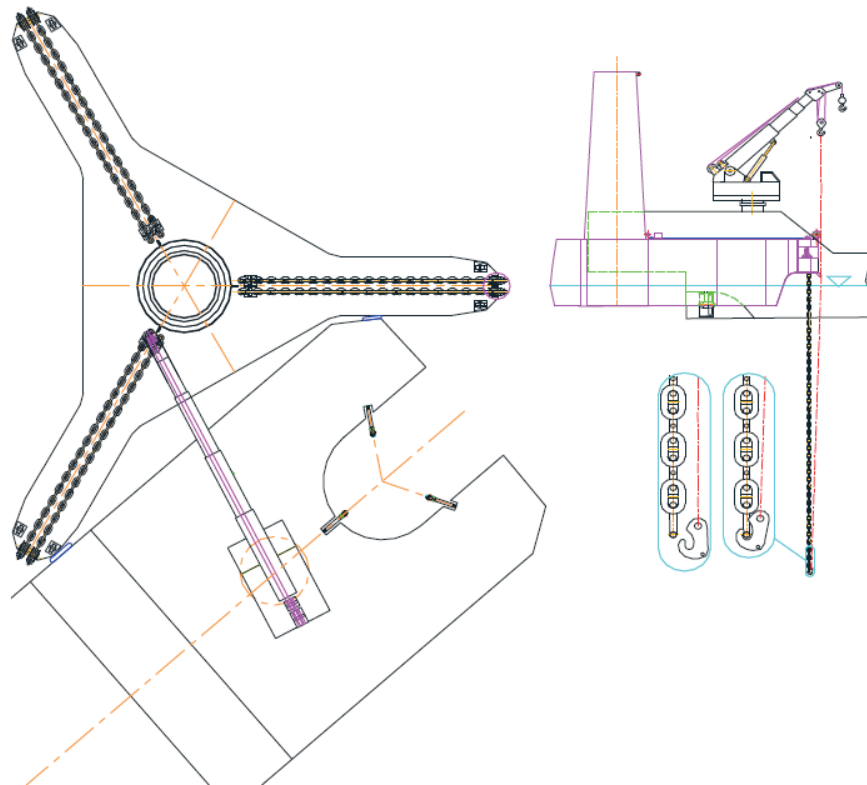

Fig. 2. Simplified top and side view of the specialist vessel position with respect to the platform in the beginning and final phase of chain lowering with the aid of the deck crane. The maximal required crane radius is  $R \approx 23$  m.

the rope winch, slowly lowers the chain, until it hangs with its end fastened in the chain pipe, thus unloading the rope, as shown in Fig. 2. In this situation, further hook lowering will cause its automatic loosening and disconnecting from the chain. Then the crane operator takes the rope with the hook from water and moves it towards the lug with the other chain on the same arm to lower it in the same way. The procedure of chain lowering from other arms is identical, but is to be preceded by vessel sailing to the next mooring position with respect to the arm.

### PREPARING FOR BALLASTING, BALLASTING, AND ANCHORING OF THE PLATFORM

After lowering all anchor chains, their fastening in the chain pipes are to be inspected visually, then the hull deck is to be cleared from plates and other redundant elements, and the control cords of mechanisms connecting anchor chains with piles, which were earlier fixed to the floating buoys, are to be now fixed to the cords on the platform, the other ends of which are in the control room in the upper part of the column. Further operations refer to direct preparation for platform ballasting. The type of these operations depends on the available devices and the adopted procedure. Below is presented the technology of platform ballasting and anchoring with the aid of the specialist vessel. In authors' opinion, this technology provides opportunities for maximal shortening of the operating time. It is assumed that this operation will

be able to be conducted at sea state below 3, which means the wind force  $3^{\circ}B$  and wave height of up to 0,5 m.

In the first stage after lowering the anchor chains, the platform servicemen are to be relocated via the crane to a bridge situated in the upper part of the platform column. This is the place where terminals and valves of the platform's ballast system are situated. Here, after passing elastic hoses from the ship and connecting the platform ballast system to that of the ship, the ballasting process is started, causing slow submergence of the platform hull to the depth of 9,5 m. Further platform submergence should be carried out at simultaneous stability control, as the platform loses stability when the hull is fully submerged. Then cameras and reflectors are installed underwater on the suction piles, along with control cords for the mechanisms fastening and releasing anchor chains. Before starting the final platform installation operation, the specialist vessel is to be connected with the platform column in such a way as to ensure platform stability after full submergence of its hull. To make it possible, the stern section of the vessel with a U-shaped symmetrical channel situated above the water line is equipped with three special devices symmetrically distributed with respect to the vessel's symmetry axis, in 120 degree steps, as shown in Figs. 3 and 4. Each device consists of the stand, situated on the upper deck of the stern section, with an arm leaned out over the channel, and a set of two main hydraulic servomotors and one auxiliary servomotor. The two main servomotors are connected together by a chain or cable rod, which allows the auxiliary servomotor to lean them out, as shown in Fig. 4. Special lugs with rollers having elastic raceways and equipped

with slide bearings are installed at the ends of the main servomotor piston rods. These servomotors are mounted in the vertical channel walls, and the lugs of each pair of them are connected together by a chain, which then goes through the chain wheel of the stand situated over the channel. On the other side of the stand it goes through the stopper and the auxiliary servomotor lug roller, to be finally fixed to the stand structure. For the time of voyage, the piston rod of the auxiliary servomotor is pulled inside the cylinder and the chain is locked in the stopper, which corresponds to the servomotor position: "lifted up".

Before this operation starts, elastic fenders are mounted on those vessel channel sides which are situated close to the platform structure. The main servomotors are lifted up, to increase the available channel width when the vessel nears the platform column. The vessel slowly moves back, keeping symmetrical position with respect to the platform hull arms in such a way that the symmetry plane of the stern section

channel continuously coincides with the column axis. The mounted fenders protect against contacts between the vessel and the platform and predetermine their relative positions. When the vessel stops in this preliminary position, which is close to the final correct position with respect to the platform column, the stoppers on the stands are released and the piston rods of the auxiliary servomotors are pulled out, this way setting the servomotors installed on the channel walls in the operating position. After checking the correctness of their positions, the chain stoppers on the stands are blocked and oil supply for the main servomotors is initiated, to ensure even and automatically controlled motion of their piston rods with rollers out of the cylinders. What is noteworthy, the option of individual manual control of their motion is also provided.

At this time, proper pressure contact of all rollers with the column and the accuracy of the column axis and platform position with respect to the elements on the seabed are to be re-checked and, if necessary, the platform position is to

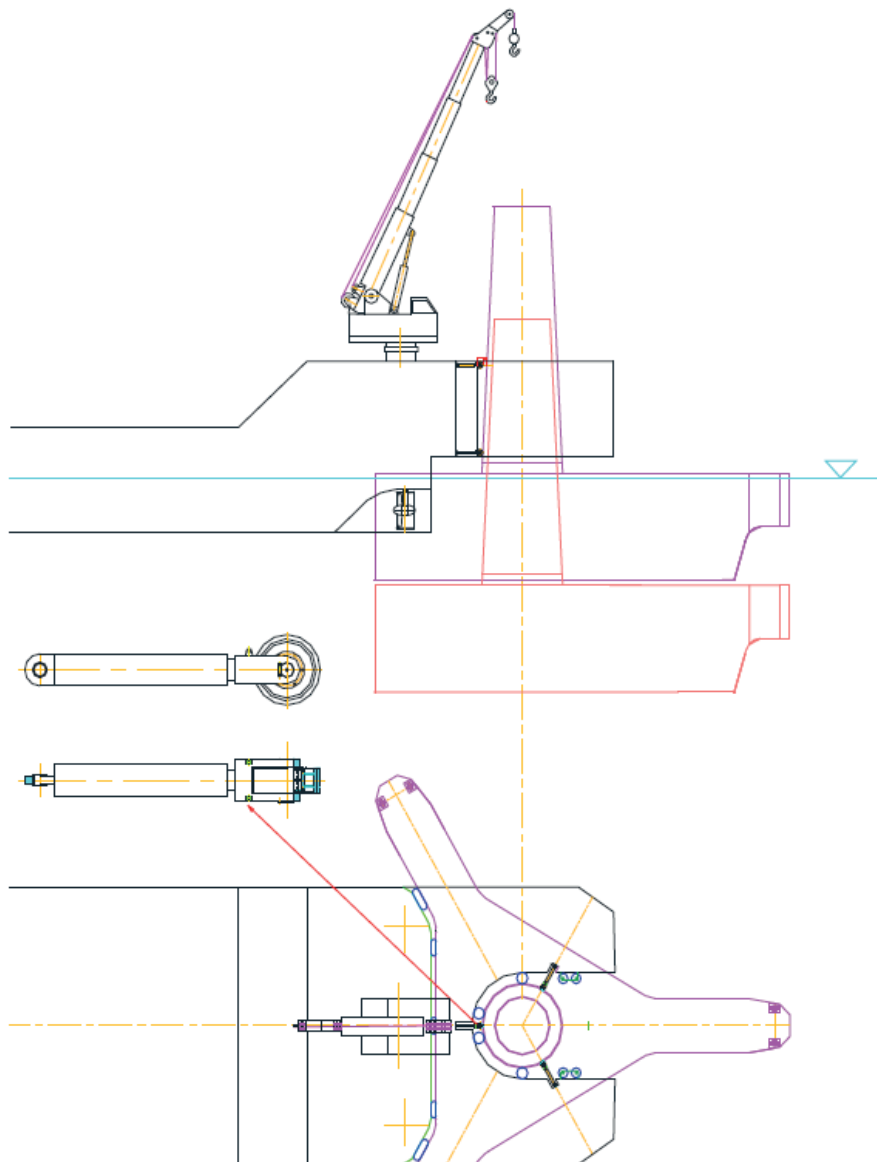

Fig. 3. Stern section of the specialist vessel during TLP platform installation

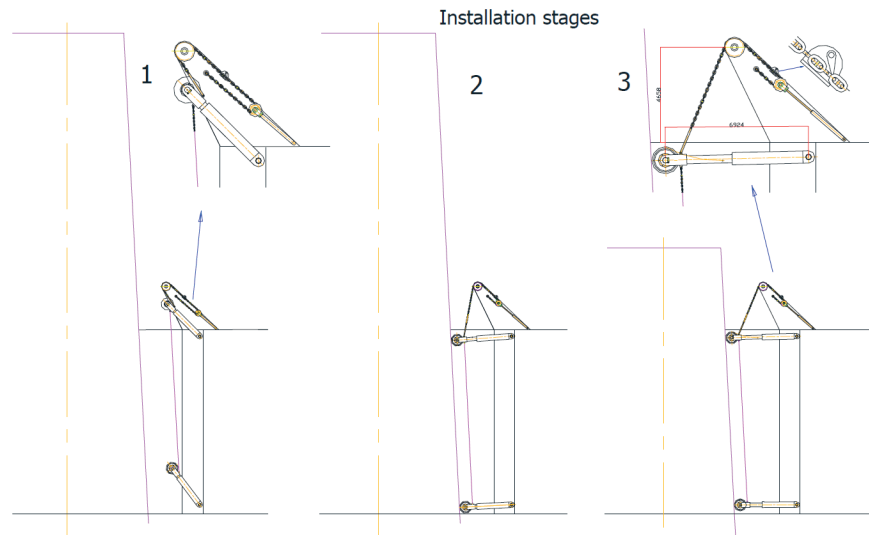

Fig. 4. Positions of servomotors positioning the platform with respect to the vessel during three basic platform installation stages: 1 – stage of bringing vessel's stern near the platform column – leading servomotor rollers lifted up to increase the save space around the column; 2 – stage of symmetrical setting of the vessel stern channel with respect to the platform column – leading servomotor rollers lowered to the operating position and pressed to the column; 3 – stage of platform ballasting and platform hull submergence – servomotors ensure controlled movement of the rollers and their pressure contact with the column; the diameter of the column in the planes of contact with servomotors decreases with the increasing submergence depth.

be corrected with the aid of the vessel propulsion system. Then the process of platform ballasting and submerging begins. During this process, continuous pressure contact of the servomotor rollers with the platform column is to be ensured, and the position of the column is to be continuously supervised, and accompanied with additional observation of motion of the last links of the anchor chains and their settlement in the seats of their fastening mechanisms, as shown in Figs. 5 and 6.

When slight clearance between two last chain links is observed, along with their deflection, the ballasting process is stopped. Releasing the control cords moves the pins in the mechanisms connecting the chain with the lugs on the suction piles.

After checking the blockages of all anchor chains, the platform should be slowly unballasted until all anchor chains become properly tight. The next step may be the start of removing the auxiliary equipment from the platform and transporting servicemen from the bridge on the column with the aid of the slewing deck crane. After completing these operations, the hydraulic supply system is switched on, to pull the main servomotor piston rods with rollers inside the cylinders. Once this process is completed, the chain stoppers on the stands over the channel are released and the hydraulic supply of auxiliary servomotors is switched on, to pull their piston rods inside the cylinders, thus setting the servomotors on the side walls of the channel to the “voyage” position, after

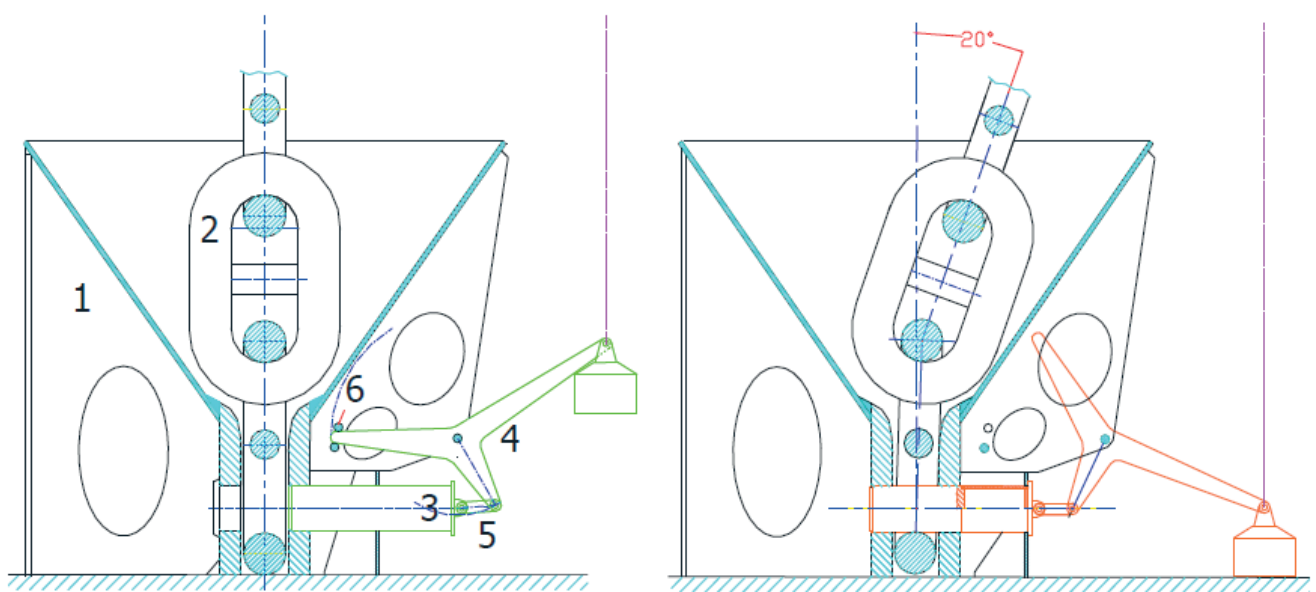

Fig. 5. Axial section through the mechanism connecting the anchor chain with the suction pile, just before and after chain blocking: 1 – pile's body, 2 – chain link, 3 – blocking pin, 4 – lever for chain blocking and release, 5 – connector between the lever arm and the pin moved by it, 6 – pins for optional lever position blocking

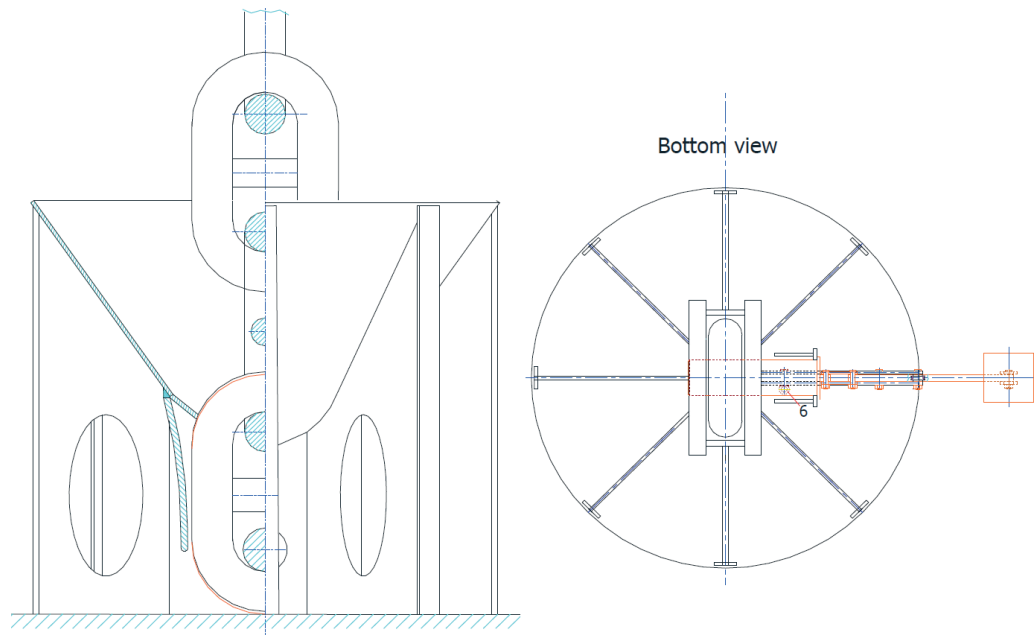

Fig. 6. Axial section through the mechanism fastening the anchor chain to the suction pile after blocking and tightening of anchor chains: half section (left) and bottom view (right)

which the chains are blocked in the stoppers. Then the vessel can start moving out of the area occupied by the platform.

## CONCLUSIONS

In authors' opinion, the presented technology concept of towing and installation of an offshore wind turbine supporting structure having the form of TPL-type platform is simpler and cheaper than other presently used technologies, at the same time fulfilling the safety requirements to the same extent. This assessment takes into account the number of objects to be installed in the Polish zone of the Baltic sea, in waters with depth exceeding 50 m, as well as the distance of the installed farms from the shipyard and sea conditions observed in these water regions. The use of well-known technologies making use of large self-lifting vessels with large cranes was assessed in this case as too expensive and not bringing substantial benefits with respect to both time consumption and safety of the operations to be performed. The authors believe that this article will find interest among institutions and companies involved in the here analysed problem matters, which will create space for meetings and discussions on substantive issues concerning operations of this type, all this resulting in wider and more objective evaluation of the proposed technology.

## ACKNOWLEDGMENT

This research was supported by The Polish National Centre for Research and Development (NCBR) under the project "WIND-TU-PLA" ERA-NET MARTEC II (Agreement No. MARTECII/1/2014)

## BIBLIOGRAPHY

1. Mikielwicz D., Wajs J., Ziółkowski P., Mikielwicz J.: Utilisation of waste heat from the power plant by use of the ORC aided with bleed steam and extra source of heat, *Energy*, 97, 11-19, 2016.
2. Kropiwnicki J., Kneba Z., Ziółkowski M.: Test for assessing the energy efficiency of vehicles with internal combustion engines. *International Journal of Automotive Technology*, Vol. 14, nr 3 (2013), s. 479-487.
3. Hirt Ł., Lampart P.: Complex multidisciplinary optimization of turbine blading systems// *ARCHIVES OF MECHANICS*. -Vol. 64, nr. 2 (2012), s.153-175.
4. Barthelmie R., Pryor S., Frandsen S., Hansen K., Schepers J., K. Rados K., Schlez W., Neubert A., Jensen L. and Neckelmann S.: Quantifying the Impact of Wind Turbine Wakes on Power Output at Offshore Wind Farms. *Journal of Atmospheric and Oceanic Technology* Vol. 27, 2010,
5. Ackermann T., Söder L.: Wind energy technology and current status: a review, *Renewable and Sustainable Energy Reviews*, 4 (2000), pp. 315-374
6. Markard J., Petersen R.: The offshore trend: structural changes in the wind power sector. *Energy Policy*, 37 (2009), pp. 3545-3556.
7. Musial W., Butterfield S., Ram B.: Energy from offshore wind. *Proc. offshore wind Conference Houston (2006)*, pp. 1888-1898.

8. Denis Matha: Model Development and Loads Analysis of an Offshore Wind Turbine on a Tension Leg Platform, with a Comparison to Other Floating Turbine Concepts. University of Colorado - Boulder Subcontract Report NREL/SR-500-45891, 2010.
9. Wandji W., Natarajan A., Dimitrov N.: Development and design of a semi-floater substructure for multi-megawatt wind turbines at 50+ m water depths. *Ocean Engineering*, Volume 125, 1 October 2016, Pages 226-237.
10. Dymarski C., Dymarski P., Żywicki J.: Design and strength calculations of the tripod support structure for offshore wind power plant. *Polish Maritime Research* 01/2015
11. Roddier D., Cermelli C., Aubault A., Alla Weinstein A.: WindFloat: a floating foundation for offshore wind turbines. *J Renew Sustain Energy*, 2 (2010), p. 033104
12. Adam F., Myland T., Schuldt B., Großmann J., Dahlhaus F.: Evaluation of internal force superposition on a TLP for wind turbines. *Renewable Energy*, Volume 71, November 2014, Pages 271-275
13. Butterfield S., Musial W., Jonkman J., Sclavounos P.: Engineering challenges for floating offshore wind turbines. *Proc. offshore wind conference Copenhagen (2005)*.
14. Bachynski E., Torgeir Moan T.: Design considerations for tension leg platform wind turbines. *Marine Structures*, Volume 29, Issue 1, December 2012, Pages 89-114.
15. Grelowska G., Kozaczka E., Kozaczka S., Szymczak W.: Sea bottom structure investigation by means of acoustic methods// *POLISH JOURNAL OF ENVIRONMENTAL STUDIES*. -Vol. 19, nr. No. 4A (2010), s.35-38.
16. Kozaczka E., Grelowska G., Szymczak W., Kozaczka S.: The Examination of the Upper Layers of the Seabed by the Means of the Acoustic Methods// *ACTA PHYSICA POLONICA A*. -Vol. 119, nr. No. 6A (2011), s.1091-1094.
17. Benassai G., Campanile A., Piscopo V., Scamardella A.: Ultimate and accidental limit state design for mooring systems of floating offshore wind turbines. *Ocean Engineering*, Volume 92, 1 December 2014, Pages 64-74.
18. Johanning L., Smith G.: Station keeping study for WEC devices including compliant chain, compliant hybrid and taut arrangement, *Proc. of the 27th International Conference on Offshore Mechanics and Arctic Engineering (OMAE)*, 2008
19. Fitzgerald J., Bergdahl L.: Considering mooring cables for offshore wave energy converters, *Proc. of the 7th European Wave and Tidal Energy Conference (EWTEC)*, 2007.
20. Masciola M., Robertson A., Jonkman J., Driscoll F.: Investigation of a FAST-OrcaFlex coupling module for integrating turbine and mooring dynamics of offshore floating wind turbines, *Proc. of the International Conference on Offshore Wind Energy and Ocean Energy (ICOWEOE)*, 2011.
21. Youhu Zhang Y., Husmann K., Andersen K., Tedesco G.: Ultimate bearing capacity of laterally loaded piles in clay – Some practical considerations. *Marine Structures*, Volume 50, November 2016, Pages 260-275.

#### **CONTACT WITH THE AUTHOR**

Czesław Dymarski  
Paweł Dymarski  
Jędrzej Żywicki

*e-mail: jedzywic@pg.gda.pl*

Gdańsk University of Technology  
Faculty of Ocean Engineering and Ship Technology  
11/12 Narutowicza St.  
80 - 233 Gdańsk  
**POLAND**