

A FLEXIBLE CONTROL STRATEGY FOR SHORE-TO-SHIP POWER SYSTEM IN TERMS OF GRID-CONNECTED AND OFF-GRID SWITCH

Zhendong Ji

Zhihong Zhao

School of Automation, Nanjing University of Science and Technology, Nanjing, Jiangsu, China

Jianhua Wang

School of Electrical Engineering, Southeast University, Nanjing, Jiangsu, China

Zhipeng Lv

China Electric Power Research Institute, Beijing, China

ABSTRACT

There are promising application prospects for applying the shore power technology to the ships in the port for the purpose of pollution prevention. However, the grid-connection of the shore power supply to the ship power grid leads to current surges, damages the ship power consumption equipment, and results in the instability of the ship power grid system, which will seriously affect the reliability of the operation of the ship power grid system. In order to address this problem, the mathematical model of virtual synchronous generator is introduced in this paper. Then, a control method for the flexible grid-connection of the shore power supply to the ship power grid based on the virtual synchronous generator is proposed. Next, the output characteristics of the shore power supply are optimized to match the characteristics of the ship generator, which contributes to the flexible grid-connection of the shore power supply to the ship power grid system. The effectiveness and the feasibility of this method are verified by simulation and experiments.

Keywords: Shore power supply; Ship power system; Virtual synchronous generator; Flexible control

INTRODUCTION

The shore-to-ship power system in the port refers to the shore power station that powers the ship, when the ship berths at the terminal and when the operation of all the ship diesel power stations is stopped. The voltage, frequency, and power of the shore power supply should be able to meet the necessary power demand of all power facilities after the ship is docked, thus reducing the emission of pollutants at the port, which symbolizes a revolutionary advancement in the field of port and ship power supply systems [1,2].

The implementation of the shore power technology on the ships in the port for the purpose of pollution prevention has been demonstrated by experts and scholars at home and abroad. The ship grid voltage includes both low voltage

and high voltage, the former referring to 440 V/400 V while the latter referring to 6.6kV/6kV [3]. In 2000, the first high-voltage shore power system was designed and installed at the ferry terminal of Gothenburg Port, Sweden. This technology has reduced the emission of pollutants by 94%-97% during the ship docking process [2]. Subsequently, the shore power technology was successively applied in the major ports in the European Union, such as the container terminals (Rotterdam Port in Netherlands and Antwerp Port in Belgium) and ferry terminals (Zeebrugge Port and Gothenburg Port). The grid-connection of the shore power supply has significantly improved the environmental quality.

The ship power grid system generally regulates the operations through the ship energy management system and achieves the power distribution and related operating

parameters. In order to adapt to the power distribution of the ship power grid, the power electronic device generally adopts the droop control strategy on the grid-connected side [4]. The droop control simulates the droop external characteristics of the generator by sampling, feeding back, and responding to the magnitude and frequency of the grid voltage. Although this control method has achieved excellent results in the inverter operation control and power distribution during the off-grid operation, it may bring significant transient current impact to grid-connected inverters [5]. In addition, in this simulation method based on the droop external characteristics of the generator the improper design of the droop coefficients may directly lead to the instability of the grid-connected inverter system [6]. The inverter performance based on this control method obviously cannot be compared with the conventional generator. Therefore, the grid-connection of the shore power supply to the ship power grid will impact the ship's power grid and damage the ship's power equipment. Besides, there will be difficulties in designing the system parameters, which easily leads to the system instability. Consequently, it is difficult to connect the shore power supply to the ship generator.

The synchronverter technology proposed by Professor Zhong Qingchang was used to connect the synchronous generator to the power electronic device so that the power electronic device can simulate the inertia and damping characteristics of the synchronous generator, which provides new solution to the grid-connected self-synchronization issue of the distributed power supply [7]. The mechanical and electrical equations of the synchronous generator were applied to the control algorithm of the grid-connected inverter. Then, the damping coefficients and the inertia time constant were adjusted so that the inverter was equipped with the inertia and damping characteristics of the synchronous generator while performing the power conversion, which can support the voltage and frequency stability of the power grid to a certain extent [8,9]. The key part of this technology is that it can simulate the inertia characteristics of a synchronous generator and induce a certain "inertia" into the distribution network. In the shore-to-ship power system based on power electronic inverters with the power system frequency and voltage modulation control algorithm, the shore power

supply was able to simulate the frequency and voltage control characteristics of the synchronous generator. The synchronous generator can match the output characteristics of shore power supply to the characteristics of the ship generator in order to flexibly connect the shore power supply to the ship power grid, increase the stability of the shore power supply, reduce the impact on the ship power grid, and protect the ship's power consumption equipment.

This paper presents a flexible grid-connected control strategy based on the virtual synchronous generator technology. Compared with the existing shore power supply technology, the proposed method is able to realize the functions of the traditional shore power supply and optimize the output characteristics of the shore power supply by approximating them to the characteristics of the ship generator, which is beneficial for the flexible grid-connection of the shore power supply to the ship power grid. Therefore, this study is of significant theoretical and engineering value.

TOPOLOGY AND THE PRINCIPLE OF SHORE POWER SUPPLY

The shore-to-ship power system is shown in Fig. 1. The 690 V/50 Hz AC power from the land-based power grid is rectified to DC power by 12-pulse rectifier to maintain the voltage stability of the DC sides and to avoid the harmonic pollution to the power grid. The outputs of the two sets of PWM inverters are connected in parallel and then to the 440 V/60 Hz ship power grid to form a power supply system, after the ship is docked.

Under the traditional shore power supply control method, the operational process of the shore power supply when the ship is docked is as follows: the ship diesel generator is stopped (the ship load is cut off) → the shore power supply is accessed → the shore power supply is started (the ship load is restored). The virtual synchronous generator control strategy enables the shore power supply system with the output droop, electrical, and mechanical characteristics to operate similarly to those of the diesel generator sets, ensuring the stable parallel operation and realizing the same scheduling

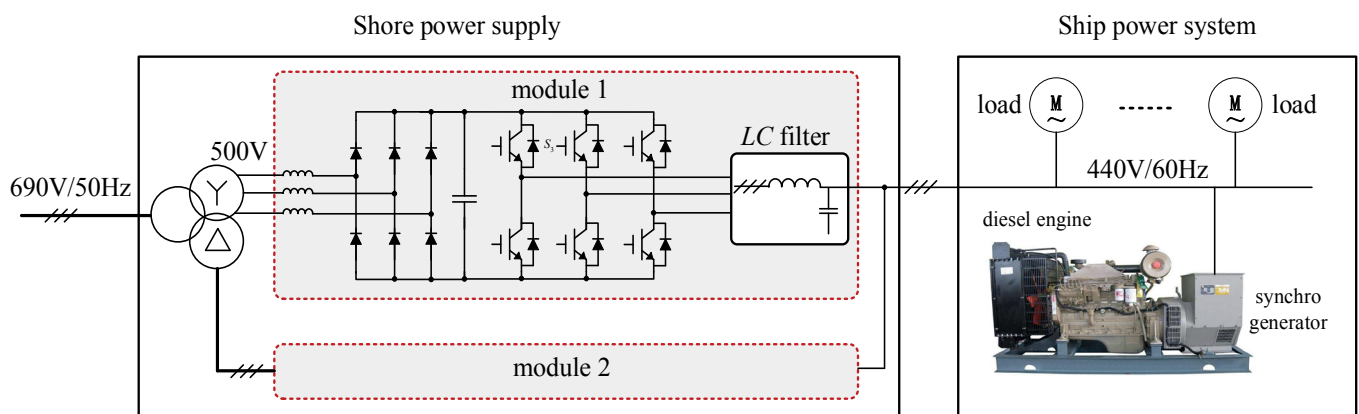

Fig. 1. Shore-to-ship power system

management of the ship's power management system (PMS) for the shore power supply and traditional diesel generator sets. The shore power supply operational process is as follows: the shore power supply is started → the shore power supply is connected to the ship power grid through the PMS scheduling control → the load is transferred → the ship diesel generators are separated from the power grid and shut down → the shore power supply provides uninterrupted power for the ship load independently. The access and withdrawal of the shore power supply do not require the cutoff of the ship load or affect the stability of the ship power system, which greatly simplifies the power supply process.

MATHEMATICAL MODEL OF SYNCHRONOUS INVERTER

MATHEMATICAL MODEL

As shown in Fig. 2, the synchronous impedance of the synchronous generator is equalized to the output filter inductance of the grid-connected inverter, while the voltage of the synchronous generator is equalized to the output voltage of the grid-connected inverter. Then, the grid-connected inverter is optimized to realize the frequency regulation and excitation control of the synchronous generator, thereby regulating the frequency and the voltage.

Based on the above analysis, the inverter can be controlled to simulate the operation of the synchronous generator with the relevant operation characteristics of the synchronous generator. Therefore, it is called the virtual synchronous generator. Firstly, the mechanical equation of the virtual synchronous generator is expressed as:

$$J \frac{d\omega}{dt} = T_m - T_e - T_d = T_m - T_e - D(\omega - \omega_0) \quad (1)$$

In Eq. (1):

J – the rotary inertia of the synchronous generator, unit: $\text{kg}\cdot\text{m}^2$;

H – the inertia time constant, unit: s;

ω – the angular speed of the synchronous generator;

ω_0 – the synchronous angular speed of the power grid;

T_m , T_e , and T_d – the mechanical, electromagnetic, and damping torques of the synchronous generator, unit: $\text{N}\cdot\text{m}$;

D – the damping coefficient, unit: $\text{N}\cdot\text{m}\cdot\text{s}/\text{rad}$.

Specifically, the electromagnetic torque T_e of the synchronous generator can be obtained from the potential e_{abc} and the output current i_{abc} of the virtual synchronous generator, which implies that:

$$T_e = P/\omega = (e_a i_a + e_b i_b + e_c i_c) / \omega \quad (2)$$

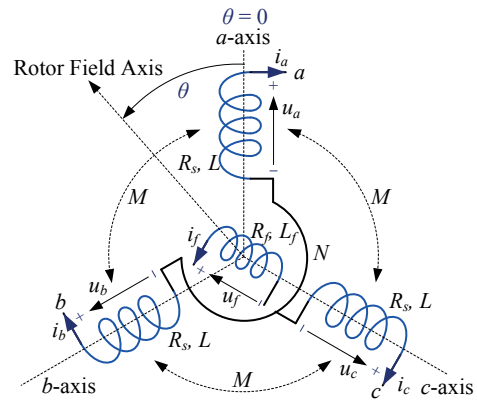

(a) Physical model of the synchronous generator

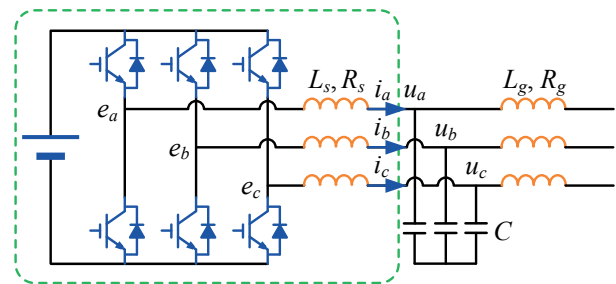

(b) Physical model of the grid-connected inverter

Fig. 2. Physical model of the grid-connected inverter to simulate the synchronous generator

In the control of the virtual synchronous generator, it is worth noting that the inertia time constant H provides the grid-connected inverter with the inertia characteristics similar to those of the synchronous generator, which supports the frequency stability to a certain extent. Besides, the damping coefficient D provides the grid-connected inverter with the damping characteristics similar to those of the synchronous generator, which effectively damps the fluctuation of the system output power and enables the random power supply to be smoothly connected to the grid. The above two parameters play a very important role in improving the operating performance of the grid-connected inverter [63-67].

Secondly, the electromagnetic equation of the virtual synchronous generator is obtained from Fig. 1 and is expressed as

$$L \frac{di_{abc}}{dt} = e_{abc} - u_{abc} - Ri_{abc} \quad (3)$$

In Eq. (3):

L – the synchronous reactance of the synchronous generator;

R – the synchronous resistance of the synchronous generator;

u_{abc} – the terminal voltage of the synchronous generator.

The synchronous reactance of the synchronous generator is equalized to the filter inductance of the grid-connected

inverter, while the transient voltage of the synchronous generator is equalized to the output voltage of the three-phase half-bridge inverter. It is worth noting that L and R in Eq. (3) may be different from the filter inductance of the actual grid-connected inverter. On the one hand, an increase in R can increase the system damping but lead to the control error in the system voltage and reactive power. On the other hand, an increase in L can also increase the system damping but lead to the static control error in the system, making the system output voltage and active power unable to track the given values.

(1) Electrical model

The synchronous generator parameters used in this paper are: the self-inductance and the mutual inductance of stator winding, where p pole pairs are respectively L and M ($M > 0$), as shown in Fig. 2(a).

L_f is the self-inductance of the field winding. The mutual inductance between the three-phase stator and the field core changes with the rotation angle θ , which is expressed as:

$$\begin{cases} M_{af} = M_f \cos(\theta) \\ M_{bf} = M_f \cos(\theta - 2\pi/3) \\ M_{cf} = M_f \cos(\theta - 4\pi/3) \end{cases} \quad (4)$$

The flux chain of the winding is expressed as:

$$\begin{cases} \phi_a = Li_a - Mi_b - Mi_c + M_{af}i_f \\ \phi_b = -Mi_a + Li_b - Mi_c + M_{bf}i_f \\ \phi_c = -Mi_a - Mi_b + Li_c + M_{cf}i_f \\ \phi_f = M_{af}i_a + M_{bf}i_b + M_{cf}i_c + L_fi_f \end{cases} \quad (5)$$

As $i_a + i_b + i_c = 0$, the stator flux can be expressed as:

$$\begin{cases} \phi = (L + M)i + M_f i_f \cos \theta \\ \phi_f = L_f i_f + M_f \langle i, \cos \theta \rangle \end{cases} \quad (6)$$

In Eq. (6):

$$\phi = \begin{bmatrix} \phi_a \\ \phi_b \\ \phi_c \end{bmatrix}, i = \begin{bmatrix} i_a \\ i_b \\ i_c \end{bmatrix};$$

$$\cos \theta = \begin{bmatrix} \cos \theta \\ \cos(\theta - 2\pi/3) \\ \cos(\theta + 2\pi/3) \end{bmatrix};$$

$$\widetilde{\sin \theta} = \begin{bmatrix} \sin \theta \\ \sin(\theta - 2\pi/3) \\ \sin(\theta + 2\pi/3) \end{bmatrix}.$$

The second term in Eq. (6) is constant when the three-phase current is sinusoidal and balanced. Assuming that the stator winding is R_s and the phase voltage is $v = [v_a, v_b, v_c]^T$, the following equation can be obtained:

$$v = -R_s i - \frac{d\phi}{dt} = -R_s i - L_s \frac{di}{dt} + e \quad (7)$$

where e is the magnetic field voltage generated by the rotor rotation and is expressed as:

$$e = \dot{\theta} M_f i_f \widetilde{\sin \theta} - M_f \frac{di_f}{dt} \widetilde{\cos \theta} \quad (8)$$

(2) Mechanical model

The mechanical model of the synchronous generator is expressed as:

$$J \ddot{\theta} = T_m - T_e + D_p \dot{\theta} \quad (9)$$

In Eq. (9):

J - the rotary inertia of the synchronously rotating mechanical part in the rotor, unit: $\text{kg} \cdot \text{m}^2$;

T_m - the mechanical torque, unit: $\text{N} \cdot \text{m}$;

T_e - the electromagnetic torque, unit: $\text{N} \cdot \text{m}$;

D_p - the damping coefficient.

T_e^p - can be calculated from the total energy E of the generator, which is the sum of the magnetic energy and the kinetic energy, and is expressed as:

$$E = \frac{\langle i, L_a i \rangle}{2} + M_f i_f \langle i, \widetilde{\cos \theta} \rangle + \frac{L_f i_f^2}{2} + \frac{J \dot{\theta}^2}{2} \quad (10)$$

As the rotor mechanical angle θ_m satisfies $\theta = p\theta_m$, the following equation can be obtained:

$$T_e = p M_f i_f \langle i, \widetilde{\sin \theta} \rangle \quad (11)$$

The mechanical part of the virtual synchronous generator is modelled as above. The mechanical model and the electrical model of the virtual synchronous generator will be used in the design of the control algorithm [6].

ACTIVE POWER REGULATION

The active power regulation of traditional synchronous generators is achieved through the adjustment of mechanical torque, while the frequency regulation is achieved through adjustment of the frequency regulator. Compared with traditional synchronous generators in the virtual synchronous generator control technology, the virtual machine torque T_m can be regulated by adjusting the reference active power of the inverter. The frequency deviation feedback command ΔT and the reference mechanical torque T_0 constitute the virtual mechanical torque T_m , where $T_0 = P_{ref}/\omega$ and P_{ref} is the active power value of the grid-connected inverter controlled by the virtual synchronous generator. Therefore, the frequency is regulated by the virtual automatic frequency regulator. When the virtual automatic frequency regulator is adopted as an element of proportionality, the frequency deviation feedback command ΔT is expressed as:

$$\Delta T = k_f(f - f_0) \quad (12)$$

Where f is the frequency of the terminal voltage in the virtual synchronous generator, f_0 is the reference frequency of the power grid, and k_f is the frequency regulation coefficient.

It can be seen that contrary to the previous PQ control strategies of grid-connected inverters, the active power regulation of the virtual synchronous generator technology can track the active power and perform corresponding active power regulation in response to the frequency deviation of the power grid, thereby simulating the frequency regulation performance of the synchronous generator and effectively resolving the response of the grid-connected inverter based on power electronics technology to the frequency faults of the power grid.

REACTIVE POWER REGULATION

The traditional synchronous generator regulates the terminal voltage and reactive power through excitation regulation. The regulation of the terminal voltage and reactive power of the virtual synchronous generator can be achieved by regulating the virtual electromotive force [10-12].

The virtual electromotive force generator command of the virtual synchronous generator consists of three components. The first component is the empty-load electromotive force E_0 of the virtual synchronous generator. The second component is ΔE_Q , corresponding to the reactive power regulation, which is specifically expressed as:

$$\Delta E_Q = k_q(Q_{ref} - Q) \quad (13)$$

Where k_q is the reactive power regulation coefficient, Q_{ref} is the reference reactive power of the grid-connected inverter, and Q is the instantaneous reactive power output of the virtual synchronous generator expressed as:

$$Q = \frac{(u_a - u_b)i_c + (u_b - u_c)i_a + (u_c - u_a)i_b}{\sqrt{3}} \quad (14)$$

It is equivalent to the automatic voltage regulator or excitation regulator of the synchronous generator.

The third component is ΔE_U , corresponding to the terminal voltage regulation of the virtual synchronous generator, and is specifically expressed as:

$$\Delta E_U = \left(k_v + \frac{k_i}{s} \right) (U_{ref} - U) \quad (15)$$

Where k_v is the voltage regulation coefficient, k_i is the integral coefficient, U_{ref} is the effective terminal voltage of the virtual synchronous generator, and U is the actual measured terminal voltage of the virtual synchronous generator.

It can be seen that compared with the traditional PQ control strategies of grid-connected inverters, the reactive power regulation of the virtual synchronous generator technology can track the reactive power and contribute to the voltage regulation of the distribution network. It regulates the reactive power according to the difference between the reference output voltage of the grid-connected inverter and the actual measured voltage, adjusting the reactive power to achieve the voltage stability of power grid.

DEFINITION OF THE INERTIA CONSTANT

When the input mechanical power and the output electromagnetic power are not balanced, the synchronous generator will accelerate or decelerate, accompanied by swings in its output power, power angle, and other variables. The swing equation of the synchronous generator can be expressed as:

$$\frac{d}{dt} \left(\frac{1}{2} J \omega^2 \right) = P_m - P \quad (16)$$

Where J and ω are respectively the rotary inertia and angular velocity of the synchronous generator, P_m and P are respectively the mechanical power and the electromagnetic power of the synchronous generator.

$$\frac{d}{dt} \left(\frac{1}{2} J \omega^2 \right) = J \omega \frac{d\omega}{dt} \approx J \omega_0 \frac{d\omega}{dt} \quad (17)$$

Where ω_0 is the rated angular velocity of the synchronous generator. In addition, it should be pointed out that during the rotation of the generator's rotor, there is always mechanical friction damping, and the friction coefficient is denoted as D .

If $\omega_r = \omega/\omega_0 - 1$ is defined as the per unit of angular velocity deviation, we can further obtain the following expression:

$$J\omega_0 \frac{d\omega_r}{dt} = T_m - T_e - D\omega_r \quad (18)$$

In order to facilitate the analysis of inertial magnitudes of generators with different capacities, the inertia of the synchronous generator is described by the inertial time constant H , which is defined as follows:

$$H = \frac{J\omega^2}{2S_b} \quad (19)$$

Where S_b is the rated capacity of the synchronous generator to avoid the difficulty of comparing the inertial magnitudes of the synchronous generators with different capacities. In the meantime, H is of special physical significance, and its unit is second. Its numerical magnitude indicates the time required for the synchronous generator to start from the zero output power to the rated power.

SHORE POWER SUPPLY CONTROL STRATEGY BASED ON THE SYNCHRONOUS GENERATOR

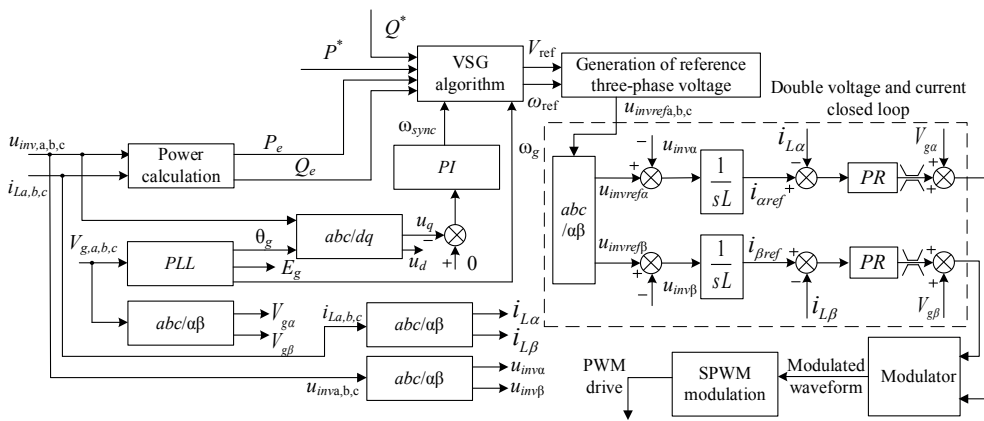

Fig. 3. Flexible grid-connection control strategy of the shore power supply based on the virtual synchronous generator technology

Fig. 3 shows the flexible grid-connection control strategy of the shore power supply based on the virtual synchronous generator proposed in this paper, including the outer power control loop and the inner voltage and current control loop. The outer power control loop includes the following steps: measurement of the three-phase voltage and current on the inverter output side, calculation of the active power and reactive power according to the instantaneous power theory, calculation and regulation through the active power-frequency

equation, reactive power-frequency equation, torque inertia equation, the electromagnetic transient equation of the synchronous generator to obtain the output voltage amplitude and phase angle, and modulation through the double voltage and current loop. The inner voltage and current control loop includes the following steps: synthesis of the amplitude and the phase angle command of the voltage derived from the outer power control loop into the three-phase reference voltage, its conversion into the two-phase stationary coordinate system through the three-phase stationary coordinate system, comparison of the reference value of the outer input voltage control loop with the measured voltage, its regulation by PR, and finally its comparison with the grid voltage converted to the two-phase stationary coordinate system. Then, the output of the modulation wave signal and the PWM switching signal to control the inverter output voltage signal are produced.

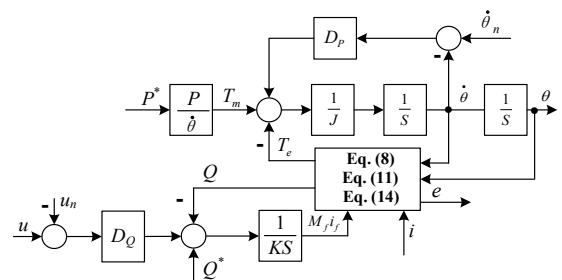

Fig. 4. Control strategy of virtual synchronous generator

The electrical model and the mechanical model of the synchronous generator described above are applied to the inverter control in order to obtain the virtual synchronous generator control strategy as described in Fig. 4. The control input signals P^* and Q^* cause the controller to generate the signals T_m and Mj/f to maintain the system's stability and produce the desired active and reactive power. The terminal voltage u can be obtained from the inverter output as shown in Fig. 2(b).

The controller based on the virtual synchronous generator can produce the average output of e_a , e_b and e_c in one switching cycle, and then the same PWM technology is used to complete the driving pulse generation of the inversion part of the shore power supply.

(1) Frequency droop and active power regulation

The rotor velocity of synchronous generators is constrained by the prime mover, while the damping coefficient D_p is related to the mechanical friction factor. Synchronous generators can reduce the frequency according to the actual active power output, thus realizing even load sharing [13-16]. When the demand for active power increases, the rotation

velocity of the prime mover in the generator set will decrease to a certain extent. The frequency regulator increases the output mechanical power. This process can be realized by subtracting the actual angular velocity from the rated angular velocity and by adjusting the damping control module. As shown in Fig. 3, the damping coefficient D_p is expressed as the frequency droop coefficient in the actual control process, and it is defined as the ratio of the required torque change to the angular velocity change, which is expressed as:

$$D_p = \frac{\Delta T}{\Delta \dot{\theta}} = \frac{\Delta T}{T_{mn}} \frac{\dot{\theta}_n}{\Delta \dot{\theta}} \frac{T_{mn}}{\dot{\theta}_n} \quad (20)$$

Where T_{mn} is the rated mechanical torque. As there is no delay in the frequency loop, the frequency loop time constant can be made smaller than that of the actual synchronous generator. The quotient of the reference active power P^* and the rated mechanical angular velocity is the mechanical torque T_m . As shown in the upper part of Fig. 3, this control scheme achieves the closed-loop control of active power. Due to the frequency droop mechanism, the loaded active power is automatically shared by the same bus.

(2) Voltage droop and reactive power regulation

The reactive power Q can be regulated by a similar control method. The voltage droop coefficient is defined as the ratio of the reactive power change ΔQ to the voltage change Δv . The following expression is obtained:

$$D_q = \frac{\Delta Q}{\Delta v} = \frac{\Delta Q}{Q_n} \frac{v_n}{\Delta v} \frac{Q_n}{v_n} \quad (21)$$

Where Q_n is the rated reactive power and u_n is the rated terminal voltage. The reactive power feedback loop is shown in the lower part of Fig. 3. Before being superimposed by the difference of real-time reactive power and the set value of the reactive power, the terminal voltage u is subtracted from the rated voltage u_n . Then, the signal M_{ij} integrator is produced from the calculation of the D_q link and the integrator with a gain of $1/K$.

SIMULATION ANALYSIS AND EXPERIMENTAL VERIFICATION

SIMULATION ANALYSIS

For the above analysis, a corresponding PSCAD simulation model was built. The voltage on the DC side was 800 V, the three-phase output line voltage was 380 V, the frequency was 50 Hz, and the switching frequency was 20 kHz. There was no load during 0~1 s. Afterwards, the load was increased to 60 kW for 1~4 s. During 4~5 s, the load was reduced to 40 kW. After 5 s, the load was restored to 60 kW. The simulation

waveforms are shown in Fig. 5(a)-(d) below. It can be seen that under the control strategy based on the virtual synchronous generator, the shore power supply can automatically regulate the power according to the load fluctuations, while the frequency and the potential can be automatically regulated according to the power, which demonstrates the nature of the synchronous generator, including certain inertia and damping characteristics. Therefore, it can be utilized in the frequency and voltage regulation of the ship power grid system.

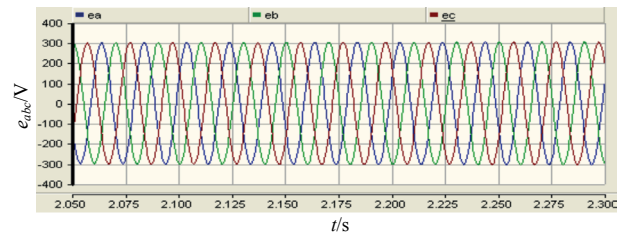

(a) Output waveform figure

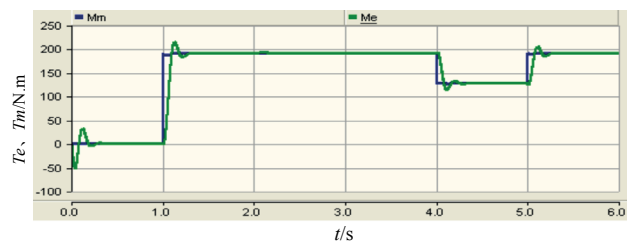

(b) Torque waveform figure

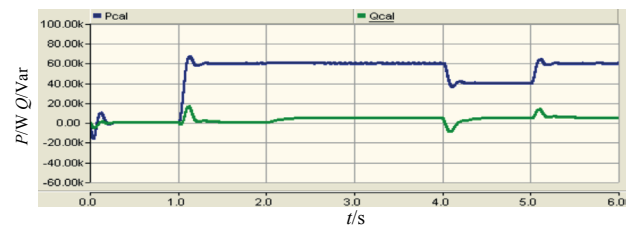

(c) Power waveform figure

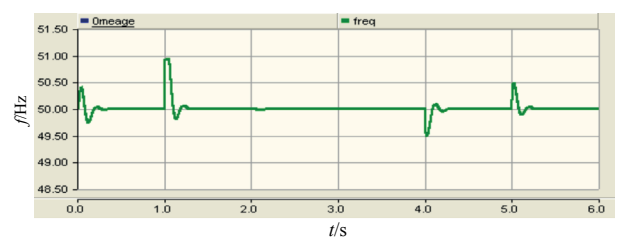

(d) Output frequency waveform

Figure 5. Simulation waveforms of shore power supply

EXPERIMENTAL VERIFICATION

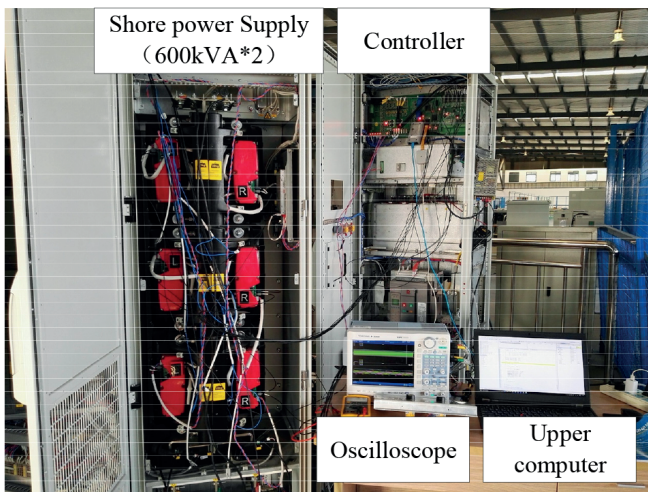
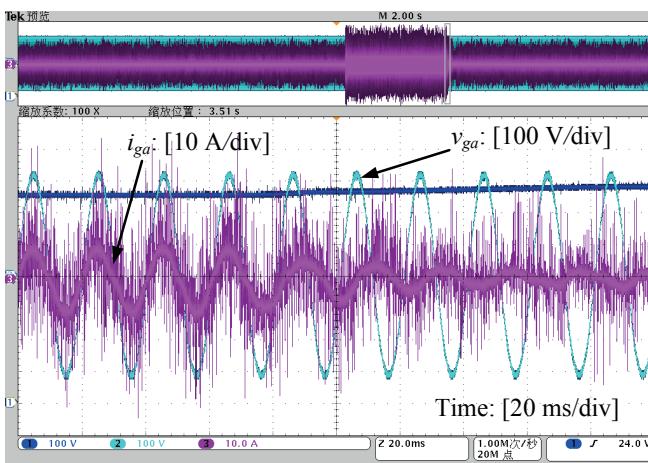

Fig. 6. 600 kVA*2 shore power supply device

Fig. 6 shows the 600 kVA*2 shore power supply device. The specific topology is shown in Fig. 1. DSP + FPGA framework is used in the controller. DSP is used to implement the control algorithm, and FPGA is used to implement logical judgment, fault handling, communication, and other functions.

Under the control method proposed in this paper, the shore power supply has the ability to automatically participate in the regulation of the ship power grid, which means that it can automatically regulate its output active power and reactive power according to the change in the grid voltage amplitude and frequency. Regarding the control parameters, the following cases are designed: the frequency of the ship grid voltage changes by 1 Hz and the active power changes by 5 kW; the amplitude of the ship grid voltage changes by 10% and the reactive power changes by 12 kVar.



(a) The frequency of the ship grid voltage reduces (increases) by 1 Hz, and the active power increases (reduces) by 5 kW

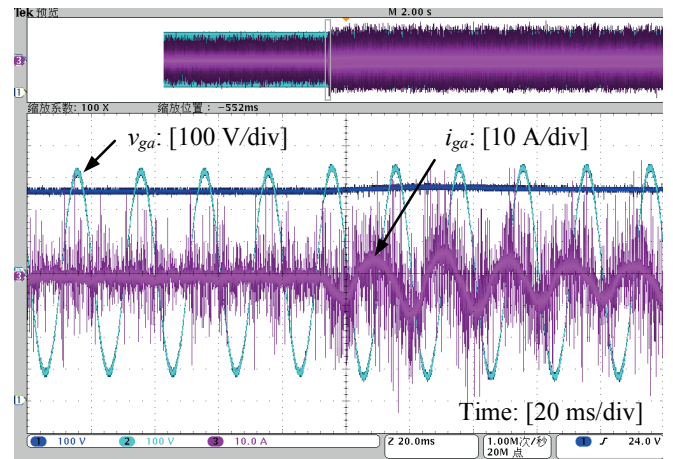

(b) The amplitude of the ship grid voltage increases (reduces) by 5%, and the reactive power reduces (increases) by 6 kVar

Fig. 7. Experimental waveforms when the shore power supply participates in the power regulation of the ship power grid

Fig. 7 shows the experimental waveforms of the following cases: (a) the frequency of the ship grid voltage reduces by 1 Hz and the active power increases by 5 kW; the frequency of the ship grid voltage increases by 1 Hz and the active power reduces by 5 kW; (b) the amplitude of the ship grid voltage decreases by 5% and the reactive power increases by 6 kVar; the amplitude of the ship grid voltage increases by 5% and the reactive power reduces by 6 kVar. It can be seen from Fig. 7 that the solid state module can automatically regulate its output active power and reactive power according to the frequency and amplitude of the grid voltage, and the power change is the same as the reference value, which meets the indicator requirement. In addition, it can be clearly seen that after the frequency or voltage jumps, it takes a certain period of time for the output active power or reactive power to stabilize, which confirms the presence of certain inertia after the integration of the virtual generator control.

Fig. 8 shows the dynamic waveforms when the shore power supply is connected to the ship power grid. At the time t_1 , the diesel generators are connected to the ship power grid, and the load is completely supplied by the diesel generators. At the time t_2 , the shore power supply is connected, and it supplies part of the load under the coordination of the PMS. Then, the output current of the diesel generators i_{dga} gradually decreases, while the output current of the shore power supply i_{ga} increases. At the time t_3 , the load is completely transferred to the shore power supply, and the diesel generators produce zero output current and can be shut down. During the entire process, the ship power grid receives uninterrupted power supply, and the flexible grid connection of the shore power supply is realized, which effectively protects the ship power grid and its power consumption equipment.

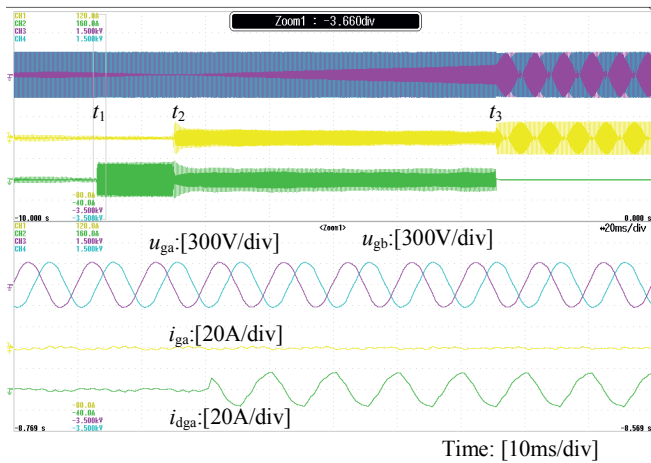

Fig. 8. Dynamic waveforms when the shore power supply is connected to ship power grid

CONCLUSION

In this paper, based on the study of the topology and the working principle of the shore power supply, a control method for the flexible grid-connection of the shore power supply to the ship power grid is proposed. The method is based on the virtual synchronous generator technology and addresses the problems of traditional control methods of the grid-connection of the shore power supply to the ship power grid: current surges, damages to the ship power consumption equipment, and the resulting instability of the ship power grid system. The proposed method can not only implement the functions of the traditional shore power supply system, but also optimize the output characteristics of the shore power supply and make them closer to those of the ship generator sets, which contributes to the flexible grid-connection of the shore power supply to the ship power grid. In order to verify the feasibility and effectiveness of the control method proposed in this paper, respective simulations and experiments are carried out. The results show that this method presents better steady-state and transient performance and has great value for its application in the shore-to-ship power system.

ACKNOWLEDGEMENTS

This project is partially supported by Natural Science Foundation of Jiangsu Province (BK20170841).

BIBLIOGRAPHY

1. K. L. Peterson, P. Chavdarian, M. Islam and C. Cayan.: *Tackling ship pollution from the shore*, IEEE Industry Applications Magazine, vol. 15, no. 1, pp. 56-60, 2009.

2. D. Paul and V. Haddadian.: *Transient Overvoltage Protection of Shore-to-Ship Power Supply System*, IEEE Transactions on Industry Applications, vol. 47, no. 3, pp. 1193-1200, 2011..
3. M. H. Chou, C. L. Su, Y. C. Lee, H. M. Chin, G. Parise and P. Chavdarian.: *Voltage-Drop Calculations and Power Cable Designs for Harbor Electrical Distribution Systems With High Voltage Shore Connection*, IEEE Transactions on Industry Applications, vol. 53, no. 3, pp. 1807-1814, 2017.
4. M. Yu, W. Huang, N. Tai, X. Zheng, Z. Ma and Y. Wang.: *Advanced microgrid and its multi-objective regulation strategy for shore supply*, The Journal of Engineering, vol. 2017, no. 13, pp. 1590-1594, 2017.
5. EPRI.: *P124 Advanced distribution automation-program overview*, 2008.
6. J. M. Guerrero et al.: *Distributed Generation: Toward a New Energy Paradigm*, IEEE Industrial Electronics Magazine, Vol. 4, no. 1, pp. 52-64, 2010.
7. Zhong Q C, Hornik T.: *Control of power inverters in renewable energy and smart grid integration*, John Wiley & Sons, 2012.
8. Yong Chen, Hesse R, Turschner D, et al.: *Improving the Grid Power Quality Using Virtual Synchronous Machines*. *Power Engineering, Energy and Electrical Drives (POWERENG)*, pp.11-13, 2011.
9. Fang Gao, Iravani M R.: *A Control Strategy for a Distributed Generation Unit in Grid-Connected and Autonomous Modes of Operation*. IEEE Transactions on Power Delivery, Vol. 23, no. 4, pp. 850-859, 2008.
10. T. Younis, M. Ismeil, M. Orabi, E. K. Hussain.: *A single-phase self-synchronized synchronverter with bounded droop characteristics*, 2018 IEEE Applied Power Electronics Conference and Exposition (APEC), pp. 1624-1629, 2018.
11. H. Li et al.: *Single-phase synchronverter dynamic optimization and parameters design*, 43rd Annual Conference of the IEEE Industrial Electronics Society, pp. 7866-7871, 2017.
12. M. Oñate, J. Posada, J. López, J. Quintero and M. Aredes.: *Control of a back-to-back converter as a power transfer system using synchronverter approach*, IET Generation, Transmission & Distribution, vol. 12, no. 9, pp. 1998-2005, 2018.
13. D. Grider, M. Das, A. Agarwal, J. Palmour, S. Leslie, J. Ostrop, R. Raju, M. Schutten, and A. Hefner.: *10kV/120A SiC DMOSFET half-bridge power modules for 1 MVA solid state power substation*, Proc. IEEE Electr. Ship Tech. Symp, pp. 131 - 134, 2011.

14. K. Hatua, S. Dutta, A. Tripathi, S. Baek, G. Karimi, and S. Bhattacharya.: *Transformerless intelligent power substation design with 15 kV SiCIGBT for grid interconnection*, Proc. IEEE ECCE, pp. 4225–4232, 2011.
15. H. F. Fan and H. Li.: *High frequency transformer isolated bidirectional DC-DC converter modules with high efficiency over wide load range for 20 kVA solid state transformer*, IEEE Trans. Power Electronics, vol. 26, no. 12, pp. 3599–3608, 2011.
16. H. S. Qin and J. W. Kimball.: *AC-AC dual active bridge converter for solid state transformer*, in Proc. IEEE ECCE, pp. 3039–3044, 2009.

CONTACT WITH THE AUTHORS

Zhendong Ji, Ph.D.

e-mail: zhendong_ji@126.com

tel.: +86 18936044964

School of Automation

Nanjing University of Science and Technology

Nanjing Jiangsu 210094

CHINA