

SELECTION OF MAIN ENGINES FOR HOPPER SUCTION DREDGERS WITH THE USE OF PROBABILITY MODELS

Damian Bocheński

Gdańsk University of Technology, Poland

ABSTRACT

This paper presents a new original method of selection of main engines for hopper suction dredgers with regard to probabilistic models. It was proposed to use the normal distribution to describe the operational loads of the main receivers. The principles for determination of parameters of load distribution and design power of the main engines were formulated. Lastly, the principles of selection of the size and number of main engines has been proposed.

Keywords: hoppers suction dredgers, main engines, design

INTRODUCTION

The selection of main engines for hopper suction dredgers, due to the large number of main types of energy receivers and the significant variability of energy demand in particular the operating states, is one of the most difficult tasks in the design of marine power plants.

On the hopper suction dredgers one can find four main types of energy receivers, which are [9]:

- receivers for self-propulsion, dredging and maneuvering (propulsors and bow thrusters),
- receivers connected with the break-up, grounding and transport of the soil (dredge pumps and jet pumps).

On the hopper suction dredges, very often the drive of several major energy consumers is used by one main engine (centralized drive of main power receivers). In many cases, the main engine may have a nominal power less than the combined power of the main power receivers (this is the result of variability of the load of this type of main receivers during the work involved in dredging works).

Design of dredger power systems requires the use of appropriate pre-design methods when deciding on the size and number of main and auxiliary engines.

In currently used shipbuilding engine design methods [10, 11, 12, 13, 14, 15, 16, 17] and in the recommendations of marine engine manufacturers [18, 19, 20, 21, 22], deterministic methods are used for the selection of main engines. This is based on the assumptions used for calculations, established working conditions and related equipment parameters corresponding to the most unfavorable energy situation.

According to the author, significant advances in dredging machine initialization methods and in solving a number of exploitation problems are due to the use of probabilistic models containing random variables or random functions. Probabilistic models will better describe the complex and variable realities of dredger operation, which are strongly influenced by casual factors rather than deterministic models.

On the basis of the author's research, published in [3, 4, 6, 9], it can be assumed that to describe the operating load power of the main power dredgers receivers (or groups

of auxiliary energy receivers), which are random variables one may use normal or close to normal distribution. Additionally, there is the possibility of assuming independence between the simultaneous power loads of the main power receivers.

The justification for assuming that load distributions of these receivers (or groups of receivers) can be described by normal distribution (or close to normal) is the fact that their load affects many randomly varying volumes. For example, they may be external conditions (winds, currents, waves, etc.), dredging conditions (bottom shape, length of pipelines, type of dredging). They significantly affect the load of the main receivers. Power loads are dependent on the demand generated by numerous (about several hundred) auxiliary energy receivers operating independently.

OPERATIONAL LOADS OF MAIN POWER RECEIVERS

The main energy receivers of the hopper suction dredgers are characterized by different power loads in the individual jobs of the “dredging” work [3,4,5,9]. Therefore, the confirmation of the assumption concerning the normality of load distributions of the main energy receivers of dredgers was related to the construction of models of their exploitation loads, taking into account the components of state of “dredging works” [9].

As regards dredger suction dredgers, “dredging works” are divided into the following works [9]:

In regards to hopper suction dredgers, “dredging works” are divided into the following works [9]:

- loading (the dredger moves at 2-3 knots with lowered suction pipes, loading of the hopper with dredge pumps, the jet pumps help to break the soil to the bottom, positioning the dredger using the bow thrusters);
- sailing between places of loading and unloading (dredger moving at the speed of several knots, distance from several to over 100NM);
- unloading of the hopper (unloading by pumping the excavated material with the dredge pumps, jet pumps diluting the ground in the hopper, dynamic positioning the dredger with the bow thrusters).

The results of in-service research have allowed us to develop methods of forecasting operational loads of main dredger energy receivers [7, 8, 9]. These studies have identified the relationship between the load distribution parameters of the main dredger receivers (N_{MR}^{us} , σ_{MR}) and their nominal useful power ($N_{MR}^{us})^{nom}$.

The useful power of the dredge and jet pumps is determined by the dependence [4,9]:

$$\left. \begin{aligned} N_{DP}^{us} &= P_{DP}^w \cdot Q_{DP}^w \\ N_{JP}^{us} &= P_{JP} \cdot Q_{JP} \end{aligned} \right\} \quad (1)$$

where:

P_{DP}^w – dredge pump pressure specified for water,

Q_{DP}^w – volume efficiency of the dredge pump specified for water,

P_{JP} – pressure of the jet pump,

Q_{JP} – volume efficiency of the jet pump.

The power of the propulsor can be considered the towing power of the dredger hull N_{HD}^{us} expressed in dependence [7, 9]:

$$N_{HD}^{us} = R_{HD} \cdot v_{DR} \quad (2)$$

where:

R_{HD} – dredger hull resistance at assumed speed of movement,

v_{DR} – assumed speed of movement.

In the design assumptions for the needs of the shipowner for the hopper suction dredges, only the required speed of the dredger v_{DR} is given. As a result, it is necessary to look for the possibility of determining the drag resistance of the dredger hull. The author proposes the use of modified Admiralty method [1, 9], where the size of the suction hopper dredger will be the capacity of the hopper V_{HP} .

In the case of bow thrusters, useful power output use has been abandoned (not given in the technical dossier dredgers) in favor of nominal power thrusters, always given in the dredgers technical specification.

Tab. 1 gives linear regression equations describing the parameters of load distributions of main energy receivers of hopper suction dredger for individual works belonging to the state of “dredging works” [7, 8, 9].

Tab. 1. Linear regression equations that determine the load distribution parameters of the main power receivers of the hopper suction dredgers during the work involved in dredging works

Main receiver	Work type	Form of dependence
Propulsors of the main drive	Sailing between load and unload places	$(N_{PR}^{mn})^{sail} = 7,57 + 0,014 \cdot (V_{HP})^{2/3} \cdot (v_{DR})^{2,5}$
		$\sigma_{PR}^{sail} = -6,64 + 0,0024 \cdot (V_{HP})^{2/3} \cdot (v_{DR})^{2,5}$
	Loading	$(N_{PR}^{mn})^{load} = 18,41 + 0,01 \cdot (V_{HP})^{2/3} \cdot (v_{DR})^2$
		$\sigma_{PR}^{load} = -5,32 + 0,0015 \cdot (V_{HP})^{2/3} \cdot (v_{DR})^2$
Dredge pumps	Loading	$(N_{DP}^{mn})^{load} = 1,32 \cdot (N_{DP}^{us})^{load} - 26,34$
		$\sigma_{DP}^{load} = 0,041 \cdot (N_{DP}^{us})^{load} + 17,1$
	unloading	$(N_{DP}^{mn})^{unload} = 0,712 \cdot (N_{DP}^{us})^{unload} + 2,43$
		$\sigma_{DP}^{unload} = 0,076 \cdot (N_{DP}^{us})^{unload} + 22,01$
Jet pumps	Loading and unloading	$N_{JP}^{mn} = 0,89 \cdot N_{JP}^{us} + 6,46$
		$\sigma_{JP} = 0,036 \cdot N_{JP}^{us} + 2,57$
Bow thrusters	Loading	$(N_{BT}^{mn}) = 0,685 \cdot N_{BT}^{nom}$
		$\sigma_{BT} = 0,1 \cdot N_{BT}^{nom}$
	unloading	$(N_{BT}^{mn}) = 0,503 \cdot N_{BT}^{nom}$
		$\sigma_{BT} = 0,09 \cdot N_{BT}^{nom2}$

Acceptable ranges of variable values independent of the equations given in tab. 1 are shown in tab. 2.

Tab 2. Acceptable ranges of variable values independent of the equations given in tab. 1

Independent variable	Value range
V_{HP}	350–13700 m ³
V_{DR}	9–15,5 knots
$(N_{DP}^{us})^{load}$	68,2–1817 kW
$(N_{DP}^{us})^{unload}$	203,5–5084 kW
(N_{JP}^{us})	25–1290 kW
N_{BT}^{nom}	350–1000 kW

OPERATION PARAMETERS OF MAIN ENGINE LOADS

In general, the main engine of the main propulsion system maintains the main drive for the energy receivers and may, to a certain extent, cover the energy demand generated by the groups of auxiliary electric power generators. The parameters of the total load distribution of the main engines for the considered operating state, according to the general principle determining the parameters of the combined normal distribution [1, 9], will be:

$$\left. \begin{aligned} N_{ME,\Sigma}^{mn} &= \sum_{i=1}^n \frac{N_{MR,i}^{mn} \cdot \lambda_{MR,i}^{os}}{(\eta_{MR}^{TM})_i} + \varphi_e \cdot \frac{N_{EL}^{mn} \cdot \lambda_{GP}^{os}}{\eta_{GP} \cdot \eta_{GB}} \\ \sigma_{ME,\Sigma} &= \sqrt{\sum_{i=1}^n \left(\frac{\sigma_{MR,i} \cdot \lambda_{MR,i}^{os}}{(\eta_{MR}^{TM})_i} \right)^2 + \left(\varphi_e \cdot \frac{\sigma_{EL} \cdot \lambda_{GP}^{os}}{\eta_{GP} \cdot \eta_{GB}} \right)^2} \end{aligned} \right\} \quad (3)$$

where:

$N_{ME,\Sigma}^{mn}, \sigma_{ME,\Sigma}$ – mean value and standard deviation of the normal total load distribution of the main engine,

$N_{MR,i}^{mn}, \sigma_{MR,i}$ – mean value and standard deviation of the normal load distribution of the i-th main receiver,

N_{EL}^{mn}, σ_{EL} – mean value and standard deviation of the normal distribution of electricity demand generated by all groups of auxiliary receivers, the method of determining the electrical demand of the hopper suction dredgers is presented in [2,9],

φ_e – coefficient determining the share of electrical power demand covered by generators (or power hydraulics pumps) driven by the main engine,

$\lambda_{MR,i}^{os}, \lambda_{GP}^{os}$ – coefficients determining the share of working time of the i-th main energy receiver, e.g. generator or pump driven by the main engine in the considered operating state,

$(\eta_{MR}^{TM})_i$ – efficiency of the power transmission system to drive the i-th main power receiver,
 η_{GP}, η_{GB} – generator (pump) efficiency, gearbox efficiency.

Parameters of load distribution with the power of the main engines refer to the engine operating time during the “dredging” condition ($\tau_{ME}^{dr} = \lambda_{ME}^{dr} \cdot \tau_{dr}$), to the power of the main engine coupler (main engine couplings). In the case of hopper suction dredgers, “dredging works” are to be divided into three works performed during these activities: loading, hydraulic unloading and moving between the loading and unloading sites. Hence, the operating time of the main engines for this type of dredgers will be defined as: $\tau_{ME}^{load}, \tau_{ME}^{unload}, \tau_{ME}^{sail}$.

The impact of variants of energy system solutions is expressed in different, depending on the variant, values $(\eta_{MR}^{TM})_i$ of individual major energy consumers. Major receivers of this kind may, in certain applications, be driven in a variety of complex power transmission systems. The efficiency of such a system (composed of j elements loaded simultaneously – the serial functional structure) is [9]:

$$\eta_{MR}^{TM} = \prod_{j=1}^n (\eta_j) \quad (4)$$

where: η_j – efficiency of the j-th power transmission system element.

Each applied element of this system is characterized by a specific course of its performance depending on the load being transferred. Knowing the performance characteristics of the individual components of a complex power transmission system, it is possible to determine the course of the power transmission performance across the power range $(N_{MR}^{TM})_{min} \div (N_{MR}^{TM})_{max}$ using the relationship (4).

If the efficiency difference of the power transmission system $\Delta \eta_{MR}^{TM}$ is small (generally no more than 5-10% [9]), then the mean $(\eta_{MR}^{TM})_{mn}$ of the efficiency can be used. The average value is calculated as the weighted average [9]:

$$(\eta_{MR}^{TM})_{mn} = \frac{\sum_{i=1}^n (\eta_{MR}^{TM})_i \cdot p_i}{\sum_{i=1}^n p_i}, \quad (5)$$

where:

$(\eta_{MR}^{TM})_i$ – Performance of the power transmission system in the i-th range $(N_{MR}^{TM})_{min} \div (N_{MR}^{TM})_{max}$,

p_i – load frequency in the i-th main receiver load range.

The coefficient φ_e in equation (3) informs the variant of the solution of the dredging power system in the sense of the principles of electric power generation by the main propulsion system, to cover its demand for auxiliary energy receivers. The value of this factor $0 \leq \varphi_e \leq 1$ [9].

Definitely most of the power solutions of hopper suction dredgers are the power plants characterized by a high degree of centralization of the drive of main receivers and a high degree of integration of power systems. In such systems there is one main engine, or equivalent main engine multi-engine, to drive all the main dredgers present in the dredge, simultaneously covering the electricity demand generated by the auxiliary energy receivers. Trapezoidal suction dredges are commonly used for twin-screw propulsion systems, so there are no single-engine propulsion systems.

In this case, we can talk about four possible variants of the power plant solutions for hopper suction dredgers:

- variant I in which all the energy needed to drive all the main receivers as well as the auxiliary energy receivers is generated by 2-3 generating sets (diesel-electric power station) – fig. 1;
- variant II, in which propulsors of the main propulsion are driven by two main engines in the diesel-mechanical systems (through mechanical transmissions), and the remaining main propulsors of the propulsion are driven by diesel-electric systems (fig. 2);
- variant III, in which two main energy receivers: main propulsors and dredge pumps, are driven by two main engines in the diesel-mechanical systems; the other energy receivers are driven by diesel-electric systems (fig. 3);
- variant IV, where up to three main energy receivers (main propulsors, dredge and jet pumps) are driven by two main engines in the diesel-mechanical systems, and bow thrusters are driven by diesel-electric system. One main engine drives propulsion through the gearbox and the other through a multi-speed gear pump, the second engine also propels the propulsor and uses a second gearbox to propel the jet pumps (fig. 4).

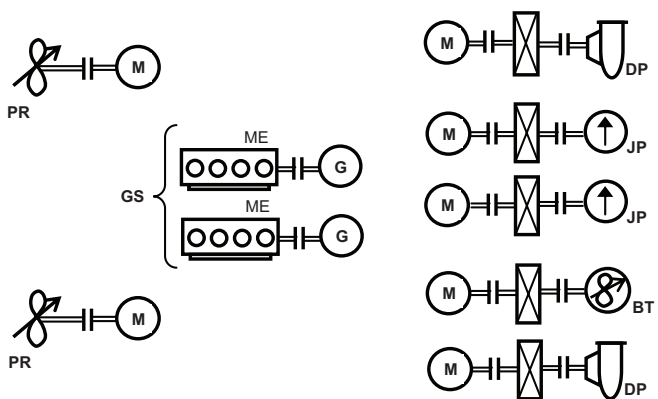

Fig. 1. Schematic diagram of variant I of the power plant; GS – gensets, ME – main engine, PR – propulsor, DP – dredge pump, JP – jet pump, BT – bow thruster

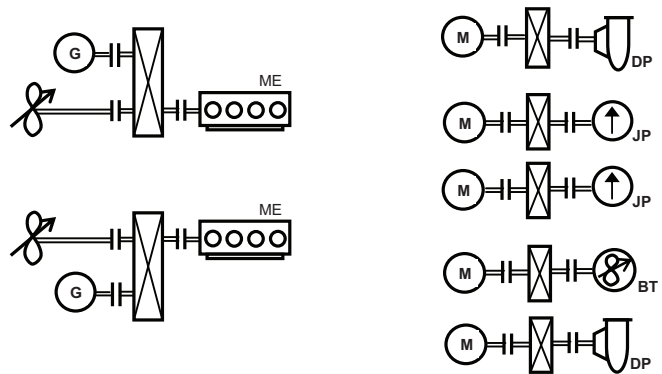

Fig. 2. Schematic diagram of variant II of the power plant; ME – main engine, PR – propulsor, DP – dredge pump, JP – jet pump, BT – bow thruster

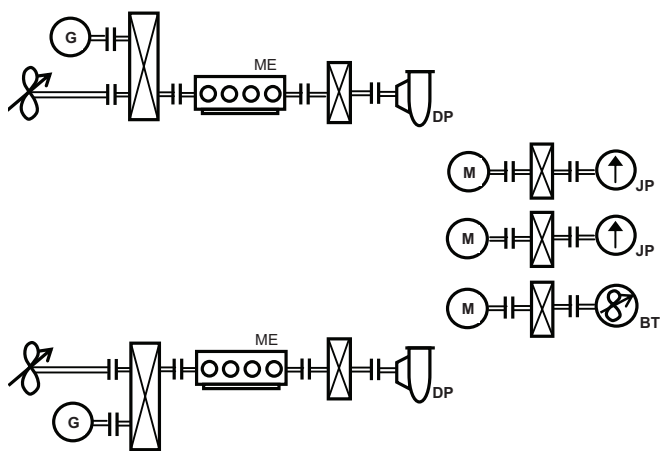

Fig. 3. Schematic diagram of variant III of the power plant; ME – main engine, PR – propulsor, DP – dredge pump, JP – jet pump, BT – bow thruster

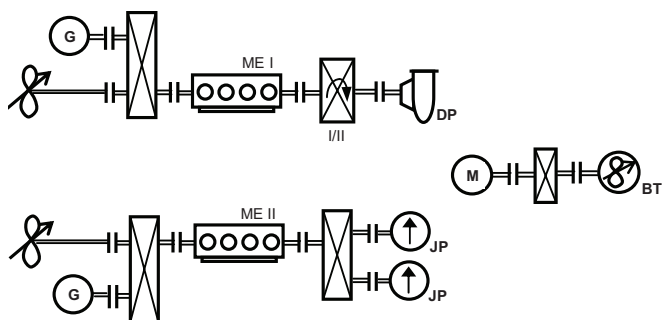

Fig. 4. Schematic diagram of variant IV of the power plant; ME – main engine, PR – propulsor, DP – dredge pump, JP – jet pump, BT – bow thruster

By limiting to these four variants of the engine room solutions of the hopper suction dredgers, dependencies (3) can be transformed into dependencies describing the parameters of the load distribution of the main engines for the three works belonging to the “dredging” state. For variants I, II and III these will be [9]:

- loading

$$\left. \begin{aligned} (N_{ME}^{mn})^{load} &= \frac{(N_{PR}^{mn})^{load} \cdot \lambda_{PR}^{load}}{\eta_{PR}^{TM}} + \frac{(N_{DP}^{mn})^{load} \cdot \lambda_{DP}^{load}}{\eta_{DP}^{TM}} + \frac{(N_{JP}^{mn})^{load} \cdot \lambda_{JP}^{load}}{\eta_{JP}^{TM}} + \frac{(N_{BT}^{mn})^{load} \cdot \lambda_{BT}^{load}}{\eta_{BT}^{TM}} + \varphi_e \cdot \frac{N_{EL}^{mn} \cdot \lambda_{GP}^{load}}{\eta_{GP} \cdot \eta_{GB}} \\ (\sigma_{ME}^{load}) &= \sqrt{\left(\frac{\sigma_{PR}^{load} \cdot \lambda_{PR}^{load}}{\eta_{PR}^{TM}}\right)^2 + \left(\frac{\sigma_{DP}^{load} \cdot \lambda_{DP}^{load}}{\eta_{DP}^{TM}}\right)^2 + \left(\frac{\sigma_{JP}^{load} \cdot \lambda_{JP}^{load}}{\eta_{JP}^{TM}}\right)^2 + \left(\frac{\sigma_{BT}^{load} \cdot \lambda_{BT}^{load}}{\eta_{BT}^{TM}}\right)^2 + \left(\varphi_e \cdot \frac{\sigma_{EL} \cdot \lambda_{GP}^{load}}{\eta_{GP} \cdot \eta_{GB}}\right)^2} \end{aligned} \right\} (6)$$

- hydraulic unloading

$$\left. \begin{aligned} (N_{ME}^{mn})^{unload} &= \frac{(N_{DP}^{sr})^{unload} \cdot \lambda_{DP}^{unload}}{\eta_{DP}^{TM}} + \frac{(N_{JP}^{mn})^{unload} \cdot \lambda_{JP}^{unload}}{\eta_{JP}^{TM}} + \frac{(N_{BT}^{mn})^{unload} \cdot \lambda_{BT}^{unload}}{\eta_{BT}^{TM}} + \varphi_e \cdot \frac{N_{EL}^{mn} \cdot \lambda_{GP}^{unload}}{\eta_{GP} \cdot \eta_{GB}} \\ (\sigma_{ME}^{unload}) &= \sqrt{\left(\frac{\sigma_{DP}^{unload} \cdot \lambda_{DP}^{unload}}{\eta_{DP}^{TM}}\right)^2 + \left(\frac{\sigma_{JP}^{unload} \cdot \lambda_{JP}^{unload}}{\eta_{JP}^{TM}}\right)^2 + \left(\frac{\sigma_{BT}^{unload} \cdot \lambda_{BT}^{unload}}{\eta_{BT}^{TM}}\right)^2 + \left(\varphi_e \cdot \frac{\sigma_{EL} \cdot \lambda_{GP}^{unload}}{\eta_{GP} \cdot \eta_{GB}}\right)^2} \end{aligned} \right\} (7)$$

- moving between loading and unloading

$$\left. \begin{aligned} (N_{ME}^{mn})^{sail} &= \frac{(N_{PR}^{mn})^{sail} \cdot \lambda_{PR}^{sail}}{\eta_{PR}^{TM}} + \varphi_e \cdot \frac{N_{EL}^{mn} \cdot \lambda_{GP}^{sail}}{\eta_{GP} \cdot \eta_{GB}} \\ (\sigma_{ME}^{sail}) &= \sqrt{\left(\frac{\sigma_{PR}^{sail} \cdot \lambda_{PR}^{sail}}{\eta_{PR}^{TM}}\right)^2 + \left(\varphi_e \cdot \frac{\sigma_{EL} \cdot \lambda_{GP}^{sail}}{\eta_{GP} \cdot \eta_{GB}}\right)^2} \end{aligned} \right\} (8)$$

For variant IV for moving between loading and unloading relation (8) is valid, for the other two works applies dependency [9]:

- loading

$$\left. \begin{aligned} (N_{ME}^{mn})_I^{load} &= \frac{(N_{PR}^{mn})^{load} \cdot \lambda_{PR}^{load}}{2 \cdot \eta_{PR}^{TM}} + \frac{(N_{DP}^{mn})^{load} \cdot \lambda_{DP}^{load}}{\eta_{DP}^{TM}} + \varphi_e \cdot \frac{N_{EL}^{mn} \cdot \lambda_{GP}^{load}}{2 \cdot \eta_{GP} \cdot \eta_{GB}} \\ (\sigma_{ME}^{load})_I &= \sqrt{\left(\frac{\sigma_{PR}^{load} \cdot \lambda_{PR}^{load}}{2 \cdot \eta_{PR}^{TM}}\right)^2 + \left(\frac{\sigma_{DP}^{load} \cdot \lambda_{DP}^{load}}{\eta_{DP}^{TM}}\right)^2 + \left(\varphi_e \cdot \frac{\sigma_{EL} \cdot \lambda_{GP}^{load}}{2 \cdot \eta_{GP} \cdot \eta_{GB}}\right)^2} \end{aligned} \right\} (9)$$

$$\left. \begin{aligned} (N_{ME}^{mn})_{II}^{load} &= \frac{(N_{PR}^{mn})^{load} \cdot \lambda_{PR}^{load}}{2 \cdot \eta_{PR}^{TM}} + \frac{(N_{JP}^{mn})^{load} \cdot \lambda_{JP}^{load}}{\eta_{JP}^{TM}} + \frac{(N_{BT}^{mn})^{load} \cdot \lambda_{BT}^{load}}{\eta_{BT}^{TM}} + \varphi_e \cdot \frac{N_{EL}^{mn} \cdot \lambda_{GP}^{load}}{2 \cdot \eta_{GP} \cdot \eta_{GB}} \\ (\sigma_{ME}^{load})_{II} &= \sqrt{\left(\frac{\sigma_{PR}^{load} \cdot \lambda_{PR}^{load}}{2 \cdot \eta_{PR}^{TM}}\right)^2 + \left(\frac{\sigma_{JP}^{load} \cdot \lambda_{JP}^{load}}{\eta_{JP}^{TM}}\right)^2 + \left(\frac{\sigma_{BT}^{load} \cdot \lambda_{BT}^{load}}{\eta_{BT}^{TM}}\right)^2 + \left(\varphi_e \cdot \frac{\sigma_{EL} \cdot \lambda_{GP}^{load}}{2 \cdot \eta_{GP} \cdot \eta_{GB}}\right)^2} \end{aligned} \right\} (10)$$

- hydraulic unloading

$$\left. \begin{aligned} (N_{ME}^{sr})_I^{unload} &= \frac{(N_{DP}^{mn})^{unload} \cdot \lambda_{DP}^{unload}}{\eta_{DP}^{TM}} + \varphi_e \cdot \frac{N_{EL}^{mn} \cdot \lambda_{GP}^{unload}}{2 \cdot \eta_{GP} \cdot \eta_{GB}} \\ (\sigma_{ME}^{unload})_I &= \sqrt{\left(\frac{\sigma_{DP}^{unload} \cdot \lambda_{DP}^{unload}}{\eta_{DP}^{TM}}\right)^2 + \left(\varphi_e \cdot \frac{\sigma_{EL} \cdot \lambda_{GP}^{unload}}{2 \cdot \eta_{GP} \cdot \eta_{GB}}\right)^2} \end{aligned} \right\} (11)$$

$$\left. \begin{aligned} (N_{ME}^{mn})_{II}^{unload} &= \frac{(N_{JP}^{mn})^{unload} \cdot \lambda_{JP}^{unload}}{\eta_{JP}^{TM}} + \frac{(N_{BT}^{mn})^{unload} \cdot \lambda_{BT}^{unload}}{\eta_{BT}^{TM}} + \varphi_e \cdot \frac{N_{EL}^{mn} \cdot \lambda_{GP}^{unload}}{2 \cdot \eta_{GP} \cdot \eta_{GB}} \\ (\sigma_{ME}^{unload})_{II} &= \sqrt{\left(\frac{\sigma_{JP}^{unload} \cdot \lambda_{JP}^{unload}}{\eta_{JP}^{TM}}\right)^2 + \left(\frac{\sigma_{BT}^{unload} \cdot \lambda_{BT}^{unload}}{\eta_{BT}^{TM}}\right)^2 + \left(\varphi_e \cdot \frac{\sigma_{EL} \cdot \lambda_{GP}^{unload}}{2 \cdot \eta_{GP} \cdot \eta_{GB}}\right)^2} \end{aligned} \right\} (12)$$

SELECTION OF NUMBER AND SIZE OF MAIN ENGINES

The design value (nominal) of power of the main engine in the case of a single-engine powertrain can be determined from the dependence [9]:

$$(N_{ME}^{nom})^{design} = \frac{N_{ME}^{mn}}{(\bar{N}_{ME}^{mn})^{design}} \quad (13)$$

In the case of a group consisting of several engines, the power given by the relation (13) allows to determine the total nominal power (design) of the main engines ($\sum N_{ME}^{nom})^{design}$. This value corresponds to the combined nominal power of the largest number of operating engines and to the drive of certain main receivers and suspended generators.

The dependent (13) value $(\bar{N}_{ME}^{mn})^{design}$ is determined on the basis of the operating values \bar{N}_{ME}^{mn} of the main engines tested [6,7,9], taking into account the value of the ratio $N_{ME}^{max} / N_{ME}^{nom}$ (which is the ratio of the maximum operating power of the main motors to their nominal power) and the acceptance at an appropriate level of main engine power reserve ΔN_{ME} . The value of this reserve depends on the operating conditions and the nature of the load changes driven by the main engine of the main power receivers. The value ΔN_{ME} of power systems with a high degree of centralization of the main receivers and a high degree of integration of power systems is 0.15 [9], hence the value $(\bar{N}_{ME}^{mn})^{design}$ can be assumed to be 0.65-0.7 [9].

The second way to determine the design value of the nominal power of the main engine is to determine it from the dependence [9]:

$$(N_{ME}^{nom})^{design} = (N_{ME}^{mn} + \beta_{ME} \cdot \sigma_{ME}) + \Delta N_{ME} \quad (14)$$

where:

β_{ME} - coefficient of relative range of maximum loads, acceptance of value $\beta = 3$ allows to determine the maximum load with probability 0,997;

ΔN_{ME} - reserve power of the main engine.

For variants I, II and III the number of main engines in the case of the selection of identical engines, their calculated nominal power will be [9]:

$$(N_{ME}^{nom})_m^{design} = \frac{(\sum N_{ME}^{nom})^{design}}{m} \quad (15)$$

where: $m = 1, 2, \dots$

In the case of selection of engines of different sizes (variant I only) [9]:

$$\sum_{m=1}^n (N_{ME}^{nom})_m^{design} = (\sum N_{ME}^{nom})^{design} \quad (16)$$

In case of variant IV we can say that we have two different single-engine power trains in which the nominal power of the main engine is determined by the dependence (13).

It should be noted, that if one analyzes different variants of drive solutions for major energy receivers, the values $(\sum N_{ME}^{nom})^{design}$ will differ from one another because of different efficiency values $(\eta_{MR}^{TM})_m$ (bypassing the potential demand for auxiliary power receivers). This means that the analyzed variants of the main propulsion drive solutions will be equivalent in nominal power to the main receivers and will differ by the total nominal power of the main engines.

CONCLUSIONS

The presented method can be applied in design practice, mainly at the initial stages of designing hopper suction dredgers. The advantages of the method are:

- the use of probabilistic models, better describing the complex and variable realities of exploitation of dredgers,
- use experimental research to build the above models,
- the need to know only those parameters that are given in the ship's design assumptions.

Using the proposed method, one can analyze many different variants of the engine solutions in different configurations of the main engines. The objective of choosing the best solution is to use the economic efficiency indicator method, which will take into account the investment and operating costs of the variants.

BIBLIOGRAPHY

1. Balcerski A.: *Modele probabilistyczne w teorii projektowania i eksploatacji spalinowych siłowni okrętowych*. Gdańsk: Wyd. Fundacji Promocji Przemysłu Okrętowego i Gospodarki Morskiej 2007.
2. Bocheński D.: *Demand determination for electrical energy for trailing suction hopper dredgers*. W: [Mat.] IV International Scientific-Technical Conference EXPLO DIESEL & GAS TURBINE '05, Gdańsk-Międzyzdroje-Kopenhaga 2005.
3. Bocheński D.: *Operational loads of diesel engines on trailing suction hopper dredgers in their main service states*. Journal of Polish CIMAC, Energetic Aspects vol. 3, nr 1, Gdańsk 2008.
4. Bocheński D.: *Operational loads of dredge pumps in their basic service states on selected types of dredgers*. Journal of Polish CIMAC, Energetic Aspects vol. 3, nr 1, Gdańsk 2008.
5. Bocheński D.: *Eksplatacyjne obciążenia śrub napędowych pogłębiarek różnych typów w podstawowych stanach ich eksploatacji*. Zesz. Nauk. Akademii Morskiej w Szczecinie 2009, nr17 (89), XXIX Sympozjum Siłowni Okrętowych SymSO 2008.
6. Bocheński D.: *Operational loads of diesel engines on trailing suction hopper dredgers in their main service states*. Journal of Polish CIMAC, Energetic Aspects vol. 3, nr 1, Gdańsk 2008.
7. Bocheński D.: *Określanie parametrów rozkładów eksploatacyjnych obciążeń napędu własnego pogłębiarek ssących nasiębiernych podczas robót pogłębiarskich*. Zesz. Nauk. Akademii Marynarki Wojennej w Gdyni 2009, nr 178/A, XXX Sympozjum Siłowni Okrętowych SymSO 2009.
8. Bocheński D.: *Determination of operational load parameters of dredge pumps under dredging operations*. Journal of Polish CIMAC, Energetic Aspects vol. 4, nr 1, Gdańsk 2009.
9. Bocheński D.: *Projektowanie wstępne siłowni pogłębiarek z zastosowaniem metod i modeli probabilistycznych*. Politechnika Gdańska, seria monografie 142, Gdańsk 2013.
10. Harrington R. L.: *Marine Engineering*. The Society of Naval Architects and Marine Engineers 1992.
11. Jamroz J., Swolkień T., Wieszczyński T.: *Projektowanie siłowni okrętowych*. Gdańsk: Wyd. Polit. Gdańskiej 1992.
12. Taylor D. A.: *Introduction to Marine Engineering*. Oxford: Elsevier Butterworth-Heinemann 1996.
13. Urbański P.: *Podstawy napędu statków*. Gdynia: Wyd. Rozwoju AM w Gdyni 2005.
14. Woud H. K., Stapersma D.: *Design of propulsion and electric power generation systems*. London: IMarEST 2002.
15. Vlasblom W. J.: *Designing dredging equipment*. Lecture notes Wb3408, TUDelft 2003-05.
16. Vlasblom W. J., Pinkster J.: *Dredgers*, chapter 51 "Ship design and construction" vol. II. The Society of Naval Architects and Marine Engineers, New York 2004.
17. Welte A.: *Nassbaggertechnik*. Karlsruhe: Institut für Maschinenwesen in Baubetrieb, Universität Fridericiana 1993.
18. Project Guide PROPAC, Wartsila Finland 2006.
19. Project Guide Wartsila 32, Wartsila Finland Oy 2010.
20. Project Guides 2008. DVD Video, MAN Diesel 2008.
21. Wartsila 20-Product Guide, Wartsila Finland Oy 2009.
22. Wartsila 26-Product Guide, Wartsila Finland Oy 2009.

CONTACT WITH THE AUTHORS

Damian Bocheński

Gdańsk University of Technology
11/12 Narutowicza St.
80 - 233 Gdańsk
POLAND