

## AERODYNAMIC PERFORMANCE OF A NEW DOUBLE-FLAP WING SAIL

**Dongqin Li**

School of Naval Architecture & Ocean Engineering, Jiangsu University of Science and Technology, China

**Yili Zhang**

Jiangsu University of Science and Technology, China

**Peng Li**

Jiangsu University of Science and Technology, China

**Jingjing Dai**

Jiangsu University of Science and Technology, China

**Guohuan Li**

Jiangsu University of Science and Technology, China

### ABSTRACT

*As a type of natural energy resource, wind power is used in the modern implementation of wind-assisted technologies as a method for reducing the fuel consumption and environmental pollution of ocean-going ships. In order to promote the full usage of ocean wind energy for cargo ships, an innovative type of ship propulsion-assisted wing sail is proposed in this paper. The propulsion efficiency of this new wing sail can be increased by enlarging its area in both the transverse and vertical directions in good weather conditions, and it can be folded up automatically in poor weather conditions, improving the sailing safety of the ship. The sail parameters relating to the gaps and rotation angles between different parts of the wing sail are compared, and the values giving the best aerodynamic performance are identified using CFD simulation technology. The results for the lift and drag coefficients for the new wing sail at different attack angles are also compared with those of traditional aerofoil sails, including an arc-shaped rigid sail and a variable-camber sail proposed in 2015. From the viewpoint of the sailing performance of the vessel, our results demonstrate that this new type of wing sail has good aerodynamic performance and can reduce fuel costs for commercial vessels.*

**Keywords:** double-flap wing sail, aerodynamic performance, Computational Fluid Dynamics (CFD), parameter optimization

### INTRODUCTION

Cargo shipping is an inexpensive and convenient way of transporting goods around the world. However, a negative impact has been observed in the shipping transport industry in terms of greenhouse gas emissions and harmful liquid substances. Many different kinds of measures and technologies have already been adopted on board ships for the purposes of energy saving and emission reduction [1].

As it is a renewable energy source and offers the possibility of environmental sustainability, wind power has been used for centuries to provide the main thrust through sail technology. Although sail-assisted propulsion is not currently considered to provide sufficient main thrust for large maritime shipping, it can offer considerable economic and environmental

advantages by reducing fuel consumption when coupled with conventional propulsion [2, 3]. Sails can produce the aerodynamic forces of drag  $D$  and lift  $L$  [4], both of which can be harnessed for towing, as illustrated in the coordinate system in Fig. 1. Here,  $\alpha$  means the attack angle,  $\beta$  the wind angle,  $X$  the forward force and  $Y$  the side force.

The issue of how to design new types of sail that can produce higher thrust and more reliable aerodynamic performance has become a research topic of considerable interest. The objective of this study is to investigate the aerodynamic performance of a proposed collapsible double-flap wing sail. Attention is paid to the design of the shapes of the three parts of the new wing sail, using a comparison of different mesh structures, mesh sizes and turbulence models, and the optimum combination of parameters under specific wind conditions is sought. In

terms of its automatic and flexible structural features, this new type of collapsible double-flap wing sail is designed to increase the propulsion efficiency by enlarging the area of the sail in the transverse and vertical directions when suitable wind conditions become available. It can also be folded up automatically in poor weather conditions to reduce the sail area in the transverse section and improve the sailing safety of the ship. This new wing sail is composed of three parts, the main, front and back wings. Using computational fluid dynamics (CFD), the sail parameters are investigated, including the gaps and rotation angles between its component parts, and the best parameters for excellent aerodynamic performance are determined.

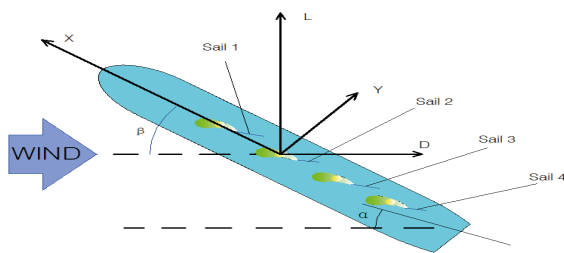

Fig. 1. Coordinate system of the cascade sails for an imaginary ship

## DEVELOPMENT OF SAIL-ASSISTED TECHNOLOGY

Although sails have been utilized for ship propulsion since ancient times, modern sail-assisted technology was put into use only in the 1970s, due to the first global oil crisis. It is well-known that high-performance modern sails with large wing areas can be efficient on these vessels, and that the type of sail greatly affects the aerodynamic performance and its application on board vessels.

A comparison of the maximum lift coefficients for various types of soft, hard and rotor sails, based on wind tunnel tests, was carried out by Bergeson and Greensward [5]. In 1985, Walker wing sails with an airfoil shape were proposed by John Walker; these were first used on a 3000-ton freighter called “MV Ashington” and can provide fuel savings of 15–25% [6]. In 1991, a wind-assisted ship propulsion device (WASP) consisting of a cylinder-flap wing was developed [7], and in 2005, a new hybrid sail [8] consisting of a slat, a hard sail and a oft sail was designed for advanced sail-assisted bulk carriers. Ouchi et al. [9] proposed a telescopic structure for hard sails in 2011, and in 2013, the same authors presented the “Wind Challenger” project [10], which investigated the use of wing sails for an 180,000 deadweight tonnage (DWT) bulk carrier. Li [4] proposed a type of hard sail called variable-camber sail in 2015, and investigated the performance of cascade sails.

From the above references, it is clear that the use of sail-assisted technologies can increase the ratio of the wind thrust to the thrust generated by the conventional engines, and can therefore decrease fuel consumption.

## SAIL TYPES AND SELECTION OF TARGET SHIPS

### SELECTION OF THE SAIL TYPE

The issue of how to choose a sail type to improve the ship’s propulsion efficiency is a major concern in the application of sail-assisted technology. Traditional soft sail propulsion can no longer be used in modern cargo shipping, due to the insufficient propulsion power generated and restrictions on deck space. Flettner rotors are used to provide auxiliary propulsion force by rotating with the aid of electric motors, but these may cause extra energy consumption. There are also some deficiencies when using kite devices, such as difficulties in launching and retrieving them. An investigation of the existing typical and innovative sail systems was undertaken [11], and the aerodynamic performance of different types of sail rig was compared. As a result of this investigation, a wing sail with flaps was chosen as our research target, based on its superior drag/lift ratio performance, and new design style was used that allows it to be folded in bad weather conditions.

### SELECTION OF THE TARGET SHIP

The particulars of the ship were used to define the initial dimensions and location of the wing sail. The candidate type of ship must have an open deck area, without extensive superstructure or deck machinery. The mounting site should also be carefully chosen to ensure that forces can be safely transferred to the ship’s structure.

Tab. 1. Characteristics of the target vessel

Characteristic	Dimension
Overall length	~199.99 m
Length between perpendiculars	192.00 m
Moulded breadth	32.26 m
Depth designed	15.40 m
Draft in full load	10.50 m
Speed design	13.0 kn
Deadweight	46,000 t

Tab. 2. Main dimensions of the wing sail

Characteristic	Dimension
Chord of the main wing	10 m
Chord of the front wing	6 m
Chord of the back wing	4 m
Total width	20 m
Height	24 m
Aspect ratio	1.2
Camber ratio	0.12

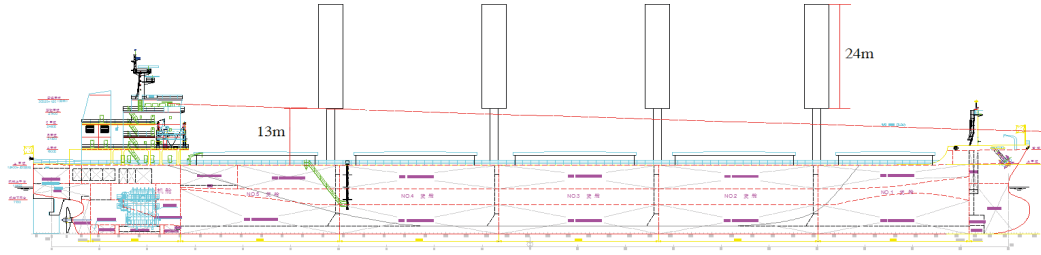
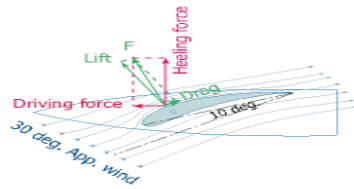

Fig. 2. General arrangement of the target vessel

A 45000DWT bulk carrier with five cargo holds was chosen as the target ship, with a distance between adjacent hatches of about 8 m. The characteristics of the target vessel are listed in Table 1, and the general arrangement is shown in Fig. 2. Based on the ship's characteristics, four sets of wing sails 20 m wide and 24 m high were installed on the target ship; the aspect ratio of the wing sails was 1.2 and the camber ratio 0.12. The main dimensions of the wing sails are shown in Table 2.

### ANALYSIS OF FORCES ON THE WING SAIL

As suggested by its name, a wing sail is similar to the wing of an aircraft. A force analysis at different wing angles is shown in Fig. 3. The forces acting on the ship are the thrust  $T$  and drift  $H$ , which can be derived from the lifting force  $F_L$  and drag force  $F_D$  of the sail. In the form of dimensionless indexes, these forces can be expressed as the lifting coefficient  $C_L$ , the drag coefficient  $C_D$ , the thrust coefficient  $C_T$  and the drift coefficient  $C_H$ .



(a) 30° apparent wind

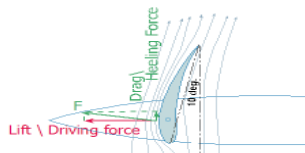

(b) 90° apparent wind

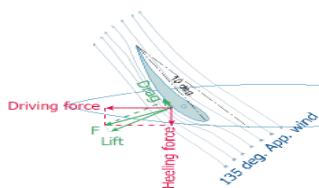

(c) 135° apparent wind

Fig. 3. Force analysis at different wing angles

The forces acting on the wing sail are shown in Fig. 4. The thrust and drift forces acting on the ship are as follows:

$$\begin{aligned} T &= F_L \cos \alpha + F_D \sin \alpha \\ H &= F_D \cos \alpha - F_L \sin \alpha \end{aligned} \quad (1)$$

The thrust and drift force coefficients can be expressed in the form of dimensionless indexes as

$$\begin{aligned} C_T &= C_L \sin \beta - C_D \cos \beta \\ C_H &= C_L \cos \beta + C_D \sin \beta \end{aligned} \quad (2)$$

where

$$\begin{aligned} C_L &= F_L / (0.5 \rho_a V_r^2 S) \\ C_D &= F_D / (0.5 \rho_a V_r^2 S) \\ C_T &= T / (0.5 \rho_a V_r^2 S) \\ C_H &= H / (0.5 \rho_a V_r^2 S) \end{aligned} \quad (3)$$

Here,  $C_T$ ,  $C_H$  and  $C_L$  and  $C_D$  are the thrust, drift, lift and drag force coefficients, respectively;  $\rho_a$  is the density of air ( $\text{kg}/\text{m}^3$ );  $S$  represents the total sail area ( $\text{m}^2$ );  $V_r$ ,  $V_s$  and  $V$  are the apparent wind velocity, ship velocity and absolute wind velocity ( $\text{m}/\text{s}$ );  $\beta$  is the apparent angle of wind (degrees);  $\alpha$  is the angle of attack (degrees);  $\gamma$  is the true wind angle (degrees);  $\delta$  is the angle between the center line of the ship and the chord of the sail; and  $b$  is the chord length of the whole wing ( $\text{m}$ ).

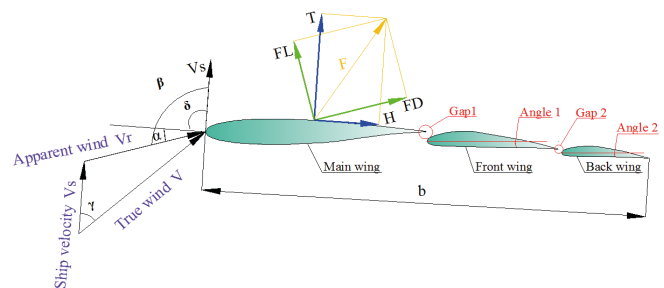

Fig. 4. Forces acting on the wing sail

### NEW DESIGN OF A DOUBLE-FLAP WING SAIL

Based on a comprehensive analysis of the main types of sail in the literature [11], a wing sail was demonstrated

to have advantages such as good performance in assisted propulsion, a simple structure and convenient operation. From the literature [12], it can be seen that the use of flaps in a wing sail can enlarge the overall wind area of the sail and change its camber to increase the lift force. Based on our research, a new type of collapsible wing sail with double flaps is proposed in this paper, using additional flaps. The profile of double-flap wing sail is shown in Fig. 4.

Our proposed wing sail has three components: the main, front and back wings. These wings were designed separately in order to enable the sail to fold in a retractable way. The area of the wing sail can be increased in the transverse and vertical directions when suitable wind conditions become available, and it can be folded up automatically poor weather conditions to reduce the wind area in the transverse section and improve the sailing safety of the ship.

### OPTIMIZATION OF THE MAIN WING

The front shape of the main wing maintains symmetry while the afterbody part has a certain arc degree, so the shape of the main wing needs to be designed separately. Two types of airfoils are used to form a new shape of wing sail. In general, a large camber ratio for the sail is advantageous; however, the transverse force and the yaw angle will be increased when the camber ratio is too large, meaning that the camber ratio is usually between 0.1 and 0.18 [13]. A camber ratio of 0.12 was selected for the main wing in our design. A NACA 0012 airfoil, one of the most widely used low-speed airfoils, was used as the symmetrical head of the main wing. Since the front and back wings need to be folded back into the main wing, the tail of the main wing has a certain degree of curvature. Thus, a low-speed GOE413 airfoil was selected as the shape of the tail of the main wing, with a high lifting coefficient. These two airfoils are combined to form a novel shape for the head and tail, as shown in Fig. 5.

### OPTIMIZATION OF THE DOUBLE-FLAP WING

A double-flap arrangement effectively increases the wind area of the wing sail and the camber of the wing, and improves the loading capacity of the main wing, thus enhancing the lift force. A low-speed airfoil is used in the design of the shape of the front wing, which is an integrated airfoil combining the NACA4412 and GOE413. The NACA4412 airfoil has a higher lift coefficient, while the airfoil of GOE413 has a certain degree of curvature in the back area, so this combined airfoil can be used as an alternative wing flap which can be easily folded back and fitted closely with the main wing. An integrated optimized section of the front wing is shown in Fig. 6.

Here, the back wing is designed in a similar way to the front wing, which is also a type of low-speed airfoil. The NACA 4412 airfoil is chosen for this section. The front shape of the back wing has the same curvature as the back shape of the front wing, so that the back wing can be folded back to the front wing. The optimized section of the back wing is shown in Fig. 7.

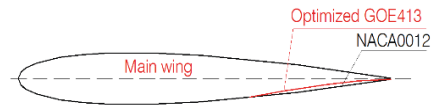

Fig. 5. Optimized sectional view of the main wing

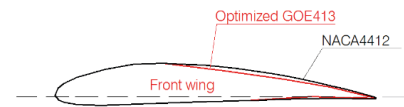

Fig. 6. Optimized sectional view of the front wing

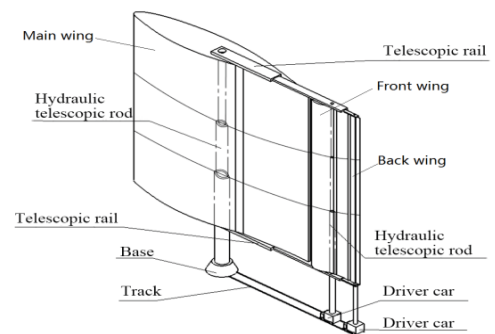

Fig. 7. Optimized sectional view of the back wing

### EXPANSION AND FOLDING MECHANISMS

This new type of collapsible wing sail is based on a rotating frame mast. The two flap wings can be folded back together with the main wing to reduce the area in bad weather or near a harbor. All three wings can be slid up and down the mast together. The frame structure and folding status of the wing sail are shown in Fig. 8.

Depending on the available deck space and other restrictions, multiple sets of this new wingsail may be deployed on the target vessel. The lift force can be maximized by rotating the sail to the optimum angle of attack. Wing sails can also be used as 'brakes' to slow down the vessel, if needed, instead of using the engine astern.



(a) Frame structure (expanded status)

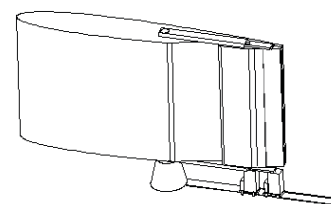

(b) Folded status (side view)



(c) Folded status (top view)

Fig. 8. Expansion and folding of the wing sail

## CFD SIMULATION AND PARAMETER OPTIMIZATION

In our research, a computational fluid dynamics (CFD) numerical simulation method was used to evaluate the aerodynamic performance of our new type of wing sail, as this approach has been demonstrated as being accurate and efficient. First, we used the professional CFD software STAR CCM+ for the aerodynamics calculations for the normal NACA0012 wing type, in order to test and verify the accuracy of the simulation. This software was then used to simulate the aerodynamic forces on our new type of wing sail, with different parameter combinations and attack angles. The NACA0012 airfoil was chosen as the calculation object, and the results for the lifting and drag coefficients at an angle of attack of 15°, using different turbulence models, mesh topology structures and mesh sizes, were compared with experimental data. The results are listed in Table 3 and illustrated in Fig. 9.

Tab. 3. Lift and drag forces under different conditions

Turbulence model	$F_L$	$F_D$	Mesh topology	$F_L$	$F_D$	Mesh size	$F_L$	$F_D$
SST	1.41	0.23	Structured mesh	1.51	0.32	Small mesh size (130,000)	1.25	0.37
SA	1.46	0.22	Unstructured mesh	1.58	0.37	Medium mesh size (500,000)	1.41	0.22
Standard k-ε	1.61	0.48	Hybrid mesh	1.47	0.29	Large mesh size (750,000)	1.42	0.23
Experimental values	1.43	0.23	Experimental values	1.43	0.23	Experimental values	1.43	0.23

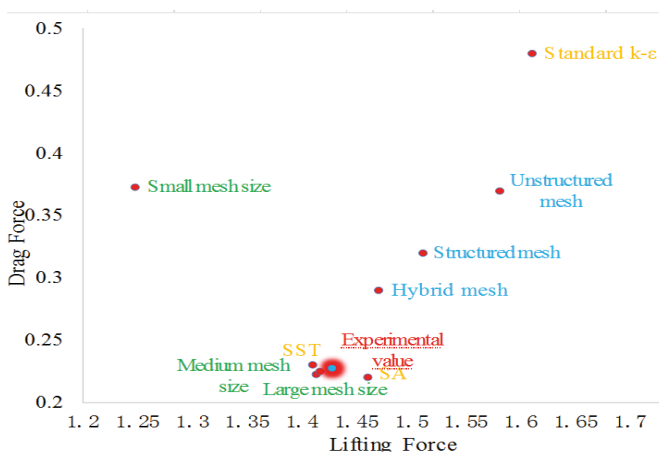
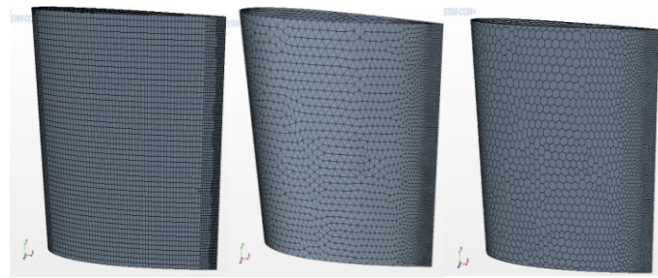

Fig. 9. Comparison of different grid settings and turbulence models



(a) Structured mesh (b) Unstructured mesh (c) Hybrid mesh

Fig. 10. Mesh structure using different topologies

In order to determine the influence of the turbulence model on the accuracy of the results, the SA, SST and standard k- $\omega$  turbulence models were chosen for comparison. The topological structure of the mesh also has a very important influence on the accuracy of the CFD calculation results. As shown in Fig. 10, structural, unstructured and hybrid meshes were used, in order to explore their effects on the CFD calculation, and the SST turbulence model was used to calculate the lift and drag coefficients of NACA0012 for different mesh topology structures.

From Table 3, we can see that the lift and drag forces calculated by the SST turbulence model are closer to the experimental values, and are more accurate than the other two turbulence models. Furthermore, the double-flap wing sail proposed in this paper is a complicated object with multi-section airfoils; a hybrid mesh was therefore adopted in which the key areas were filled with structured meshes and the other

regions with unstructured mesh. A suitable mesh size was then chosen for simulation of the new wing sail.

## PARAMETER OPTIMIZATION FOR THE WING SAIL

Since different combinations of parameters can greatly affect the aerodynamic performance of the double-flap wing sail, the control variable method [12] was used to solve this multi-parameter optimization problem, in which each parameter was changed individually while the others remained unchanged.

The parameters of the new wing sail include the front wing angle (Angle 1), the back wing angle (Angle 2), the gap (Gap 1) between the main and front wings, and the gap (Gap 2) between the front and back wings, as shown in Fig. 4. In this section, the influence of each parameter on the total aerodynamic performance of the wing sails is discussed

using the control variable method. The numerical model of the wing sail used in this paper is based on a scale ratio of 1:50. Computations were run in the STAR CCM+ CFD software for an incoming wind speed of 10 m/s. The lift and drag coefficients with different parameters and angles of attack were simulated in this CFD software, and an optimized parameter combination was obtained.

Using Eqs. (1), (2) and (3), the maximum thrust coefficient and the corresponding drift force coefficient of the sail model were calculated for different apparent wind angles  $\theta$ . As in reference [12], the front wing angle (Angle 1) and the back wing angle (Angle 2) were both set to 0°, 2°, 4° and 6°, while the gap between the main and front wings (Gap 1) and the gap between the front and back wings (Gap 2) were set to 3% C, 5% C and 8% C, where C is the chord length of the main wing (m). Different combinations of these parameters will result in different aerodynamic performance of the wing sail. Since space was limited, the range of the wind angle was kept between 40° and 140°, with a measuring interval of 10°, and the thrust and drift force coefficients for certain parameter combinations are shown in Fig. 11. As can be seen from the figure, the change in the thrust force coefficient is significant when the wind angle is 40°–120°, while thrust force coefficient is greatly improved when the wind angle is above 80° with sail gaps 5% C, and reaches maximum value when the wind angle is 110° with Angle 1 set to 2° and Angle 2 set to zero. With an increase in the wind angle, the drift force coefficients for different gaps are reduced accordingly.

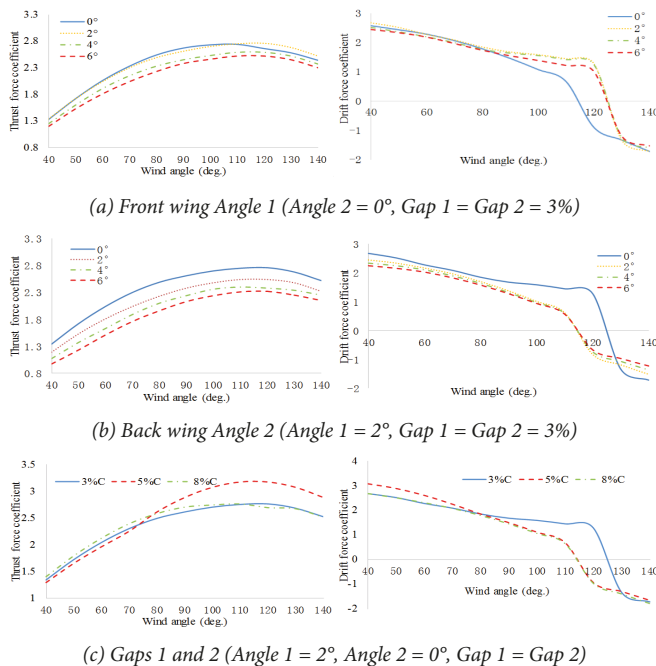

Fig. 11. Thrust and drift force coefficients for different parameters

Tab. 4. Simulation results for optimum coefficients

Wind angle (°)	Lift coefficient $C_L$	Drag coefficient $C_D$
0	-0.30	0
5	0.80	0.04
10	0.55	0.07

Wind angle (°)	Lift coefficient $C_L$	Drag coefficient $C_D$
15	0.57	0.13
20	0.70	0.23
25	1.27	0.40
30	1.60	0.60
35	1.68	0.80
40	1.33	1.00
50	0.88	1.38
60	0.72	1.64
70	0.44	1.85
80	0.18	2.24
90	-0.12	2.32

After comparing the simulation results for different parameters, the optimal combination of sail parameters (Angle 1 = 2°, Angle 2 = 0°, Gap 1 = Gap 2 = 3% C) was chosen for the specific condition of apparent wind speed. The results for the optimum lift and drag coefficients are listed in Table 4, while a mesh model of our proposed wing sail is shown in Fig.12.

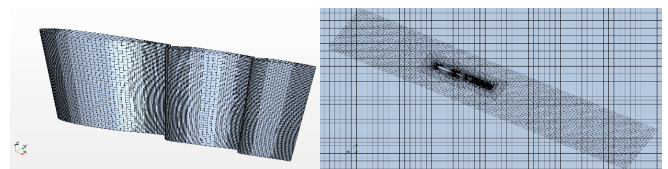

(a) Geometric model of the sail (b) Computational domain mesh

Fig. 12. Mesh model of the new wing sail

## COMPARISON AND ANALYSIS

In order to evaluate the performance of our new wing sail, the calculation results were compared with those for traditional sail types (NACA0012 and arc sail) and a variable-camber sail [4]. The aerodynamic performance results are shown in Fig. 13. It is worth mentioning that the variable-camber sail is the most recent sail type in the literature, and was proposed by Japanese researchers in 2015 [4].

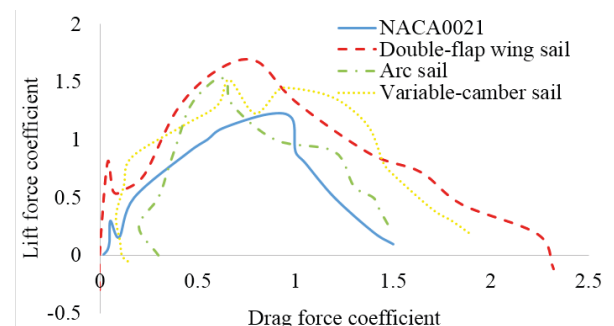
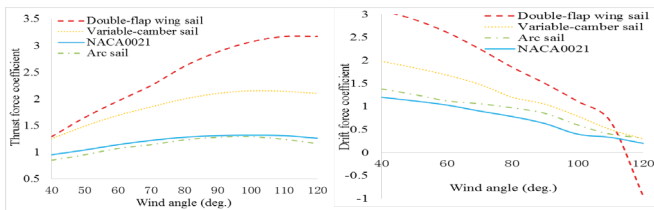

Fig.13. Lift and drag coefficients for the four sails

As can be seen from the above figure, the lift and drag force coefficients are superior to other traditional types of sails

and the recently designed variable-camber sail. Especially in downwind conditions, the drag force may also form part of the propulsion force for the ship. In order to further verify the thrust performance of the new sail, the lift and drag force coefficients were converted to the thrust and drift coefficients using Eqs. (1), (2) and (3). When the wind angle was between 40° and 120°, the thrust from the wing sail was conducive to propulsion of the ship. The values of the thrust and drift coefficient values at wind angles of 40°–120° are shown in Fig. 14. It can be seen that the thrust coefficient of the new wing sail can reach 3.17 when the wind angle is 110°, which is much higher than the values for the traditional and variable-camber sails.



(a) Thrust force coefficient (b) Drift force coefficient

Fig. 14. Comparison of thrust and drift force coefficients

We also compared the results for the proposed double-flap wing sail with those of the variable-camber, NACA0021 and arc sails, and the results are shown in Fig. 15. The relative error (RE) is calculated as  $RE = (y_i - y_i^*)/y_i$ , where  $y_i$  represents the results for the proposed double-flap wing sail and  $y_i^*$  the comparable results for the variable-camber, NACA0021 and arc sails.

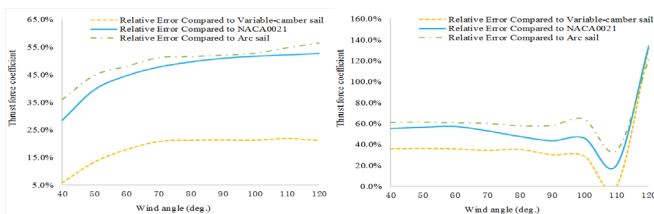

(a) Relative error in the thrust force coefficient (b) Relative error in the drift force coefficient

Fig. 15. Comparison of relative error for thrust and drift force coefficients

From the results of this comparison, we can see that our new type of wing sail is aerodynamically efficient and has a higher aspect ratio and performance, with a relatively small sail area. The two wing flaps increase the total area of the wing sail, and change the curvature of the airfoil, while the apparent angle between the wind and the whole wing sail can be changed and more force can be gained. There are small gaps between the three parts of the wing sail through which the wind can flow easily, and the wind velocity can be increased together with the air pressure decreased, giving a greater lifting force in a stable way.

## CONCLUSIONS

As a technology that has been already adopted on board ships for the purposes of energy saving and emission reduction, sail-assisted propulsion has made remarkable achievements in recent years. In this paper, a new collapsible wing sail with double flaps was proposed, and its aerodynamic performance was studied. The authors investigated the best configuration of parameters and analyzed the aerodynamic performance of the new wing sail using a numerical simulation method. The following results were obtained:

(1) A collapsible wing sail with double flaps was proposed. The maximum lift coefficient of the wing sail reached about 1.68 with the expansion of the two flaps.

(2) The proposed double-flap wing sail gives better performance than the variable-camber, NACA0021 and arc sails.

(3) In order to achieve high performance from the wing sail in most wind directions, it is necessary to consider the best configuration of the parameters for the wing sail.

(4) The thrust coefficient of the wing sail increased with the angle of attack, between 40° and 120°.

From the simulation results, it is clear that the use of our proposed wing sail can easily save energy in terms of ship propulsion, and in future work, we will focus on wind tunnel tests and development of a control system.

## ACKNOWLEDGMENTS

The authors wish to thank the National Natural Science Foundation of China (Grant No. 5150911) and the Natural Science Foundation of Jiangsu Province of China (Grant No. BK2012696) for financial support.

## REFERENCES

- Scupi A., Avital E. J., Dinu D., et al. (2015): *Large Eddy Simulation of Flows around a Kite Used as an Auxiliary Propulsion System*. Journal of Fluids Engineering, Vol. 137(10),1-8.
- Naaijen P., Koster V., Dallinga V.(2006): *On the Power Savings by an Auxiliary Kite Propulsion System*. International Shipbuilding Progress, Vol. 53(4), 255-279.
- Grosan N., Dinu D. (2010): *Considerations Regarding Kite Towed Ship's Manoeuvring*. Proceedings of the 3rd International Conference on Maritime and Naval Science and Engineering, 28-33, WSEAS, Constanta, Romania.
- Li Q., Nihei Y., Nakashima T., Ikeda Y. (2015): *A Study on the Performance of Cascade Hard Sails and Sail-Equipped Vessels*. Ocean Engineering, Vol. 98, 23-31.
- Bergeson L., Greenwald K.C. (1985): *Sail Assists Developments 1979-1985*. Journal of Wind Engineering and Industrial Aerodynamics, Vol. 19(1-3), 45-114.

6. Scott D. (1985): *Sail-Assist for Cargo Ships: Computer Controlled*. Popular Science, Vol. 226, 68(3).
7. Low H. T., Luo S. C., Winoto S. H. (1991): *Flow Past a Wind-assisted Ship Propulsion Device*. Ocean Engineering, Vol. 18(6), 555-565.
8. Ueno M., Tsujimoto M., Takekawa M., Fujita H., et al. (2005): *Fundamental Research for Development of an Advanced Sail-Assisted Ship*. IEEE Techno-Ocean '05, Vol. 2, 1102-1109.
9. Ouchi K., Uzawa K., Kanai A. (2011): *Huge Hard Wing Sails for the Propulsor of Next Generation Sailing Vessel*. The Second International Symposium on Marine Propulsors, Hamburg, Germany, June 2011 .
10. Ouchi K., Uzawa K., Kanai A., Katori M. (2013): "Wind Challenger": *The Next Generation Hybrid Sailing Vessel*. The Third International Symposium on Marine Propulsors, Launceston, Tasmania, Australia, May 2013, 562-567.
11. Burden A., Lloyd T., Mockler S., et al. (2010): *Concept Design of a Fast Sail Assisted Feeder Container Ship*. Main Report of Group Design Project, University of Southampton, School of Engineering Sciences, 58-59.
12. Lin Y.(2013): *Design and Research on a Flap-Wing Sail for a Wind-Assisted Vessel*. Master's thesis, Dalian Marine University, Dalian, China (in Chinese).
13. Guo S.(2012): *Optimized Design of a Wingsail and Study of Energy-Saving Applications for a Sail-Assisted Ship*. Master's thesis, Dalian Marine University, Dalian, China (in Chinese).

## CONTACT WITH THE AUTHORS

### **Dongqin Li**

*e-mail: mandy\_ldq@163.com*

School of Naval Architecture & Ocean Engineering,  
Jiangsu University of Science and Technology,  
NO.2 Mengxi Road, Jingkou District, 212003 Zhenjiang

**CHINA**

### **Yili Zhang**

*e-mail: 435356064@qq.com*

Jiangsu University of Science and Technology,  
NO.2 Mengxi Road, Jingkou District, 212003 Zhenjiang,

**CHINA**

### **Peng Li**

*e-mail: 596293695@qq.com*

Afilicja: Jiangsu University of Science and Technology,  
NO.2 Mengxi Road, Jingkou District, 212003 Zhenjiang,

**CHINA**

### **Jingjing Dai**

*e-mail: 270397934@qq.com*

Jiangsu University of Science and Technology,  
NO.2 Mengxi Road, Jingkou District, 212003 Zhenjiang,

**CHINA**

### **Guohuan Li**

*e-mail: 2272658340@qq.com*

Jiangsu University of Science and Technology,  
NO.2 Mengxi Road, Jingkou District, 212003 Zhenjiang,

**CHINA**