

SELECTED PROBLEMS OF EXPERIMENTAL TESTING MARINE STERN TUBE BEARINGS

Agnieszka Barszczewska

Ewa Piątkowska

Wojciech Litwin

Gdańsk University of Technology, Poland

ABSTRACT

This paper presents typical methods for conducting experimental tests on main shaft slide bearings. There are described their possible testing capabilities, advantages, drawbacks and limitations. Various testing methods were analyzed to find a solution able of providing a wide range of possible investigations at possibly acceptable limitations.

Keywords: marine bearings, polymer journal bearings, tribology, real scale test,

INTRODUCTION

Marine main shaft bearings, especially heavy loaded stern tube bearings constitute crucial subsystems in any ship propulsion system. Safety at sea depends on their durability and reliability [1]. From the very beginning of application of mechanical propulsion to ships, i.e. since over 150 years they have sometimes produced serious problems [2]. A failure of one of them may lead to catastrophic consequences resulting from breakdown of ship propulsion system. [3]. In the case of finding a defect in bearings docking the ship is necessary for disassembling the shaft line and carrying out repair or exchanging failed components.

The technological development which has occurred for the last decades made it possible to improve step by step shaft line subsystems. Novel bearing materials and seals as well as environment friendly lubricants have been worked out [4].

For many years in scientific and research centres worldwide have been carried out experimental investigations on bearings for ship main shafts, water turbines or pumps. Sometimes it turns out that obtained results appear incredible. This often results from imperfectness and

limitations of test stands or simply due to selection of an inappropriate test method.

During testing the slide bearings many very different parameters are measured. The resistance to motion determined in the form of friction coefficients is one of the crucial indices reflecting working conditions and energy losses in bearing, which lead to heat generation in friction zone. Measurements of bearing bush temperature are ones of those made most often. During testing the bearings which work in the regime of liquid friction hydrodynamic pressure in lubrication clearance as well as shaft axis orbits, i.e. its trajectories, are measured.

One of the main problems during carrying out experimental tests on slide bearings is the question of scale – that is how big in size a bearing subjected to testing should be to get credible results. The testing of bearings in real scale, i.e. that in which they work in a real object, would be most desired. This is often practically not possible because of a huge cost of such tests. For this reason an object to be tested is extended to a possible largest size in order to allow to install measuring instruments without exceeding assigned funds and taking into account capability of a laboratory infrastructure being at one's disposal.

PROBLEM

A test stand for slide bearings, if it has to be a source of credible measurements, should be similar as to its construction to a machine in which a given solution will be implemented. Hence in some countries the experimental objects (water power plants) have been developed for testing various novel solutions. It is a well known fact that bearings producers implementing some new solutions conclude agreements with ship owners to introduce new, experimentally not tested technologies into real objects. In case of an untimely failure they have to cover repair costs. However in practice it is very costly. Therefore various test stands are built. The most costly ones make it possible to test full scale bearings and their driving power exceeds 500 kW [5][6].

There are built usually test stands for testing the bearings for shafts of a diameter below 100 mm. It is very rare case that the stands are of a design which reflects features of a given application. This results from the fact that e.g. a stand for testing ship propeller shaft system consisted of a propeller

shaft and two bearings, though very expensive, has limited possibilities for conducting measurements. Hence in most cases there are built stands intended for testing a single bearing bush only.

REVIEW OF TYPICAL SOLUTIONS

A stand built in 2010 at Gdansk University of Technology for testing propeller shaft water-lubricated bearings makes it possible to test them in a system which has been earlier applied on a small fishing ship

(Fig. 1). It is consisted of the forward bearing housing (5) and stern tube aft bearing housing (3) of different lengths (that results from rules of classification institutions), the bearing bush coupling (9) which connects the bushes into a common unit together with propeller shaft tube and propeller shaft itself. Like in real conditions the shaft (1) is loaded by propeller weight represented here by the steel discs (10).

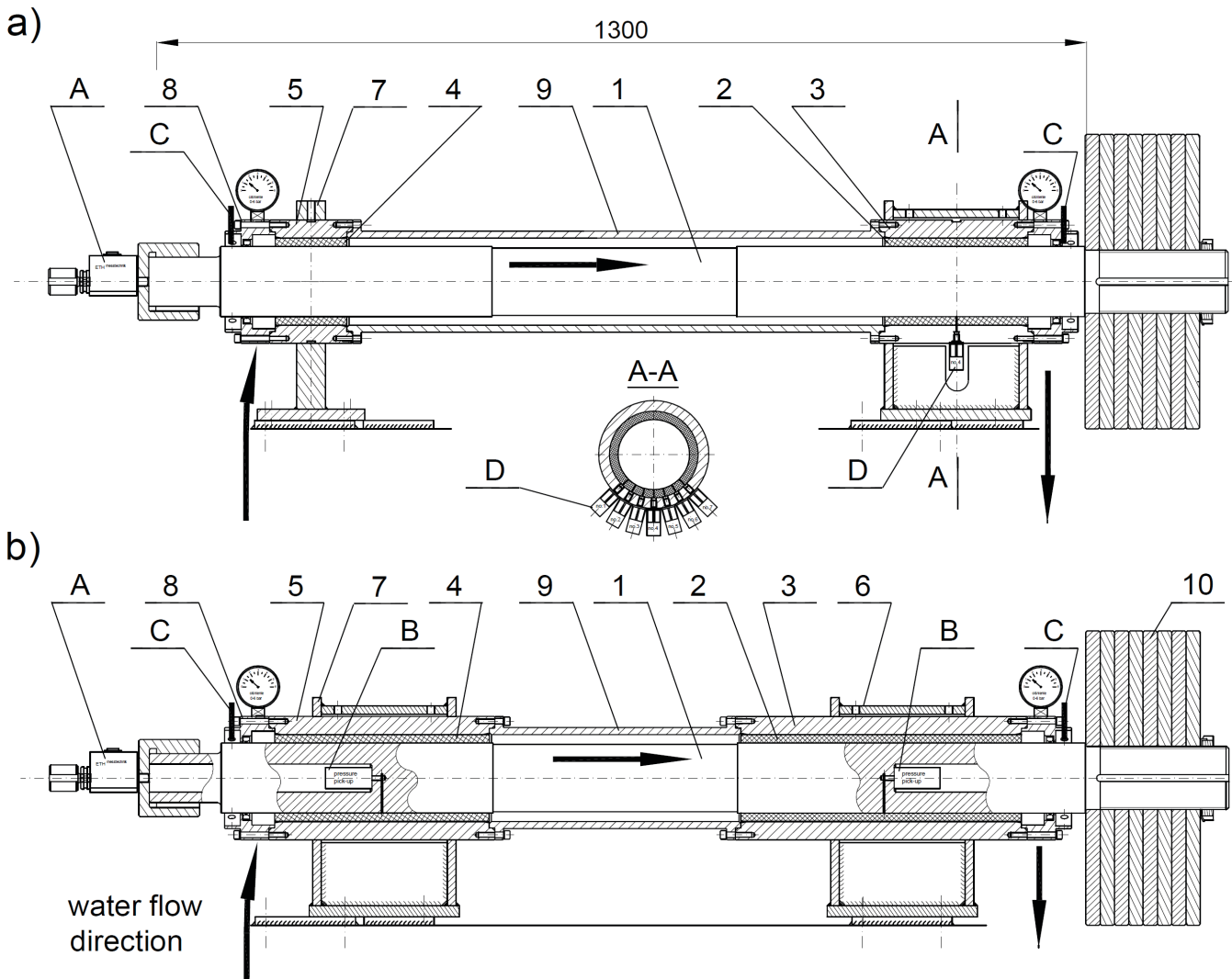

Fig. 1. Stand for testing propeller shaft unit - shown in two variants, 1 - main shaft, 2 - stern tube aft bearing, 3 - stern tube aft bearing housing, 4 - forward bearing, 5 - forward bearing housing, 6 - aft bearing support, 7 - forward bearing support, 8 - cover with seal, 9 - bearing bush coupling, 10 - loading steel discs - representing propeller weight

The described configuration of the test stand which corresponds to a real application, has some significant drawbacks and limitations. It can be stated that like on a real ship there certainly occurs a misalignment of both bearings against the shaft [7]. For identifying it a special measurement instrumentation should be used. Possible range of testing is also limited. Practically, it is not possible to measure resistance to motion in each of the bearings. The torque meter (A) allows to measure friction torque and calculate total friction coefficient for both bearings. In practice the quantity is not useful because of differences in radial load in both bearings as the forward bearing housing (5) is low loaded and the stern tube aft bearing housing (3) transfers most of radial load and in consequence it constitutes the

a tested slide bearing loaded by radial force is installed (Fig. 2) [10][11][12][13][14][15]. In some solutions the rolling bearings are installed close to each other and the tested bush is fixed on a pin protruding outside [16][11][17][18][19].

Such solution is commonly applied due to many advantages, as it is first of all a simple construction and provides a wide range of possible testing. There is good access to the tested bearing and measuring instruments can be installed on the tested bush. In such case, values of resistance to motion are usually recorded – by measuring friction torque, pressure in lubricating film – by sensors installed in bearing bush, shaft centre orbits – by using contactless sensors, as well as temperature in bushes.

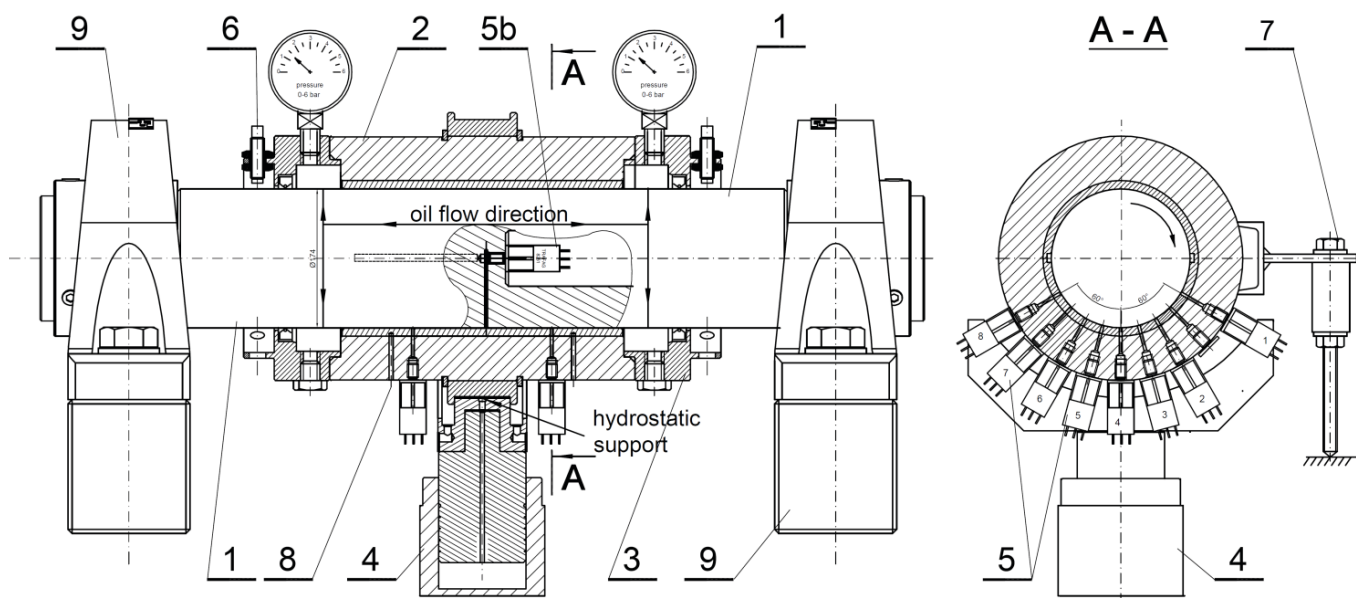

Fig. 2. Single bearing test stand (SBTS) developed in Gdansk University of Technology; 1- main shaft, 2- tested bushing unit, 3- covers with seals, 4 - load exertion system – hydraulic jack, 5- pressure sensors, 5b- pressure sensor in the shaft, 6- distance sensors, 7- friction force sensor, 8 - temperature sensors installed in the bushing sliding layer; 9 - supporting shaft roller bearings

weakest link of the propeller shaft bearing system. It fails most often in spite of that classification societies require to select a minimum length of bushes equal to two up to four diameters (depending on a used material) in order to reduce mean pressure to occur in the bearing.

During the testing of the propeller shaft unit pressure values in lubricating film of stern tube bearing were additionally recorded by means of the pressure sensors placed in the bush, (D), as well as in the shaft, (B). They allowed to confirm hydrodynamic phenomena occurring in the bearing [8][9]. And, measurements of shaft axis trajectories were also conducted by using the contactless distance sensors (C).

During the tests it turned out that to apply greater radial loads in the form of hung weight is difficult. Therefore the shaft loading system was tested with the use of an additional pneumatic actuator. As results from the literature sources the so designed testing system is used very rarely. In most cases only single bearings are tested. The most frequently used solution is supporting the shaft by means of two rolling bearings between which

MEASUREMENT PROBLEMS

Unfortunately, any of the methods used for testing slide bearings has some limitations and drawbacks. Hence, a specific type of test stand should be selected for given purposes.

MEASUREMENTS OF RESISTANCE TO MOTION

Resistance-to-motion measurements make it possible to draw Stribeck curve which describes friction coefficient in function of rotational or sliding speed. On a typical diagram, zones of boundary, mixed and fluid friction can be identified. In case of experimental investigations friction torque is usually measured and on its basis friction coefficient is calculated. As much as such measurements can be performed enough precisely when a bearing operates in the boundary friction zone, i.e. when resistance to motion is rather large, a problem arises with its small values which appear e.g. in testing the bearings lubricated with liquids of a low viscosity. Friction

coefficient may then reach a value of about 0.001 and this is the case when measurement accuracy should be particularly considered. First of all, hardly ever resistance to motion of a single bearing can be successfully measured, hence total resistance covering also drag in sealing is usually measured (Fig. 1 and 2); additionally, the lubricant supply pipes to the bearing unit and possible additional instruments cause the conducting of a precise measurement difficult.

However it seems that for practical reasons it is not necessary to reach an ideal precision. Practitioners are usually interested in information about when a given bearing passes to work in the desired regime of fluid friction as well as how big margin of hydrodynamic capacity is left. Therefore even the Stribeck curve diagram loaded with a certain inaccuracy is deemed useful. Worth adding, that it is often difficult to perform precise measurements in the phase of transition from the mixed to fluid friction. Usually, the test stand driving system has some limitations and in such transition phase to keep a constantly low rotational speed is difficult. This is necessary if the researchers want to obtain a possibly accurate diagram of Stribeck curve precisely showing the instance of transition from mixed to fluid friction (Fig. 3). For this reason during the investigations carried out at Gdansk University of Technology a special two-gear drive unit intended for keeping a selected constant speed within the whole range of speed from 0 up to 11 rps was applied (Fig. 3).

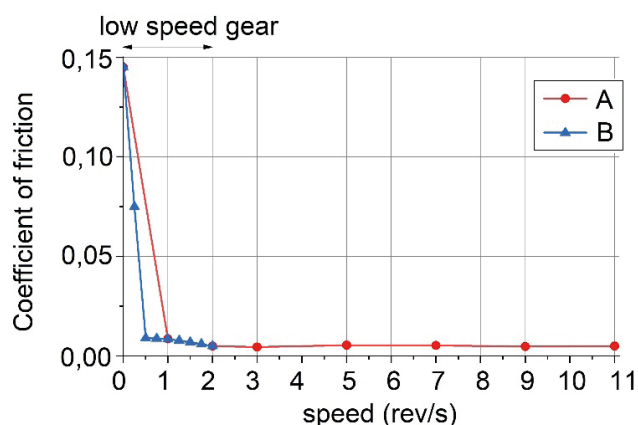

Fig. 3. Friction coefficient values calculated on the basis of resistance to motion measured at the SBTS stand for water-lubricated bearings with polymer bush; A- characteristics for typical measurement points, B- for thickened spacing of measurements points at two-gear drive system operation – with indicated the thickened spacing area of measurements in the phase of transition from mixed friction to fluid friction

It's worth paying attention to the fact that the experimentally obtained friction coefficient characteristics differ from the theoretical ones. According to these authors' opinion it results a.o. from the fact that the diagram presents the deformed bearing friction characteristics, usually enlarged by drag in sealing system and lubricant supply pipes, etc.

Making an attempt to describe problems of measuring the resistance to motion, the question should not be omitted of exerting radial load onto a tested bearing and its impact on friction torque recorded during testing. The commonly

applied method of exerting load onto bearing bush by means of rolls introduces another significant measurement error which is difficult to assess, and has a special effect on very low values of resistance to motion during the fluid friction working phase. Therefore it seems necessary to apply a contactless load exertion system based on electromagnetic field (passive or active magnetic bearing) or hydrostatic lubricating film. Such method is applied a. o. to the SBTS stands of Gdansk University of Technology (Fig. 2), and other ones as well [20].

MEASUREMENT OF PRESSURE IN LUBRICATION CLEARANCE

Pressure measurement in lubrication clearance makes it possible to test experimentally a bearing in respect of hydrodynamic and hydrostatic phenomena which occur in lubrication clearance. In practice two measurement methods are used, however both of them have some limitations. Sensors for measuring fast-varying pressure can be installed either in the bush (that is rather often applied) or in the rotating shaft (Fig. 2). In both the cases it's worth paying attention to the fact that recorded pressure values are measured in a very thin lubricating film even a few micrometers thick only. When a measurement hole in wall of the bush or shaft is of 1mm diameter only, even then it must have a negative effect on measurement accuracy as it causes a perturbation in lubricant flow. Another problem results from constructional limitations as only in a very rare case it is possible to place pressure sensor close to very surface of shaft or bush. Usually, the sensor is connected through a fine hole therefore never it can be sure that the system is not airlocked and the possible left air does not dump pressure signal under pressure. Moreover, if the hole is made in the shaft then the centrifugal force will act on the liquid column in its interior and this fact should be taken into account in processing results of measurements.

The measurements carried out by pressure sensors placed in the bush allow to monitor pressure changes in lubricating film. This is a typical phenomenon for every bearing working in the fluid friction regime. As results from that, the fluid friction process is a very complex phenomenon as a load-carrying lubricating film occurs in response to an externally exerted load. For this reason the shaft axis circles – round a repeatable trajectory, called usually orbit, within the bush. On its size an instantaneous thickness of lubricating film, hence also dynamic pressure changes in the film, depend. However, such approach is rather limited by that the sensors, in view of their size, cannot be placed close to each other, that would be especially desired in the area of a rapid drop of pressure when cavitation appears. For this reason the research authors usually present the diagrams of mean pressure in lubricating film, based on measurements conducted by using a few sensors placed in the bush (Fig. 4).

In contrast, a sensor placed in the shaft can record pressure distribution run with a given frequency and thus it is possible to make a precise measurement during one full rotation of the shaft. However, the problem consists in that the recorded values of pressure in lubricating film are instantaneous.

If the shaft centre orbit is little and amounts to a few or a dozen or so micrometers only then pressure pulses are small and the involved measurement error is acceptable. However, the installation of a sensor in the shaft provides a unique advantage – it is possible to conduct pressure field measurements by shifting step by step the bush over the sensor along an appropriately elongated shaft. Such method was applied during testing the bearing of modified geometry in which both hydrostatic and hydrodynamic phenomena occurred simultaneously (Fig. 5).

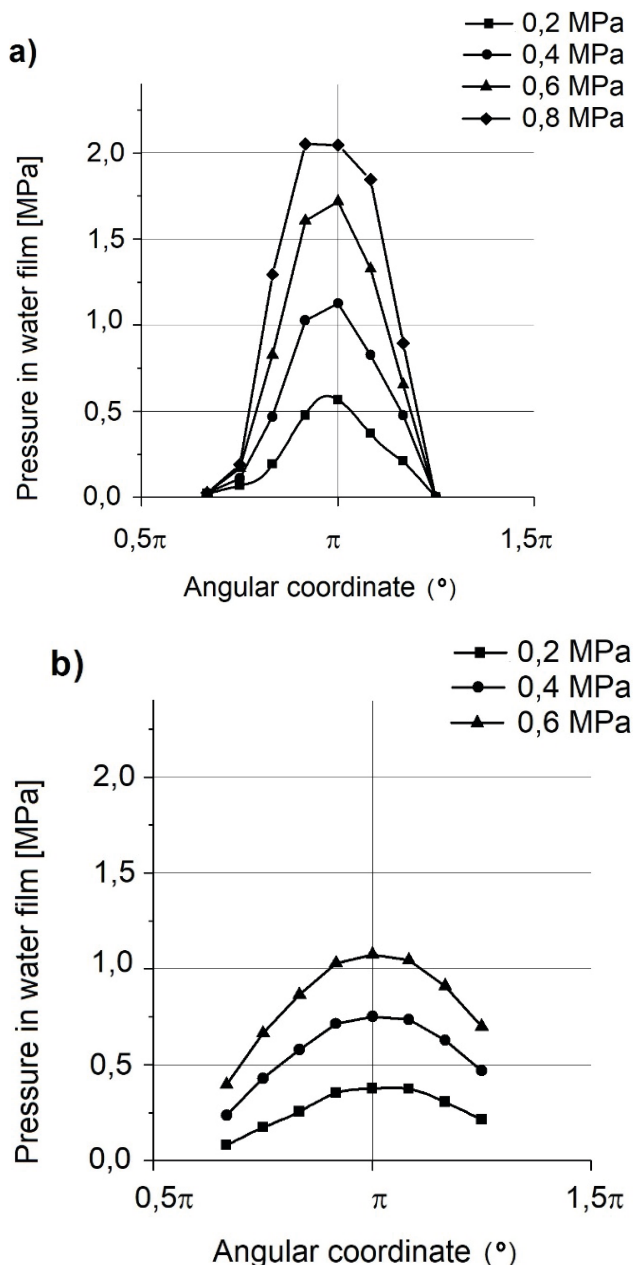

Fig. 4. Hydrodynamic pressure distribution in the water-lubricated bearings for different mean pressure values ranging from 0,2 to 0,8 MPa; a) the stiff bush made of PTFE, b) the elastic rubber bush – NBR

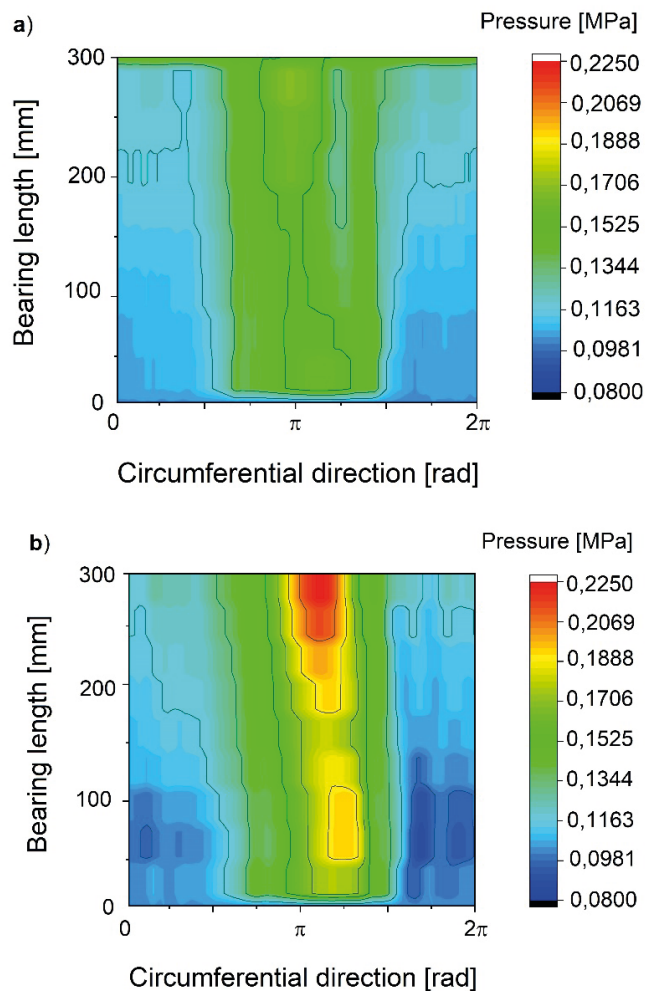

Fig. 5. Hydrostatic pressure distribution (a), and both hydrostatic and hydrodynamic pressure distribution (b) in lubricating film, the measurements conducted by using the pressure sensor installed in the shaft

MEASUREMENTS OF SHAFT AXIS TRAJECTORY

For many years contactless eddy current sensors have been used in rotary machinery diagnostics. They make it possible to perform contactless measurements of a distance between the housing and rotating shaft with a very high accuracy. If a pair of sensors making measurements along two axes, usually vertical and horizontal, are installed, then to draw a shaft orbit is possible. (Fig. 6). Results of such operation are a very valuable source of information on bearing features. If extreme positions of the shaft journal in the bush are experimentally determined, which is usually made at still standing machine and in consequence a contact between the shaft journal and the bush is reached, then it will be possible to localize position of the so called circle of clearance (Fig. 6A). The trajectory located within clearance circle allows to assess a real instantaneous thickness of lubricating film. In the below presented case (Fig. 6A) in the mineral oil lubricated bearing with white metal bush the film thickness amounts to about $10\ \mu\text{m}$, whereas the orbit size reaches about $50\ \mu\text{m}$. In such

case it is hard to speak about any margin of its hydrodynamic load-carrying capacity.

For the water-lubricated bearings with polymer bushes there is possible to draw a real contact zone between shaft and bush (clearance circle), that allows to identify errors in bush geometry (Fig. 6B). Such errors usually result from bush machining, assemblage of bushing and material expansion resulting from water absorption by polymer. The deformed sliding pair geometry, elastic bush deformation and low viscosity of the lubricant (water) cause that to assess thickness of very thin lubricating films is not possible. Therefore justified doubts may be raised as to the working conditions of the bearing. In such case the remaining measurements – of resistance to motion and pressure field – become helpful.

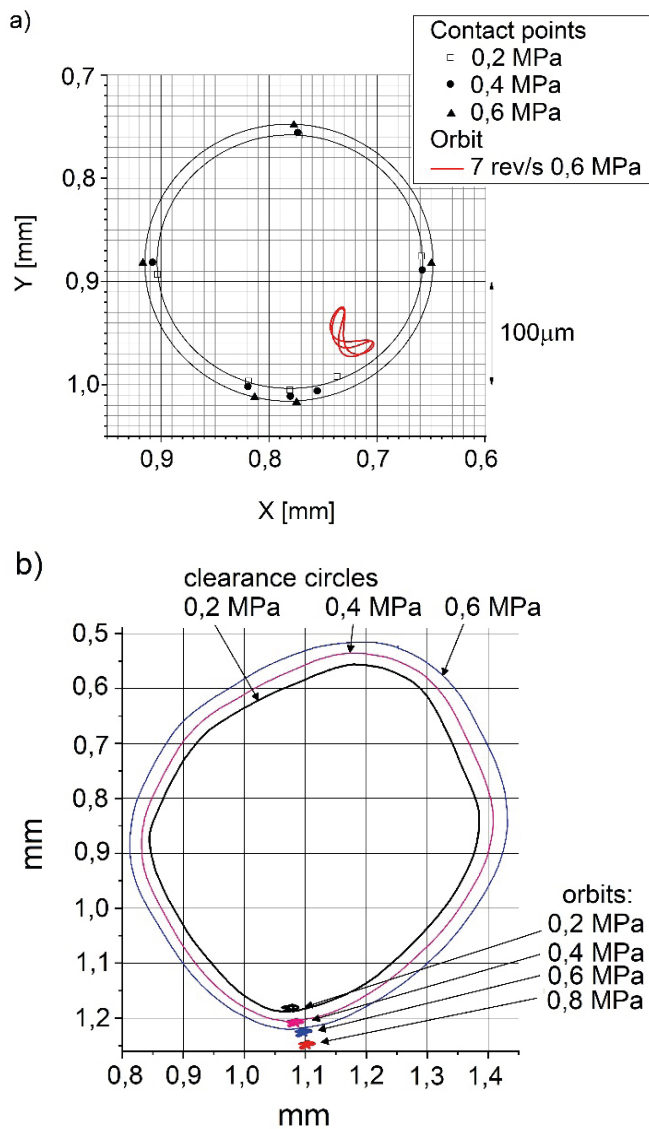

Fig. 6. Shaft centre orbits and experimentally recorded clearance circles; A – oil-lubricated bearing, clearance circles verified by contact points; B – water-lubricated bearing – shaft centre orbits and deformed real clearance circles

MEASUREMENTS OF TEMPERATURE IN POLYMER BUSHES

Temperature is one of the crucial diagnostic parameters of bearing performance. If in bearing operation an excessive increase of pressure happens it may demonstrate that a failure approaches. The most frequent cause of overheating the bearing with polymer bush results from its insufficient cooling by lubricant supplied to friction zone. This may occur e.g. as a result of gradual clogging up the filter. What's worse, together with temperature rise the bearing clearance drops due to thermal expansion and consequently flow drag increases. For this reason the temperature rise process usually develops very violently. Character of wear of polymer bushes may be different from that of bushes with white metal slide layer [21][22]. In extreme cases the bush melting or its jamming on the shaft may happen [23][24], which leads to rapid stopping the machine (Fig.7).



Fig. 7. The bush melt in laboratory conditions, shaft diameter: 100 mm, bush material: elastomer

Formerly, to observe changes in bearing operational conditions, temperature of the oil flowing out from the bearing unit has been measured. In view of a low sensitivity to reactions occurring inside the bearing and their fastness, such measurement was supplemented with the measurement of bush temperature in an area of hydrodynamic lubricating film where temperature is high [25][26].

A direct measurement of temperature in lubricating film is practically impossible because of a high elasticity of polymer bushes and a possible failure of a sensor or shaft sliding inside the bush. Hence, temperature in polymer bushes is measured by using sensors placed no more than a few millimeters under sliding surface [27][28].

In many research centres a thermocouple is the most often used up to now sensor for measuring temperature in lubricating film as well as on sliding surfaces [6][29][6][30][31][32]. An unquestionable merit of a thermocouple compared with a resistance gauge [33] is its rather small size – its diameter can be as small as 0,1 mm, a low time of response to rapid temperature changes, assembling easiness and low purchase cost. Unfortunately, the application of

thermocouples for measuring the temperature in bearing with polymer bush has important limitations.

As it is known, the measurement of lubricating film temperature in a bearing with metal sliding surface where thermocouple and sliding surface are faced to each other [34][35] is loaded by a rather small error. Flowing oil heat permeates to the sensor through the measuring tip but is also transferred to the remaining part of the sensor through the surrounding bush material which becomes heated relatively fast due to its high thermal conductivity.

According to S. B. Glavatskih investigations, if the thermocouple is placed a few millimeters under babbitt sliding layer and the hole where the thermocouple has been placed is flooded by flowing warm oil, then indications of the thermocouples will be close to those obtained from the thermocouples facing with sliding surface. However it turns out that, if the PTFE material is used for sliding layer, indications of the thermocouples are much lower than a real oil temperature [36]. The difference results from a low value of heat conductivity of PTFE sliding layer which effectively isolates the neighbourhood of the measuring sensor from heat source.

An additional limitation in applying the thermocouples to temperature measurement in polymer bushes is that the thermocouples placed in steel housing carry off heat from the measuring tip to the environment through their cases. It is deemed that to eliminate completely this effect the thermocouple should be immersed in the medium up to the depth ten times greater than its diameter; it means that a thermocouple of 1 mm diameter would be immersed 10 mm deep [37]. In the case of measuring temperature in lubricating film or in polymer bush of a high heat transfer resistance to make such measurement is not possible. In the case of bearings with metal sliding layer the effect of heat carrying-off from measurement point through thermocouple is negligibly small because of rather similar values of heat conductivity coefficients of bearing material

and thermocouple. Unfortunately, in case of temperature measurements in polymer bush the heat carrying-off effect additionally reduces thermocouple indications in view of a much greater heat conductivity of thermocouple steel case compared with that of polymer material.

Irrespective of a kind and location of temperature sensor, the error of temperature measurements in polymer surfaces, which results from polymer insulating properties, will be always greater than in the case of temperature measurements in metal surfaces.

The tests performed with a bearing of 100 mm diameter, fitted with elastomer bush showed that the bearing which operates under 0,2 MPa pressure and a lack of flow of lubricant, suffered a failure at 30°C flowing water temperature (measured before and behind the bearing) and 27°C temperature measured 3 mm deep below sliding surface. The bearing producer informs that 60°C temperature is the ultimate one for the bearing working in wet conditions. The test results presented in Fig. 7 clearly show that this temperature was exceeded and consequently the error of its measurement was high.

In order to recognize the problem of heat transfer through polymer bush, an examination of temperature distribution in the bush was performed in its steady state (Fig. 8). To this end, 4 thermocouples were radially placed and 4 ones – along bush axis (Fig. 8), at different distances from bush sliding surface (namely : 3, 6, 9 mm and in the water). During temperature measurements, when temperature of water inside the bush was kept constant, it was observed that indications of all radially placed thermocouples were lower by 15°C than those of thermocouples placed along the bush axis.

Moreover, the indications of the thermocouple radially located 3 mm deep below sliding surface (i.e. like in the tests during which a failure in polymer bush happened) were by 20°C lower than the temperature of water (100°C). The estimated amount of heat transferred through bush walls was abt. 50 W.

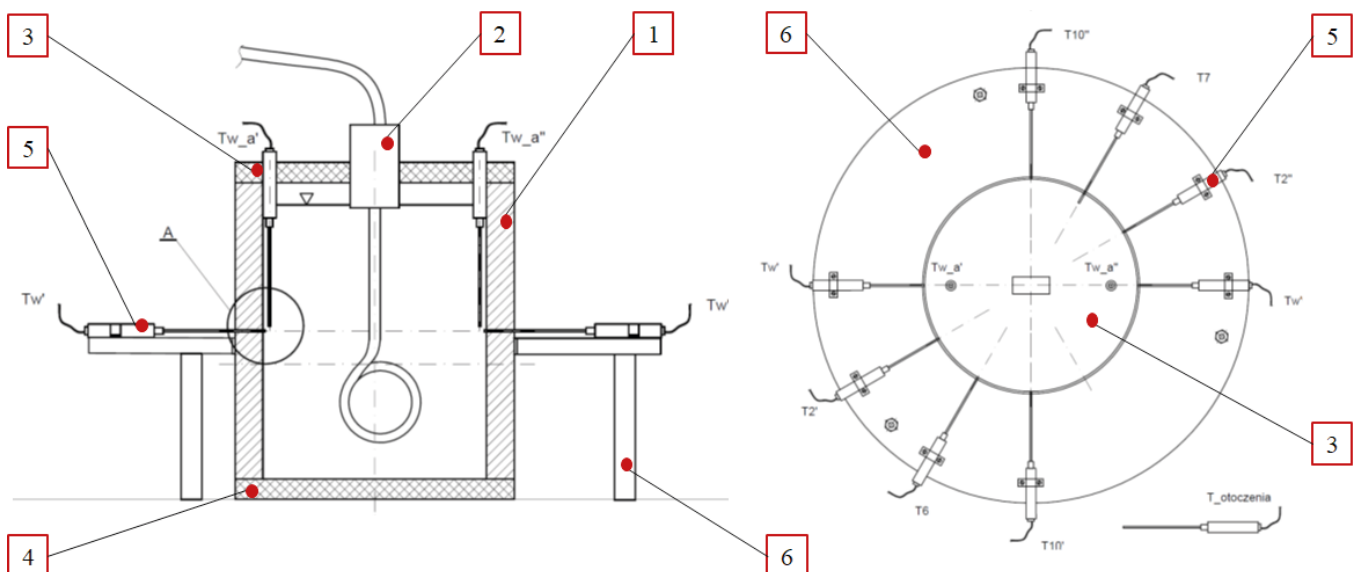

Fig. 8. Test stand for examining heat exchange through bush wall; 1 – tested bush, 2 – electric heater of 300 W power, 3 – cover (PMMA), 4 – bottom (PMMA), 5 – thermocouples K \varnothing 1 mm, 6 – sensor support

As results from the performed investigations, temperature measurements in polymer bushes will be always loaded by a large error, especially when thermocouples fitted with steel case are used. The error can be lowered by:

- application of thermocouples of a smaller diameter (lower heat losses),
- application of thermocouples with uncovered measuring tips (exposed junction) and remaining parts covered with insulation of a low heat conductivity.

TESTS OF BEARINGS LUBRICATED WITH CONTAMINATED LIQUIDS

In practice, many different additives are applied to improve properties of lubricants. Experimental tests showed that certain nanoparticles (metal oxides, metals, sulphides, rare chemical compounds, carbon, nanocomposites etc) are capable of improving tribological properties of oil-lubricated sliding pairs [38].

Apart from the desired additives which positively affect plastic-metal sliding pair, some undesired additives can be present in the form of contaminations – solid particles, usually. They appear during operation or standstill of machines and the following ones may be numbered among them: e.g. wear products from machine elements co-working in sliding as well as particles which fell by chance into lubricant or also those coming from outside, such as pulver, dust or sand. The contaminations, causing an increase in sliding pair friction, negatively affect performance and life of machines. The solid particles which fell into the system cause an excessive and premature wear and in consequence service standstills necessary to repair or replace failed elements.

Sliding pairs are the places where a greater operational durability is required for co-working elements of machines and devices, such as e.g. shaft journal and bush. Both the elements are to be mutually well-matched. The shaft external layer is to have a proper chemical content, hardness and roughness because post machining traces are always left on its surface – they are called surface topography (usually visible in the form of circumferential grooves) ; a possible influence of constructor on it is rather limited.

The considerations of the effects of contaminations in the form of solid particles on wear of shaft journal and bearing bush were presented in detail in the publication [39] where conclusions were drawn from the so far made experiments concerning the relation between size and occurrence frequency of solid particles and lubricating film thickness and their common effect onto wear process [40][41].

The first research work concerning effects of contaminations on machine performance, probably done in 1927, proved that presence of solid contaminations resulted in an increase of friction. Several researchers showed that for determining degree of wear the ratio between size of contamination particles and minimum thickness of lubricating film is of a great importance. If the ratio is greater than 1, the wear is high, and it takes its largest value when the ratio is equal to 1. Another tests concerned concentration of contaminations

– the higher the concentration the greater friction and wear. In the subsequent work, effects of shape and hardness of solid contaminations on bearing performance were considered; it was concluded that the ratio between shaft hardness and bush hardness taking value from 3 to 4 leads to the largest wear. Effects of roughness in contaminated bearings were also examined – surfaces of a initially high roughness (if only the contamination particles are small) cause a low wear. Also, the bush surface wearing-in effect was observed when the particles are very small and motion speeds – very high. An explanation was also obtained as to the role of motion velocity of the particles and their sedimentation on bearing surface. During further research a relationship dealing with bearing surface hardness was established. As a result, limits for the ratio between hardness of journal, bush and contamination particles, leading to a minimum wear, were suggested. Also, the effect of solid contaminations on seizing temperature was considered with taking into account different features of solid particles.

Results of the so far performed investigations may be helpful in the selecting of proper materials for shafts, bearings, size of particles to be tested, as well as working parameters. To this end, various test stands were developed for carrying out experiments on appropriateness of application of filters for measuring contamination level and matching oil film thickness in sliding pair [39], as a result, experimental strategies were proposed for testing the role of various additives in limiting degree of bearing wear and temperature rise and in forming minimum oil layer thickness in a lubricating contact. The effect of surface texture on operational characteristics and life of journal bearings working in a contaminated lubrication system was also investigated [42]; to this end, experimental tests were performed on smooth and textural surfaces of bearings operating under different loads and with different speeds; for the tests lubrication circumference was so modified as to allow for controlling injection of a contaminated mixture (oil / Al oxide pulver) into the main oil flux. In the subject – matter literature can be found research results focused on size and hardness of solid particles, lubricating film thickness as well as crack propagation [43]. The removing from oil (filtering-off) the contamination particles greater than minimum thickness of hydrodynamic layer was suggested. The solid particles getting in between shaft journal and bearing bush are “hammered” into a more soft material of the bush and act as a cutting tool impairing shaft journal surface and leading this way to its failure.

The subsequent wear tests were performed with the use of the tribotesters such as: the “cylinder on disc” [44][45] [46], “pin on disc” [47][48], “block on ring” [49] and “ball on disc” [50]. During the tests the following quantities were measured a. o.: the friction coefficient at different sliding speeds, lubricating film thickness, radial wear of material, loss of journal mass, surface morphology of used elements as well as a change in surface roughness. All the tests were carried out for different working parameters.

The considerations and experimental tests concerning the effect of solid particles on friction and wear in oil lubricated

machinery have been rather comprehensively described in the literature, however, only a relatively scarce scope of information on application of such lubricant as water, can be found there.

In some simple intight solutions where a working liquid such as sea or river water serves as lubricating medium, wear process is greatly affected by amount and kind of particles. For instance, the Baltic Sea has been thoroughly examined as to the concentration and size of solid particles present in its waters [51]; also water salinity, temperature and turbidity were measured in different seasons [52], mineral and geochemical variability of surface sediments was reported [53], also there were determined transport paths of sediment materials in the form of kaolinite and chlorite coming from estuaries of rivers of southern and eastern drainage basins of the Baltic Sea and from the North Sea through Danish straits, which lead towards deposit basins of the Baltic Sea [54], as well as effects of various factors on concentration and spatial distribution of the sediments brought by rivers to the sea [55].

Water contaminations in the form of sand greatly impacts tribological features of friction pairs (stainless steel – plastic) of ship shaft line stern tube bearings. For examining the phenomenon the pin- on- disc tribotesters were used [56] [57][58].

During the measurements different particle sizes were taken into consideration at varying working parameters. The tests were conducted for the particles size ranging from 53 to 106 μm and their concentration of 0%, 1%, 2%, 4% and 6% ratio in 3 l water container, under different loads of 8 N, 17,5 N, 26 N, 36,5 N and 46 N as well as sliding speed values of 0,393 m/s, 0,767 m/s, 1,158 m/s and 1,557 m/s. From the experimental tests were drawn the conclusions that the friction coefficient and mass loss are decreasing along with sliding speed and load increasing, while they are decreasing along with contamination level increasing.

A more intensive wear of shaft journal and bearing bush operating in unfavourable working conditions such as contaminated liquids is determined by the following factors : sliding speed, quantity of exerted load, contamination concentration as well as different size of sand grains [58]. The tests showed that along with increasing the parameters also friction coefficient increases due to the damaging effect of surface roughness and sand grains onto water film.

The above presented methods may serve as a basis for the suitable selecting optimal (most favourable) working parameters for sliding pairs of ship shaft lines at unfavourable operational conditions in order to assure this way safe and reliable performance of their water-lubricated bearings.

As results from an analysis of literature sources, none determined method exist for testing the bearings lubricated with liquids containing solid particles. Most of the published investigations was carried out with the use of tribotesters that may produce measurement results not representing real objects.

In the Laboratory of Marine Machinery and Systems, Gdansk University of Technology, there was developed a test stand which make it possible to test slide bearings lubricated

with water containing contaminations in the form of solid particles (sand), undesired in real working conditions. For such tests a way of inserting contaminations to the bearing, of mixing the liquid, as well as a quantity (weight/volume) and size of particles are of a great importance. The particles may be inserted directly to the bearing or the contaminated liquid can be only churned up and this way not all the particles will come in between bearing bush and shaft journal. An unquestionable effect on wear process of elements under friction is associated with quantity of exerted load and sliding speed as well. The recently made tests (to be published soon) have showed that the water containing particles inserted directly to the bearing intensifies the wear process in the bush and journal. The tests with the same sliding pairs but immersed in the mixture of the same concentration showed that the wear process was much slower, which undoubtedly is associated with another way of water inserting.

DISCUSSION

It's worth paying attention to the fact that in many articles are published results of tribological tests recorded by means of tribotesters, i.e. with the use of the test stands intended for testing resistance to motion and wear process on small specimens [59] [60] [61] [62] [63] [64] [65] [66] [67] [68]. However in this case contact geometry is different from that typical for slide bearing, e.g. the pin- on- disc contact. Such tests usually allow to perform only a comparative analysis of tested sliding pairs. In some cases such tests may be also aimed at identification of dynamic features of a bearing [69].

The tests carried out on greater stands, where real objects are tested, are undoubtedly more expensive but they allow – in spite of the described limitations – to bring working conditions closer to those occurring in real applications.

Technological development allows to create more and more perfect testing stand solutions. A very interesting concept close – for many reasons – to an ideal is the stand for testing a single bearing, in which, instead of supporting roll bearings, active magnetic bearings are used [70], [71], [72]. Owing to that, it is possible to fluently exert a load coming from the two-sided support and, additionally, to set a skew position which usually has a destructive effect on slide bearing and practically always happens in spite of the measures to reduce it to a minimum regardless the costs.

The question of similarity between a real system and test stand has been already discussed many times. It's worth adding that there is another reason why a stand differs from a real system. This is the question of heat exchange with the environment. On a ship, in water pump or water turbine the surrounding environment, i.e. water has usually a lower temperature than that in which laboratory tests are carried out. Moreover, different are also heat exchange conditions. Therefore it is worth directing attention to this fact when conducting the research focused on thermal questions, e. g. overheating the bearings in limited lubrication conditions. Only in some cases a tested object was immersed in water,

that obviously to a great extent complicated construction of the test stand, making carrying out the tests more difficult and providing considerable difficulties in installation design process and functioning of measurement instruments [73].

CONCLUSIONS

The development of modern sliding materials, more and more restrictive requirements for objects designed for purposes of shipbuilding, off-shore engineering or power industry result in that the question of a proper selection and design of bearing systems is more and more often discerned. New legal limitations associated with environmental protection, which force limitations in applying mineral oils, result in that novel lubricants based on water or vegetable oils are experimentally searched for. However, responsibility of producers of such lubricants is high because to predict consequences of a failure in bearing system may be difficult. For this reason the demand on performing experimental tests increases to a great extent.

It's worth adding that, since names of products should not be referred to in scientific publications, the producers more and more willingly agree to make their materials available for testing and more and more willingly give approval to use them for comparative tests and publish their results. It makes it possible to objectively compare properties of various materials. Owing to that, the producers have opportunity of getting knowledge on merits and drawbacks of their products, that undoubtedly encourages for developing their products. It's worth adding, that complex experimental tests on tribological properties allow to determine to which objects given specific solutions are applicable the most, and where they should not be used at all. For instance the tests carried out in the past proved that the materials most suitable for main shaft bearings did not perform well when applied to rudder bearings or water turbine guide apparatuses.

ACKNOWLEDGEMENTS

This work was a part of the research grant No. 2016/23/B/ST8/03104 entitled "Research on water lubricated sliding couples in improper lubrication conditions" financed by the Polish National Science Centre.

BIBLIOGRAPHY

1. R. Orndorff: *Water lubricated rubber bearings, history and new developments*, Nav Eng J, 1985, pp. 39–52,.
2. H. Hirani and M. Verma: *Tribological study of elastomeric bearings for marine propeller shaft system*, Tribol. Int., vol. 42, 2009, No. 2, pp. 378–390.
3. W. Litwin and C. Dymarski: *Experimental research on water-lubricated marine stern tube bearings in conditions of improper lubrication and cooling causing rapid bush wear*, Tribol. Int., vol. 95, 2016, pp. 449–455,.
4. W. Litwin : *Properties comparison of rubber and three layer PTFE-NBR-bronze water lubricated bearings with lubricating grooves along entire bush circumference based on experimental tests*, Tribol. Int., vol. 90, 2015, pp. 404–411.
5. B. J. Blair: *Getting the most from your bearings*. World Pumps, vol. 2016, No. 7–8, pp. 36–40,.
6. M. Wodtke and M. Wasilczuk: *Evaluation of apparent Young's modulus of the composite polymer layers used as sliding surfaces in hydrodynamic thrust bearings*, Tribol. Int., vol. 97, 2016, pp. 244–252.
7. W. Litwin, A. Olszewski, and M. Wodtke: *Influence of Shaft Misalignment on Water Lubricated Turbine Sliding Bearings with Various Bush Modules of Elasticity*. Key Eng. Mater., vol. 490, 2011, pp. 128–134,
8. W. Litwin: *Water lubricated marine stern tube bearings – Attempt at estimating hydrodynamic capacity,* in Proceedings of the ASME/STLE International Joint Tribology Conference 2009, IJTC2009, 2010.
9. W. Litwin: *Influence of local bush wear on water lubricated sliding bearing load carrying capacity*. Tribol. Int., vol. 103, 2016.
10. Q. Hongling, Z. Xincong, X. Chuntao, W. Hao, and L. Zhenglin: *Tribological Performance of a Polymer Blend of NBR Used for Stern Bearings*, 2012, pp. 133–139,.
11. Y. Wang, X. Shi, and L. Zhang: *Experimental and numerical study on water-lubricated rubber bearings*, Ind. Lubr. Tribol. Exp., vol. 2, 2014, no. 51175275, pp. 282–288,.
12. M. Del Din and E. Kassfeldt: *Wear characteristics with mixed lubrication conditions in a full scale journal bearing*, Wear, vol. 232, 1999, no. 2, pp. 192–198,
13. D. L. Cabrera, N. H. Woolley, D. R. Allanson, and Y. D Tridimas: *Film pressure distribution in water-lubricated rubber journal bearings*, Proc. Inst. Mech. Eng. Part J J. Eng. Tribol., vol. 219, 2005, no. 2, pp. 125–132,
14. Y. Zhimin et al.: *Study on tribological and vibration performance of a new UHMWPE/graphite/NBR water lubricated bearing material*, Wear, vol. 332–333, 2015, pp. 872–878.
15. R. Colsher, I. Anwar, J. Dunfee, and M. Kandler: *Development of Water Lubricated Bearing for Steam Turbine Application*, J. Lubr. Technol., vol. 105, 1983, no. 3, p. 318.

16. G. Gao, Z. Yin, D. Jiang, and X. Zhang: *Numerical analysis of plain journal bearing under hydrodynamic lubrication by water*, Tribol. Int., vol. 75, 2014, pp. 31–38.
17. A.-F. Cristea, J. Bouyer, M. Fillon, and M. D. Pascovici: *Transient Pressure and Temperature Field Measurements of a Lightly Loaded Circumferential Groove Journal Bearing*, Tribol. Trans., vol. 54, 2011, no. 5, pp. 806–823.
18. R. Gawarkiewicz and M. Wasilczuk: *Wear measurements of self-lubricating bearing materials in small oscillatory movement*, Wear, vol. 263, 2007, no. 1–6 SPEC. ISS., pp. 458–462.
19. A. Olszewski, M. Wodtke, and P. Hryniewicz: *Experimental Investigation of Prototype Water-Lubricated Compliant Foil Bearings*, Key Eng. Mater., vol. 490, 2011, pp. 97–105.
20. M. Wodtke, A. Schubert, M. Fillon, M. Wasilczuk, and P. Pajaczkowski: *Large hydrodynamic thrust bearing: Comparison of the calculations and measurements*, Proc. Inst. Mech. Eng. Part J J. Eng. Tribol., vol. 228, 2014, no. 9, pp. 974–983.
21. M. Mehdizadeh and F. Khodabakhshi: *An investigation into failure analysis of interfering part of a steam turbine journal bearing*, Case Stud. Eng. Fail. Anal., vol. 2, 2014, no. 2, pp. 61–68.
22. W. Wieleba: *The Mechanism of Tribological Wear of Thermoplastic Materials*, Arch. Civ. Mech. Eng., Vol. VII, 2007, No. 4.
23. J. Takabi and M. M. Khonsari: *On the thermally-induced seizure in bearings: A review*, Tribol. Int., vol. 91, 2015, pp. 118–130.
24. Q. Wang : *Seizure failure of journal-bearing conformal contacts*, Wear, vol. 210, 1997, no. 1–2, pp. 8–16.
25. D. Garner, A. L.-P. of the 13th, and undefined 1984, *Temperature measurements in fluid film bearings*, oaktrust.library.tamu.edu.
26. P. De Choudhury and E. W. Barth: *A Comparison of Film Temperatures and Oil Discharge Temperature for a Tilting-Pad Journal Bearing*, J. Tribol., vol. 103, 1981, no. 1, p. 115.
27. S. Strzelecki, Z. S.- Tribologia, and undefined 2011, *Operating temperatures of the bearing system of grinder spindle*, t.tribologia.eu.
28. D. G. Lee and S. S. Kim: *Failure analysis of asbestos-phenolic composite journal bearing*, Compos. Struct., vol. 65, 2004, no. 1, pp. 37–46.
29. S. B. Glavatskih and M. Fillon: *TEHD Analysis of Thrust Bearings With PTFE-Faced Pads*, J. Tribol., vol. 128, 2006, no. 1, p. 49.
30. O. Nosko, T. Nagamine, A. L. Nosko, A. M. Romashko, H. Mori, and Y. Sato: *Measurement of temperature at sliding polymer surface by grindable thermocouples*, Tribol. Int., vol. 88, 2015, pp. 100–106.
31. M. Hoić, M. Hrgetić, and J. Deur: *Design of a pin-on-disc-type CNC tribometer including an automotive dry clutch application*, Mechatronics, vol. 40, 2016, pp. 220–232.
32. E. Ciulli, P. Forte, M. Libraschi, and M. Nuti : *Set-up of a novel test plant for high power turbomachinery tilting pad journal bearings*, Tribol. Int., vol. 127, no. November 2017, pp. 276–287, 2018.
33. P. Śliwiński : *The Influence of Water and Mineral Oil On Mechanical Losses in the Displacement Pump for Offshore and Marine Applications*: Polish Marit. Res., vol. 25, 2018, no. s1, pp. 178–188.
34. A. Dadouche, M. Fillon, and J. . Bligoud: *Experiments on thermal effects in a hydrodynamic thrust bearing*, Tribol. Int., vol. 33, 2000, no. 3–4, pp. 167–174.
35. B. Remy, B. Bou-Saïd, and T. Lamquin : *Fluid inertia and energy dissipation in turbocharger thrust bearings*, Tribol. Int., vol. 95, 2016, pp. 139–146.
36. S. B. Glavatskih: *A method of temperature monitoring in fluid film bearings*, Tribol. Int., vol. 37, 2004, no. 2, pp. 143–148.
37. T. W. Kerlin and M. Johnson: *Practical Thermocouple Thermometry (2nd Edition)*. ISA, 2012.
38. W. Dai, B. Kheireddin, H. Gao, and H. Liang : *Roles of nanoparticles in oil lubrication*, Tribol. Int., vol. 102, 2016, pp. 88–98.
39. J. Duchowski : *Examination of journal bearing filtration requirements*, Lubr. Eng., vol. 09, 1998, pp. 1–9.
40. J. Duchowski, H. International, and J. Duchowski: *Filtration requirements for journal bearings exposed to different contaminant levels*, Lubr. Eng., vol. 06, 2002, no. July, pp. 34–39.
41. D. Hargreaves and S. C. Sharma: *Effects of solid contaminants on journal bearing performance*, Proceedings of the 2nd World Tribology Congress, 3-7 September 2001. pp. 237–240.

42. A. Dadouche and M. J. Conlon: *Operational performance of textured journal bearings lubricated with a contaminated fluid*, Tribol. Int., vol. 93, 2016, pp. 377–389.
43. M. M. Khonsari and E. R. Booser: *Effect of contamination on the performance of hydrodynamic bearings*, Proc. Inst. Mech. Eng. Part J J. Eng. Tribol., vol. 220, 2006, no. 5, pp. 419–428.
44. A. Akchurin, R. Bosman, P. M. Lugt, and M. van Drogen: *Analysis of Wear Particles Formed in Boundary-Lubricated Sliding Contacts*, Tribol. Lett., vol. 63, 2016, no. 2, pp. 1–14.
45. A. Akchurin, R. Bosman, and P. M. Lugt: *Generation of wear particles and running-in in mixed lubricated sliding contacts*, Tribol. Int., vol. 110, 2017, no. February, pp. 201–208.
46. A. Akchurin, R. Bosman, and P. M. Lugt: *A Stress-Criterion-Based Model for the Prediction of the Size of Wear Particles in Boundary Lubricated Contacts*, Tribol. Lett., vol. 64, 2016, no. 3, pp. 1–12.
47. G. Pintaude: *Characteristics of Abrasive Particles and Their Implications on Wear*, New Tribol. Ways, no. April 2011.
48. C. Q. Yuan, Z. Peng, X. C. Zhou, and X. P. Yan : *The characterization of wear transitions in sliding wear process contaminated with silica and iron powder*, Tribol. Int., vol. 38, 2005, no. 2, pp. 129–143.
49. L. Peña-Parás et al.: *Effects of substrate surface roughness and nano/micro particle additive size on friction and wear in lubricated sliding*, Tribol. Int., vol. 119, 2018, no. February 2017, pp. 88–98.
50. S. M. Park, G. H. Kim, and Y. Z. Lee: *Investigation of the wear behaviour of polyacetal bushings by the inflow of contaminants*, Wear, vol. 271, 2011, no. 9–10, pp. 2193–2197.
51. E. Szymczak and D. Burska : *Charakterystyka rozkładu wielkości cząstek in situ w strefie rozplywu wód Wisły (Zatoka Gdańska) (in Polish)*. ?? pp. 1–2, 2014.
52. M. Damrat, A. Zaborska, and M. Zajaczkowski: *Sedimentation from suspension and sediment accumulation rate in the River Vistula prodelta, Gulf of Gdańsk (Baltic Sea)*, Oceanologia, vol. 55, 2013, no. 4, pp. 937–950.
53. I. Geologiczny and I. Geologii ?? : *Litologia i skład mineralny osadów z dna Basenu Gdańskiego (in Polish)*, ?? vol. 313, 1980, no. 2.
54. T. Leipe and B. Sea : *The kaolinite/chlorite clay mineral ratio in surface sediments of the southern Baltic Sea as an indicator for long distance transport of fine-grained material*, Baltica, vol. 16, 2003, pp. 31–36.
55. A. Ya and T. Yu : *Revealing the influence of various factors on concentration and spatial distribution of suspended matter based on remote sensing data*, Proc. SPIE, vol. 9638, 2015, pp. 1–12.
56. Y. Solomonov: *Experimental investigation of tribological characteristics of water-lubricated bearings materials on a pin-on-disk test rig*, Yuriy Solomonov Master of Philosophy Thesis, The University of Adelaide School of Mechanical Engineering April 2014.
57. C. L. Dong, C. Q. Yuan, X. Q. Bai, Y. Yang, and X. P. Yan: *Study on wear behaviours for NBR/stainless steel under sand water-lubricated conditions*, Wear, vol. 332–333, 2015, pp. 1012–1020.
58. C. Yuan, Z. Guo, W. Tao, C. Dong, and X. Bai: *Effects of different grain sized sands on wear behaviours of NBR/casting copper alloys*, Wear, vol. 384–385, 2017, pp. 185–191.
59. C. P. Gao et al.: *Tribological behaviors of epoxy composites under water lubrication conditions*, Tribol. Int., vol. 95, 2016, pp. 333–341.
60. S. Thörmann, M. Markiewicz, and O. von Estorff: *On the stick-slip behaviour of water-lubricated rubber sealings*, J. Sound Vib., vol. 399, 2017, pp. 151–168.
61. B. S. Mann and V. Arya : *An experimental model for mixed friction during running-in*, Wear, vol. 253, 2002, no. 5–6, pp. 541–549.
62. L. Deleanu and C. Georgescu: *Water lubrication of PTFE composites*, Ind. Lubr. Tribol., vol. 67, 2015, no. 1, pp. 1–8.
63. S. Chen et al.: *Tribological properties of polyimide-modified UHMWPE for bushing materials of seawater lubricated sliding bearings*, Tribol. Int., vol. 115, 2017, no. 126, pp. 470–476.
64. A. Ismailov, M. Järveläinen, and E. Levänen: *Problematics of friction in a high-speed rubber-wheel wear test system: A case study of irregularly rough steel in water lubricated contact*, Wear, vol. 408–409, 2018, no. December 2017, pp. 65–71.
65. C. Dong, L. Shi, L. Li, X. Bai, C. Yuan, and Y. Tian : *Stick-slip behaviours of water lubrication polymer materials under low speed conditions*, Tribol. Int., vol. 106, 2017, no. October 2016, pp. 55–61.
66. S. Meicke and R. Paasch : *Seawater lubricated polymer journal bearings for use in wave energy converters*, Renew. Energy, vol. 39, 2012, no. 1, pp. 463–470.
67. S. Jiang, Z. Guo, C. Yuan, A. Liu, and X. Bai : *Study on the tribological properties of modified polyurethane material*

for water-lubricated stern bearing, J. Appl. Polym. Sci., vol. 135, 2018, no. 22, pp. 1–13.

68. J. Bouyer and M. Fillon : *Experimental measurement of the friction torque on hydrodynamic plain journal bearings during start-up*, Tribol. Int., vol. 44, 2011, no. 7–8, pp. 772–781.
69. Ł. Breńkacz and G. Żywica : *The experimental identification of the dynamic coefficients for two hydrodynamic journal bearings*, SIRM 2017, Schwingungen rotierenden Maschinen, vol. 24, 2017, no. 96, pp. 157–164.
70. T. Dimond, R. D. Rockwell, P. N. Sheth, and P. E. Allaire: *A New Fluid Film Bearing Test Rig for Oil and Water Bearings*, Struct. Dyn. Parts A B, Vol. 5, 2008, pp. 1101–1110.
71. N. Wang and Q. Meng : *Research on wireless nondestructive monitoring method for film pressure of water-lubricated bearing*, Ind. Lubr. Tribol., vol. 67, 2015, no. 4, pp. 349–358.
72. N. Wang, Q. Meng, P. Wang, T. Geng, and X. Yuan: *Experimental Research on Film Pressure Distribution of Water-Lubricated Rubber Bearing With Multiaxial Grooves*, J. Fluids Eng., vol. 135, 2013, no. 8, p. 84501.
73. S. Yamajo and F. Kikkawa: *Development and Application of PTFE Compound Bearings*, Dyn. Position. Conf., 2004.

CONTACT WITH THE AUTHORS

Agnieszka Barszczewska

e-mail: agnbarsz@pg.edu.pl

Gdańsk University of Technology
ul. Narutowicza 11/12, 80-233 Gdańsk

POLAND

Ewa Piątkowska

e-mail: ewapiatk@pg.edu.pl

Gdańsk University of Technology
ul. Narutowicza 11/12, 80-233 Gdańsk

POLAND

Wojciech Litwin

e-mail: wlitwin@pg.edu.pl

Gdańsk University of Technology
ul. Narutowicza 11/12, 80-233 Gdańsk

POLAND