

ULTRASONIC DETECTION OF THE INTRAVASCULAR FREE GAS PHASE IN RESEARCH ON DIVING

Ryszard Kłós

Polish Naval Academy, Gdynia, Poland

ABSTRACT

The article presents a unique atypical application of the sonography technique and a methodological description of the introduction of this technique to research. The Bayesian approach applied to validation of the Doppler method for intravascular detection of the free gas phase instead of typical statistical inference has been demonstrated in the article. It describes the place of this method in the diving research work conducted in the Polish Naval Academy without any detailed analysis of the results achieved in the studies on decompression supported by ultrasonic detection of the free gas phase in venous vessels. It is a commonly held opinion that Doppler ultrasonic detection of the intravascular free gas phase is not a procedure that can be particularly useful in decompression research. The main objection is that detection of the free gas phase in venous vessels is a weak function to predict the presence of the free gas phase in tissues and arterial blood, so this method is not suitable for assessing the risk of decompression. Only a few countries disagree with this commonly held view and use this method to assess the risk of decompression in decompression studies. France has introduced detection of the free gas phase in venous vessels for diving research and then, together with Canada, improved this method, and developed it to a standard form. Based on the published results of the Canadian research, the technique was evaluated at the Naval Academy using statistical methods. The Academy accepted and adopted the results of this research and started to use this method in its own research on decompression over 25 years ago and continues to use it to great effect.

Keywords: diving, decompression, decompression investigation

INTRODUCTION

CONTEXT

In ocean engineering and underwater technology diving technologies still play an important role, especially in offshore industries and search and rescue at sea. Combat and police divers are powerful forces who play a key role as response tactical teams, reconnaissance units, and for mine countermeasures, submarine rescue, combat search and rescue and so on. Recreational diving is also an important segment of the sports market.

Diving apparatuses are still important appliances on board marine vessels that can be used in emergency situations, such

as shipboard damage control, evacuation of people cut off by water in ship compartments and still alive in air pillows, etc. Decompression sickness *DCS* is dangerous from the depth of 12 mH_2O , and prevention of *DCS* symptoms involves the implementation of effective decompression procedures.

As it follows from the above, despite the huge market for the unmanned technologies, it is still important to improve diving technology through scientific progress.

PROBLEMS RELATED TO MODELLING

Navies constantly want to increase operational security. One possible way is to look for factors that have a decisive impact on the safety of diving. In an analytical approach, the diving schedule model can be divided into several sub-models.

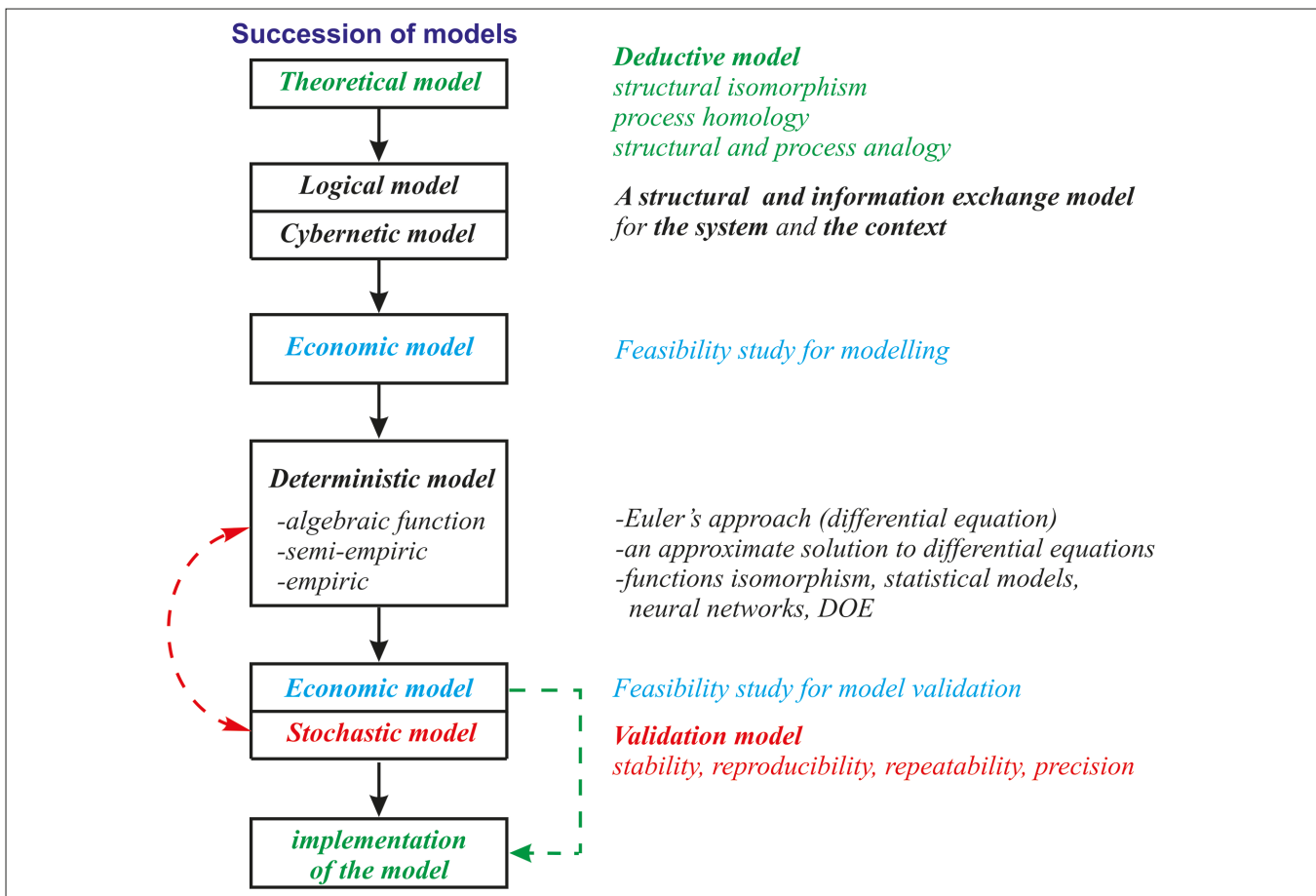

Fig. 1. Scheme of the research project conducted to determine, validate and approve the model

Our perception of reality is gained only by building models, because the reality is too complicated for us. The model is a maximally simplified system, reflecting a real system that is able to ensure the reproducibility of the process we are interested in with the required precision and accuracy.

The system is a set of distinct elements with links between them. Elements and connections between them form the structure. In the structure relations and arrangement can be distinguished. The arrangement can be distinguished by series and order. The subsequent activities that are aimed at achieving a specific target are a process. The process can occur in a system whose elements ensure its sustainability.

The theoretical model is a deductive model resulting from the knowledge of the system and processes occurring in it. Theoretical models are most often based on structural isomorphism to the known systems, homology with the known processes or structural and process analogy. Cybernetic logical models reflect the basic structure of the system, ensuring analogous information exchange inside and outside the modelled system (Fig. 1). The economic model is used to assess the profitability of developing a model of the system that is of interest to us, for example in the form of a feasibility study.

The most frequent models are statistical or deterministic models. Validation models are most often the former. Before commencing the validation process, its feasibility should be reconsidered, taking into account the economic model.

A positive result of the validation process allows the model to be implemented. Validation of the received decompression schedules is based on the stochastic model.

STUDIES ON NEW DECOMPRESSION TABLES

The processes accompanying decompression constitute a complex problem for scientific research, because of the lack of precise measurement methods to monitor processes taking place in body tissues. The mathematical models applied to describe the decompression process reflect only a small part of the total phenomena taking place and they do not reflect the physiological processes taking place during decompression. Such mathematical models should be treated only as computational methods for the approximation of safe decompression procedures, because they are developed by matching experimental data to relatively simple mathematical functions.

Collecting data used to develop decompression procedures through experimental diving investigations is difficult, consuming much time and money. The data obtained are sometimes controversial and susceptible to various interpretations. However, it is the only way to obtain and validate such procedures.

In the laboratory research phase, new mathematical models of decompression are developed or already existing models

are modified. The proposed procedure thus obtained is tested. The experimental process is established in accordance with the principles specified in the Helsinki Declaration. Chamber tests, where most of the process parameters can be accurately controlled, are essential for the laboratory research phase, but pool tests and open water tests may also be performed. Such experiments should be continued until the results, based on medical and scientific considerations, justify a transition to the implementation phase. The laboratory phase may be stopped at any time. The number of laboratory tests required to start the implementation phase may vary, according to the model being tested. If an entirely new model is being tested, then the number of trials must be large enough to achieve an adequate confidence level for acceptance of the results. On the other hand, if the model had been previously tested and only minor changes were introduced, then the number of tests needed may be smaller. After completing the test program, the decision to terminate the laboratory research phase and begin the implementation phase is taken.

In the implementation phase, the validation tests are performed under the proposed operational diving conditions together with a high concern for diver safety. Management of the dives is given to the most experienced operational diving teams, with the assistance of well-equipped medical and scientific teams to monitor the medical and physiological status of the dive subjects and the safety of the dive procedures being tested. This is to ensure that a sufficiently large quantity of high quality data is obtained while maintaining a high level of safety for the experimental divers. This will also form the basis for the decision to subsequently approve the decompression tables for operational use.

However, this is not the end of the research process. During operational use, the decompression procedures and the results of the dives carried out will be monitored. If any problems appear, they should be investigated in the research phase again. If a decision about the withdrawal of the decompression procedure or about its modification is made, the process will have to start anew.

EXISTING SOLUTIONS

Traditionally the decompression risk assessment has been conducted using statistical inference methods. The classic approach is based on statistical inference based on experimental dives. The collected results are used to assess the risk of decompression sickness *DSC*, expressed as the likelihood of occurrence of *DSC* symptoms in the future by statistical inference based on a binomial distribution or using classical sequential analysis [1].

A conclusion based only on the occurrence or absence of *DSC* symptoms seems to be quite primitive, which is why methods were sought that could be used to determine, according to a more accurate scale, the likelihood of occurrence of *DSC* symptoms. The method of determining the concentration of the free gas phase in venous vessels by Doppler ultrasonography detection was chosen. This popular method was adopted and developed by the French

and Canadians, and the achievements of the latter have been adopted and developed in Poland [2, 3].

The simple Doppler Bubble Monitoring *DBM* application (ultrasound detection of free gas phase signals transformed using the electronics into an audible beep) is useful in experimental studies of decompression profiles. *DBM* is a standard tool used by several laboratories conducting research on decompression [4, 5]. Its main advantage is that it can be used outside the laboratory in an actual time under pressure. The Naval Academy has used Doppler ultrasonic detection of the intravascular free gas phase as a method for monitoring decompression safety in the course of diving technology-focused research and development for over 25 years to great effect [6].

METHOD

DECOMPRESSION RESEARCH

The article presents the role of the Doppler ultrasonic detection of the intravascular free gas phase based on the example of the organisation of research on using diving apparatus type SCR-CRABE (Semi-Closed Circuit Rebreather Complete Range Autonomous Breathing Equipment). A similar approach was presented earlier [7].

In the classic approach, the modelling of decompression schedules is based on the homology of ventilation models of the breathing space in the diving apparatus and decompression model. The decompression and ventilation models are exponential, so it is possible to consolidate them [8]. In the new approach, the main model of diving technology is divided into several component models. The decompression model is divided into several sub-models, most of which are deterministic models (cause and effect models) (Fig. 2). Among these sub-models, the most important is the ventilation model of the breathing space in the diving apparatus.

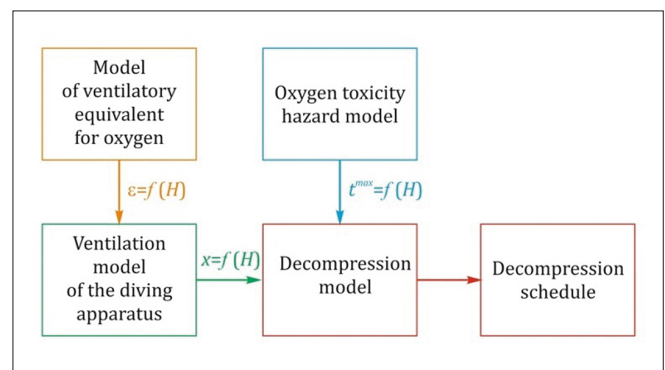

Fig. 2. The models of phenomena that affect a decompression schedule or contribute to the decompression model [15]

The theoretical model of breathing space ventilation in the diving apparatus comes from the differential balance of the mass of oxygen and the mass of the breathing mixture as a whole (Fig. 3) [9]:

$$x(t) = x_w - \varepsilon_p \cdot \varepsilon \cdot \varepsilon_k + (x_0 - x_w + \varepsilon_p \cdot \varepsilon \cdot \varepsilon_k) \cdot \exp\left(-\frac{V_0 \cdot r^2}{\varepsilon \cdot u} \cdot t\right) \quad (1)$$

where:

- x_w – molar fraction of oxygen in fresh breathing gas,
- $\varepsilon_p = \frac{p_0}{p}$ – pressure module,
- p – pressure at diving depth,
- p_0 – normal pressure,
- $\varepsilon = \frac{\dot{V}}{\dot{V}_E}$ – breathing module (ventilation equivalent for the oxygen),
- \dot{V} – stream of consumed oxygen,
- \dot{V}_E – ventilation of lungs,
- $\varepsilon_k = \frac{1-x_w}{r}$ – module representing structural solution of breathing space in the diving apparatus,
- r – volume ratio of the small bag to the large bag $r = \frac{1-x_w}{r}$,
- U – volume of the large bag,
- u – volume of the small bag,
- x_0 – molar fraction of oxygen breathing space before diving apparatus is started,
- t – ventilation time.

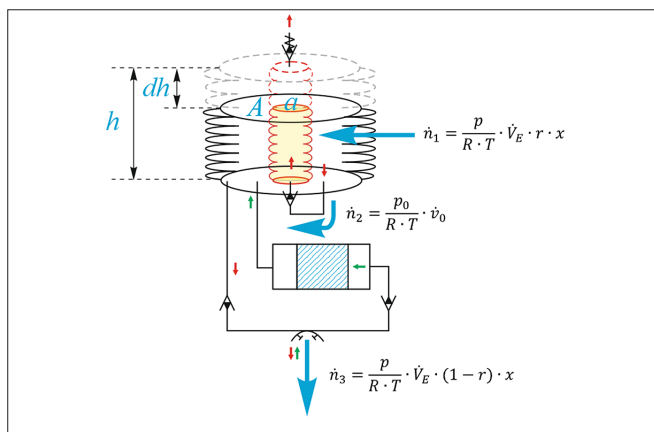

Fig. 3. The theoretical ventilation model for an example of a diving apparatus

The ventilation model contains some criterial numbers. Among them is a ventilation equivalent for oxygen ε (breathing module). The ventilation equivalent for the oxygen empirical model has a significant impact on the ventilation model of the diving apparatus breathing space. The parameters of this

model were collected from the measured stable state of the oxygen concentration in the breathing loop (Fig. 4).

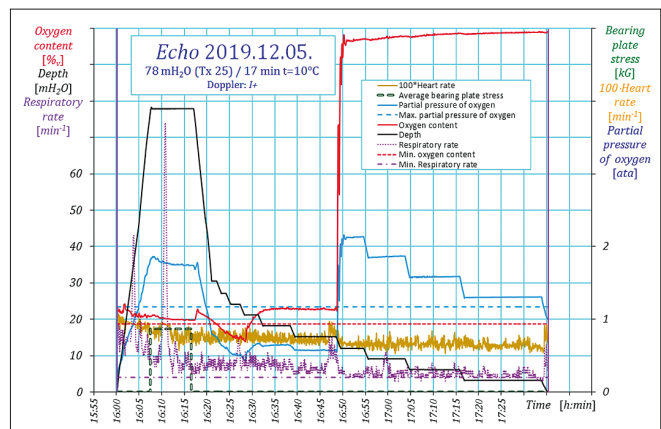

Fig. 4. Data from real experimental dive

The consolidated model of ventilation and ventilation equivalent for oxygen has been confirmed in simulation conditions. To check the ventilation model, the combination of three simulators: respiratory, metabolic and hyperbaric, was used (Fig. 5).



Fig. 5. The set-up of combined simulators: respiratory, metabolic and hyperbaric

Under stable conditions, astonishingly good compatibility of the ventilation model and experimental measurements for real diving apparatus has been achieved (Fig. 6).

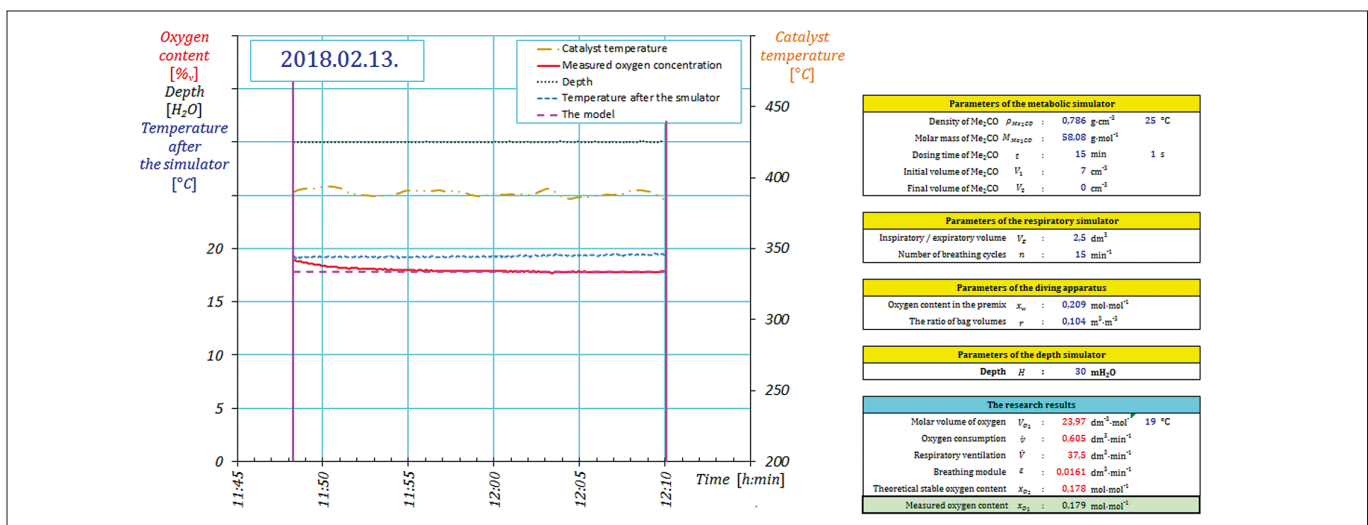

Fig. 6. Example of one result received from combined simulators: respiratory, metabolic and hyperbaric

The consolidated model of ventilation, risk of oxygen toxicity and decompression was tested manned under simulation conditions in the hyperbaric simulator. For assessing safe decompression, the $ZH-L_{12}$ decompression model was used [10, 11]. The adequacy of the assumed mathematical model at the limits of oxygen partial pressures was tested during pressure tests with the use of diving apparatuses. The experiments were carried out in parallel with verification experiments of the decompression procedure based on the experiments carried out in the hyperbaric swimming simulator (Fig. 7). The sample results are shown in Fig. 4.

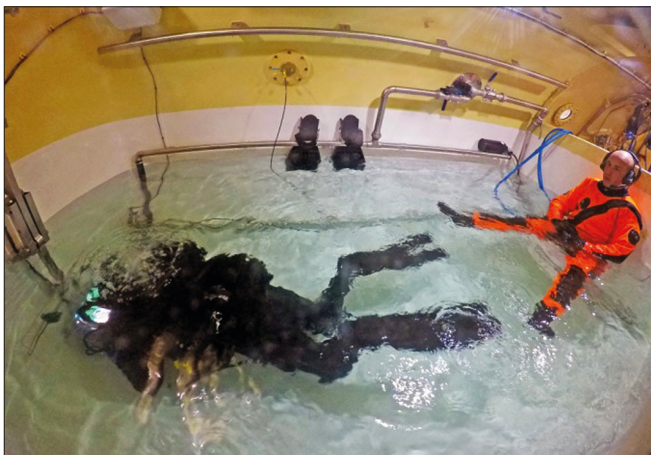

Fig. 7. The hyperbaric swimming simulator

ULTRASONIC DETECTION OF INTRAVASCULAR FREE GAS PHASE

The adequacy of the decompression schedule is assessed under the control of the Doppler ultrasonic detection of the intravascular free gas phase by the Doppler Bubble Monitoring system DBM9008 [12] (see Appendix).

The symptoms of decompression sickness *DCS* are not necessarily accompanied by the formation of the free gas phase in venous blood as measured by the DBM9008 instrument. Measuring the concentration of the free gas phase in tissues is much more suitable for assessing the development of *DCS* risk symptoms. As for the results of the Canadian research, good statistical agreement between *DCS* symptoms and the concentration of the free gas phase in veins is recorded.

The Polish research on decompression safety is based on measurements performed with the DBM9008 carried out to predict the risk of *DCS* in the intravascular free gas phase. These long-term studies seem to have confirmed the usefulness of this method.

A description of the statistical inference procedures used for decompression sickness risk and the measurement scores of intravascularly free gas phase were presented earlier [13].

In practice, three places are used for determining the free gas phase. These are the precordial and both subclavian veins (see Appendix).

The precordial area should be monitored from the vena cava side, because any vein gas from the venous system should pass

through this area before it is removed from the lungs. The free gas phase is rarely observed on the arterial side. Gas bubbles reach the arterial side only when the bubbles of the free gas phase on the vein side are so numerous that they exceed the capacity to filter their entire population through the lungs. By monitoring the precordial area it is possible to estimate the total number of bubbles entering from the whole of the vein blood at a given time.

In practice, not all gas bubbles can be detected because the amplitude of the signal coming from smaller bubbles may be smaller than the amplitude of the basic background signal derived from the heart rate and blood flow.

Proper placement of an ultrasound transducer over the heart is very important from the point of view of the techniques for detecting gas bubbles in vein blood. The operation of the tricuspid valve may help locate the optimal placement of the probe, but its movement tends to mask the signals coming from the free gas phase bubbles, so it should not be allowed to dominate in the listening signal.

In some divers, especially those with a massive physique, it may be difficult to get a good signal around the heart area. In this case, the diver should lean forward, causing the heart to move closer to the chest wall. This will increase the signal strength.

Sometimes it is difficult to get a good signal in the precordial area. In this case, the gas bubble may not be detected in this place. Therefore, it is recommended that other places be monitored as well. Subclavian veins are easy to monitor, and gas bubbles are easily detected there. For this reason, it has been routine to study the presence of bubbles in both the subclavian veins and the precordial region. It is often possible to detect the free gas phase in the subclavian veins when it is not possible to detect them in the precordial region. However, monitoring only the subclavian veins is not sufficient, because gas bubbles flowing from other parts of the body could then be undetected. The subclavian vein is located close to the subclavian artery, so it is easy to find by searching for a pulsating sound coming from the artery. The probe should be positioned so as to obtain the maximum venous signal and the minimal signal from the artery. Monitoring of the subclavian veins is accompanied by a characteristic Doppler signal, similar to a blowing wind. This sound becomes louder when the blood flow through the vein increases as a result of clenching of the fist by the subject on the monitored side.

RESULTS AND DISCUSSION

PREVIOUSLY OBTAINED SOLUTIONS

Despite the earlier validation, the method based on the intravascular free gas phase measurements for predicting *DCS* risk had to be validated in Poland. The Bayesian approach was chosen for the validation process [14]. In the inference process the physiological symptoms of *DCS* and the results of

measurements of the presence of free gas phase in the blood veins at 1726 exposures in DR-DC Toronto were compared [4, 15] (Table 1).

Tab. 1. The cumulative frequency distribution of DSC and measurements of the signal from DBM for air and other nitrogen-oxygen decompression, where: \neg DSC – represents the number of the absence of DSC symptoms, DSC – represents the number of the onset DSC symptoms, \neg G – represents the number of signals from DBM suggesting the absence of DSCV symptoms, G – signal from DBM indicating conditions for onset of DSC symptoms for the free gas phase in the precordial zone or in the subclavian vein obtained by selecting the larger of the signals

	G	\neg G	TOTAL
DCS	36	5	41
\neg DCS	401	1284	1685
TOTAL	437	1289	1726

In the investigations described, the acceptable safe gradient was taken as $< II + [2, 3]$. Estimation of the probability of events involving the absence of the signal designated as dangerous $B:\{\neg G\}$ with the subsequent onset of DCS for air and Nitrox decompression $A:\{DCS\}$, is: $P(\neg G|DCS) \stackrel{\Delta}{=} \frac{n(\neg G \cap DCS)}{n(DCS)} = \frac{5}{41} \cong 0.12$ (Table 1). For the case of lack of diagnosis by non-detection of intravascular free gas phase $B:\{\neg G\}$ for air and the other nitrogen-oxygen decompression procedure with the DCS occurrence $A:\{DCS\}$ the appropriate probability is $P(DCS|\neg G) \stackrel{\Delta}{=} \frac{5}{1289} \cong 0.004$ and this is small enough for us to recommend this method for use in support of decompression research.

In accordance with the global trends, the Polish Navy has adopted measures to encourage the development of decompression systems, for which the DCS risk is less than 1% [16]. Hence, for the evaluation of experimental dives, the adoption of this assumption level seems to be $P(DCS) = 0.01$. Using this assumption, data from Table 1 and the Bayesian approach, it is possible to calculate the probability of an event in which, despite exceeding the boundary for an undetected signal originated from the intravascular free gas phase during motion or at rest, the diver will have the symptoms $P(DCS|\neg G) \stackrel{\Delta}{=} \frac{0.01}{0.37 \cdot 0.01 + 0.90 \cdot 0.99} \cdot 0.37 \cong 0.004, < 1\%$ Fig. 8) [17].

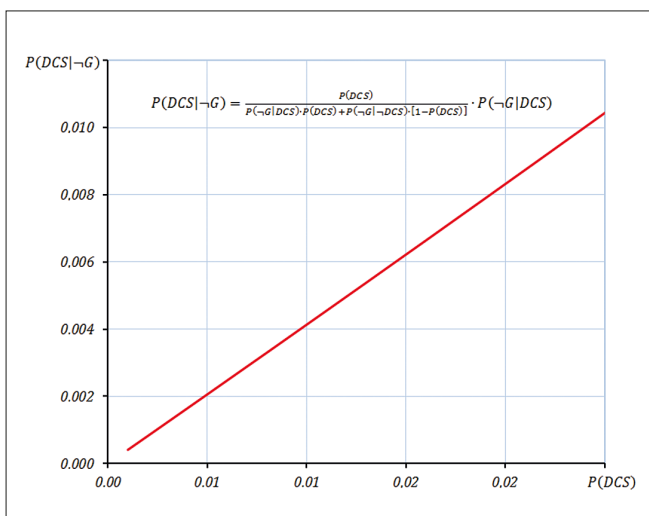

Fig. 8. Probability $P(DCS|\neg G)$ that, despite the fact that a free gas phase was not detected during motion or at rest $B:\{\neg G\}$, a diver will have DCS symptoms $A:\{DCS\}$

These results suggest that the diagnostic techniques when using DBM9008 are highly reliable and sufficient to assess the DCS risks during experimental dives. These results are entirely consistent with the previous observations recorded by the Polish Navy. Other researchers have drawn similar conclusions by using other inference methods [18, 19].

CONCLUSIONS

In Poland, the Ethics Committee does not accept delay when DCS symptoms occur, therefore all potentially dangerous situations identified by the DBM9008 measuring system have been corrected by the oxygen flush procedures (normobaric or hyperbaric).

The DBM9008 system is used to measure signals from the precordial and subclavian regions only with the use of a precordial probe. It is difficult to get a good signal in the precordial area, so it has been routine to study the presence of bubbles in both the subclavian veins and the precordial region. The latest research validates our approach [17].

Monitoring always takes place after the defined movement (see Appendix). The measurements are carried out at 30-minute intervals, up to 3 hours after the end of decompression or longer, until the free gas phase signal disappears. Three measurements are made in the heart area and each subclavian vein during the one test period. The highest value is selected, and later converted into the degree of gas bubble gradation according to the table in the Appendix. A signal above II+ degree of gas bubble gradation is considered dangerous and the diver needs an additional decompression (normo- or hyperbaric with the use of oxygen or not). A description of the statistical inference procedures used for decompression sickness risk and the measurements scores of the intravascularly free gas phase was presented earlier [13].

Since 2009, over 250 experimental dives have been performed using a SCR-CRABE dive device. These experimental dives have been carried out using gas mixtures of nitrogen-oxygen and nitrogen-helium-oxygen in the range between the surface and 80 mH_2O depth. Several dive technologies have been launched, including new decompression schedules dedicated to the SCR-CRABE mine countermeasure diving system. While using the DBM9008 system, potentially dangerous decompression situations have been recorded three times. All of them have been corrected by oxygen flushing.

Whenever the potential risk of DCS was theoretically increased, the bubble score also increased. This relationship was valid below and inside the so-called “grey area” in which it is difficult to clearly determine the risk of decompression. This method has not been tested in Poland for the region with a high probability of DCS (over 10%).

Over 400 experimental dives under the control of the DBM9008 system have been carried out without any symptoms of DCS in the last 20 years. Thus, the Naval Academy can recommend ultrasonic detection of the intravascular free gas phase as very useful in research on diving.

ACKNOWLEDGEMENTS

This article is the result of work and research projects conducted by the author:

- Oxygen diving technology – research sponsored by State Committee for Research project № 148-101/C-T00/96 carried out in 1996–1998 [18, 19]
- The mathematical models of diving apparatus atmosphere ventilation with partial regeneration of the breathing medium – research sponsored by State Committee for Research project № 0T00A 072 18 carried out in 2000–2002 [20, 21]
- The method of saturation dives – project № R00-O0014/3 sponsored by the State Committee for Research carried out in 2007–2009 [14]
- A new generation of breathing simulator – grant № O N504 497734 sponsored by the State Committee for Research carried out in 2007–2010 [12]
- Decompression design of in combat missions – project № O R00 001 08 sponsored by the State Committee for Research carried out in 2009–2011 [9]
- Decompression design for MCM dives – project agreement № DOBR/0047/R/ ID1/2012/03 sponsored by the State Committee for Research carried out in 2012–2015 [8, 18]
- Decompression design for MCM/EOD dives II – project agreement № DOB-BIO8/09/01/2016 sponsored by the State Committee for Research – in progress.

Apart from financing, the research presented required access to unique combat equipment. I express my gratitude to the Navy Command of the Republic of Poland and the 3rd Ship Flotilla for the trust that I received. The research included experiments on humans, which required the consent of the Scientific Research Ethics Committee. I thank the Military Medical Institute for their support in obtaining such consent. I would like to express my appreciation to the experimental divers for their willingness to take the risk of participating in the research and for having faith in my competence. I would also like to thank the staff and civilian employees of the Polish Navy and Naval Academy for their help in preparing such extensive experiments.

APPENDIX Ultrasonic detection of intravascular free gas phase

The Naval Academy has used the Doppler ultrasonic detection of the intravascular free gas phase as a method for monitoring decompression safety in the course of diving technology-focused research and development for over 25 years to great effect.

In the Naval Academy, the Doppler Bubble Monitoring DBM9008 system (Fig. 9 and Table 2) is used in the procedure for ultrasonic detection of the intravascular free gas phase. The simple DBM application¹ is useful in experimental studies of decompression profiles. DBM is a standard tool used by several laboratories conducting research on decompression [4, 5]. Its main advantage is that it can be used outside the laboratory in real time under pressure.

¹ Ultrasound detection of free gas phase signals transformed using the electronics into audible beeps.



Fig. 9. Doppler Bubble Monitor DBM9008 (photo: TECHNO SCIENTIFIC INC.)

Tab. 2. Description of Doppler Bubble Monitor shown in Fig. 9

Probe	Two piezoelectric ceramic elements (transmit and receive) are both rigidly and permanently situated inside the head of the sensor assembly. Two styles of probes are: a pencil probe for the subclavian region and precordial type with variable focal lengths for the precordial region
Operation mode	Continued wave
Operating frequency	2.5 MHz
Acoustical pressure	15 mW · cm ⁻¹
Power supply	Batteries 4 × AA
Mechanical features	Rugged splash proof sealer container
Focal length	Precordial: 7.9 cm and 10.5 cm; subclavian: 1 cm

The DBM measuring system is a simple and inexpensive device, but using this technique requires a skilled and experienced operator. The operators of the auscultatory DBM device require about 3 months of intensive training, which, in the case of the interpretation of clinical ultrasound imaging, is much longer and depends on the scope of the authorisation granted. All the Academy operators completed a course conducted by DR-DC Toronto (former Defence and Civil Institute of Environmental Medicine, Toronto). The experimental results are easily understood by other scientists because of the application of a standard *K-M* code procedure which has been used for signals classification [3, 22].

In practice, certain places are used for determining the free gas phase. During the research described, the precordial and both of the subclavian veins are used for determining the free gas phase.

The precordial area should be monitored from the vena cava side, because any vein gas from the venous system should pass through this area before it is removed from the lungs. The free gas phase is rarely observed on the arterial side. Gas bubbles reach the arterial side only when the bubbles of the free gas phase on the vein side are so numerous that the capacity to filter their entire population through the lungs is exceeded. By monitoring the precordial area, it is possible to estimate the total number of bubbles entering from the whole of the vein blood at a given time.

In practice, not all gas bubbles can be detected, because the amplitude of the signal coming from smaller bubbles may be smaller than the amplitude of the basic background signal derived from the heart rate and blood flow.

Proper placement of an ultrasound transducer over the heart is very important from the point of view of the techniques for detecting gas bubbles in vein blood. The operation of the tricuspid valve may help locate the optimal placement of the probe, but its movement tends to mask the signals coming from the free gas phase bubbles, so it should not be allowed to dominate in the listening signal.

In some divers, especially those with a massive physique, it may be difficult to get a good signal around the heart area. In this case, the diver should lean forward, causing the heart to move closer to the chest wall. This will increase the signal strength.

Sometimes it is difficult to get a good signal in the precordial area. In this case, the gas bubble may not be detected in this place. Therefore, it is recommended that other places be monitored as well. Subclavian veins are easy to monitor, and gas bubbles are easily detected there. For this reason, it has been routine to study the presence of bubbles in both the subclavian veins and the precordial region. It is often possible to detect the free gas phase in subclavian veins when it is not possible to detect them in the precordial region. However, monitoring only subclavian veins is not sufficient, because gas bubbles flowing from other parts of the body could then be undetected. The subclavian vein is located close to the subclavian artery so it is easy to find it by searching for a pulsating sound coming from the artery. The probe should be positioned so as to obtain the maximum venous signal and the minimal signal from the artery. Monitoring of the subclavian veins is accompanied by a characteristic Doppler signal, similar to a blowing wind. This sound becomes louder when the blood flow through the vein increases as a result of clenching of the fist by the subject on the monitored side.

It is also possible to monitor other places such as femoral veins and main veins. Femoral veins may be examined for the presence of the free gas phase in legs. Main veins are hard to access. The lower main vein is available for examination. In this case, the probe must be pushed deep into the abdominal wall. It is important not to confuse signals coming from the intestines with signals coming from the free gas phase in the inferior vena cava. Checking for bubbles in the brain can be achieved by monitoring the jugular veins. If there are plenty of bubbles in the precordial region, the jugular vein is worth examining.

Identifying the bubbles in the precordial region in the course of ultrasonic detection of the free gas phase is the most difficult task because the signals are masked by the signal coming from the movement of the structural elements of the heart. And unfortunately, this skill can only be mastered over a sufficiently long period of practice. It is recommended that people learning the Doppler technique of detecting the free gas phase are instructed by an experienced person. Monitoring should be carried out in two cases: standing at rest and after a well-defined movement. The goal of the movement is to temporarily increase the number of bubbles squeezed out of the tissues into the bloodstream. This is especially useful when

there are small numbers of bubbles. In the case of monitoring located in the precordial region, this movement is defined as a deep knee bend and squat. The subject has to bend his knees deeply and then immediately get up, keeping the transducer probe in the selected location so that the probe will not move. In the case of monitoring located in the subclavian region, this movement tightens the fist on the monitored side, followed by rest. If femoral veins or lower veins are examined, the subject is asked to raise first one then the other leg or do a calf raise.

It is advisable to record a reference signal for each diver before each dive. If later on the observers are not sure about the presence of the free gas phase, they can listen to the reference signal. Recording the reference signal helps the observer to familiarise himself with the characteristic sounds of each diver's heart.

Divers can be monitored in different stages of staying under pressure, but most often monitoring is done after the dive. After the pressure exposure is over, the divers should be monitored at half-hour intervals, for at least 3 hours after the end of decompression, or until the free gas phase disappears. As experience shows, the formation of the free gas phase can occur 1-4 hours after the end of decompression.

It is advisable that the monitored signals be recorded and recommended that a complete commentary on the recording be made. Parallel to the commentary, written documentation should also be collected. During sound recording, signal level indicators should be observed to ensure that the amplitude of the signal is adequate. In order to make sure that the signal has been saved correctly, it should be played back. If it is possible, investigators should work in pairs. One places the probe and maintains the signal at the appropriate level, while the other one records the signals. Both should interpret the signals and cooperate with each other.

Three parameters are used to describe the signal coming from the free gas phase. Each parameter is classified on a relative scale from 0 to 4. The frequency and amplitude are classified on an identical scale for rest and movement. The third parameter for rest and movement is defined in a different manner. For rest, it is expressed on the percentage scale, while for movement, on the duration scale. The combination of these three code parameters can be reduced to a single-digit *K-M* code.

The first parameter is the frequency representing the number of gas bubbles per one heartbeat. The method for determining this parameter is given in Table 3, where for the relative code 4 the bubbles are so numerous that their numbers cannot be estimated.

Tab. 3. Frequency parameter for *K-M* code

Code	Frequency [numbers]
0	No bubbles 0
1	Single bubbles 1-2
2	Single bubbles 3-8
3	Waving and rumbling signal 9-14
4	Continuous signal

Time duration represents the ratio of the time of occurrence of the signal from the free gas phase in relation to the duration of the measurement, expressed as a percentage. The method of estimating this parameter is presented in Table 4. For example, if 1-2 gas bubbles (frequency parameter is 1 from Table 3) occurred during 20 out of 100 heartbeats, the time duration parameter would be 2 from Table 4.

Tab. 4. Time duration parameter for K-M code for rest

Code	Time duration [%]
0	No bubbles 0%
1	1%–10%
2	10%–50%
3	50%–99%
4	100%

If the same signal, 3-8 bubbles, coming from the free gas phase occurs during 20 heartbeats per 100, and if during an additional 40 heartbeats 1-2 gas bubbles occur, the frequency parameter can be chosen as 2 from Table 3, and the time duration can be chosen as 2 from Table 4, because the signal has been observed for 20% of the heartbeats or the time duration parameter will be 3 from Table 4 for the frequency code 1 from Table 3, because for more than 50% of the signal occurrence (ratio is 60 to 100) its frequency code can be assigned as 1 from Table 3. As shown in Table 7, almost the same final effect of signal classification can be achieved in several ways.

Movement is a transient event, while rest is treated as a quasi-permanent event. Due to this difference, for movement, the second parameter will not be expressed as the percentage of time duration, but as the time of cycle duration.

The duration of measurement refers to 10 heartbeats starting from the end of the movement and counting as the number of heartbeats attributable when the number of gas bubbles as defined in Table 3 is recorded. The measurement cycle consists of 10 heartbeats for measurements located in the precordial area or as the percentage of heartbeats when the signal from gas bubbles is recorded for other places (Table 5).

Tab. 5. Time duration parameter for K-M code for movement

Code	Duration of bubbles [heartbeats (percent)]
0	0 (0%)
1	1-2 (10%–20%)
2	3-5 (30%–50%)
3	6-10 (60%–100%)
4	Continuous >10 (100%)

For example, if 9-14 gas bubbles are observed in each of the first 4 heartbeats per 10 heartbeats after movement, then the code of the time duration parameter from Table 5 is 2 for the frequency parameter code 3 from Table 3, provided that the number of bubbles has the tendency to decrease. If the number of gas bubbles for the next 4 heartbeats falls to 3-8, the duration code will be 3 for the frequency code 2.

The amplitude Ab of the signal produced by the gas bubbles compares to the amplitude Ac of the normal signal

coming from the heartbeat or flowing blood. The method for determining the amplitude parameter is given in Table 6.

Tab. 6. Amplitude parameter for the K-M code

Code	Amplitude
0	No bubbles
1	barely perceptible $Ab \ll Ac$
2	moderate amplitude $Ab < Ac$
3	comparable amplitude $Ab \approx Ac$
4	maximum amplitude $Ab > Ac$

The three designated codes are presented in the order of the parameters: frequency, time duration and amplitude. The resulting K-M code is stored in the form of fpa for rest and fda for the movement case.

Table 7 shows the method for converting the recorded three-parameter K-M code into a single-parameter code of bubble gradation. This method is convenient, but the original K-M code contains more information and should also be stored. In addition to the recommended recording of audio signals, the data on diving and descriptions of the symptoms of decompression sickness should be recorded.

Tab. 7. Conversion of the K-M code to the degree of gas bubble gradation

fpa	g	fpa	g	fpa	g	fpa	g
111	I-	211	I-	311	I	411	II-
112	I	212	I	312	II-	412	II
113	I	213	I+	313	II	413	II+
114	I+	214	II+	314	II	414	III-
121	I+	221	II-	321	II	421	III-
122	II	222	II	322	II+	422	III
123	II	223	II+	323	III-	423	III
124	II	224	II+	324	III	424	III+
131	II	231	II	331	III-	431	III
132	II	232	III-	332	III	432	III+
133	III-	233	III	333	III	433	IV-
134	III-	234	III	334	III+	434	IV
141	II	241	III-	341	III	441	III+
142	III-	242	III	342	III+	442	IV
143	III	243	III	343	III+	443	IV
144	III	244	III+	344	IV-	444	IV

$fp(d)a$ – code K-M
 g – degree of gas bubble gradation
 f – frequency parameter
 p or d – time duration parameter for rest or movement
 a – amplitude parameter

It is often possible to assign more than one classification to one signal. To decide which classification to use, the bubble gradation should be determined for individual signals and the highest value should be selected. For example, for codes 232 and 322, the gradation is: III- and II+ respectively, so code 232 should be chosen.

For movement, each measurement should be classified and the most representative code should be selected out of them. If codes 222, 232 and 332 have been assigned to three measurements, then the central value of 232 should be chosen. A deviation from this rule occurs when two measurements give a value of 0, while in the third one the free gas phase is observed. In this case, the higher classification should be chosen, because the most important effect of measurements is to distinguish between cases when there is the free gas phase and when there is no gas phase.

REFERENCES

1. Wald A. (1947): *Sequential Analysis*. John Wiley, New York.
2. Nishi R. Y. (1990): Doppler evaluation of decompression tables. In: Lin Y. C., Shida K. K. (Eds.). *Man in the sea*. Best Publishing, San Pedro.
3. Nishi R. Y., Brubakk A. O., Eftedal O. S. (2003): Bubble detection. In: Brubakk A. O. Neumann T. S., *Bennett and Elliott's physiology and medicine of diving*. 5th Ed. Saunders, Edinburgh.
4. Eftedal O. S. (2007): *Ultrasonic detection of decompression induced vascular microbubbles*. Norwegian University of Science and Technology Faculty of Medicine Department of Circulation and Medical Imaging, Trondheim, ISBN 978-82-471-3697-3.
5. Seddon F. M., Thacker J. C., Gilbert M. J., Anthony T. G. (2010): *Doppler monitoring of compressed air workers; Belfast sewer project*. Health and Safety Executive Offshore Technology, Norwich. RR788 Research Report.
6. Kłos R. (2010): *Detekcja śródnaczyniowej wolnej fazy gazowej*. Polish Hyperbaric Research, Vol. (32), 15–30.
7. Blatteau J. E., Hugon J., Gempp E., Castagna O., Pény C., Vallée N. (2012): *Oxygen breathing or recompression during decompression from nitrox dives with a rebreather: effects on intravascular bubble burden and ramifications for decompression profiles*. Eur J Appl Physiol., Vol. 112, 2257–2265; DOI: 10.1007/s00421-011-2195-6. Epub 2011 Oct 14.
8. Kłos R. (2011): *Polish Decompression System for CRABE Diving Apparatus*. Polish Hyperbaric Research, Vol. 4(37), 43-50.
9. Kłos R. (2012): *Możliwości doboru ekspozycji tlenowo-nitroksowych dla aparatu nurkowego typu AMPHORA – założenia do nurkowań standardowych i eksperymentalnych*. Polskie Towarzystwo Medycyny i Techniki Hiperbarycznej, Gdynia, ISBN 978-83-924989-8-8.
10. Bühlmann A. A. (1984): *Decompression-Decompression Sickness*. Springer-Verlag, Berlin, ISBN 3-540-13308-9; ISBN 0-387-13308-9.
11. Bühlmann A. A. (1995): *Tauchmedizin*. Springer-Verlag, Berlin, ISBN 3-540-58970-8.
12. Kłos R. (2002). *Metabolic simulator supports diving apparatus researches*. Sea Technology, Vol. (12), 53–56.
13. Kłos R., Nishi R., Olszanski R. (2002): *Validation of diving decompression tables*. Internat Marit Health, Vol. 53, 1–4.
14. Kłos R. (2014): *Helioksove nurkowania saturowane – podstawy teoretyczne do prowadzenia nurkowań i szkolenia*. Polskie Towarzystwo Medycyny i Techniki Hiperbarycznej, Gdynia, ISBN 978-83-938322-1-7.
15. Sawatzky K. D. (1991): *The relationship between intravascular Doppler-detected gas bubbles and decompression sickness after bounce diving in humans*. York University, Toronto.
16. Huggins K. E. (1992): *The dynamics of decompression workbook*. The University of Michigan, Ann Arbor.
17. Kłos R. (2007): *Zastosowanie metod statystycznych w technice nurkowej – Skrypt*. Polskie Towarzystwo Medycyny i Techniki Hiperbarycznej, Gdynia, ISBN 978-83-924989-26.
18. Eftedal O. S., Lydersen S., Brubakk A. O. (2007): *The relationship between venous gas bubbles and adverse effects of decompression after air dives*. Undersea Hyperb Med., Vol. 2(32), 99–105.
19. Hugon J., Metelkina A., Barbaud A., Nishi R., Bouak F., Blatteau J. E., Gempp E. (2018): *Reliability of venous gas embolism detection in the subclavian area for decompression stress assessment following scuba diving*. Diving Hyperb Med., Vol. 48, 132–140, DOI: 10.28920/dhm48.3.132-140.
20. Kłos R. (2011): *Możliwości doboru dekompresji dla aparatu nurkowego typu CRABE*. Polskie Towarzystwo Medycyny i Techniki Hiperbarycznej, Gdynia, ISBN 978-83-924989-4-0.
21. Kłos R. (2012): *Planning special combat operations with the use of the AMPHORA rebreather / Planowanie specjalnych operacji bojowych z wykorzystaniem aparatu nurkowego typu AMPHORA/*. Polish Hyperbaric Research, Vol. (38), 29–130.
22. Kłos R. (2002): *Mathematical modelling of the breathing space ventilation for semi-closed circuit diving apparatus*. Biocybernetics and Biomedical Engineering, Vol. 22, 79–94, ISSN: 0208-5216.
23. Kłos R. (2007): *Mathematical modelling of the normobaric and hyperbaric facilities ventilation*. Wydawnictwo Polskiego Towarzystwa Medycyny i Techniki Hiperbarycznej, Gdynia, ISBN 978-83-924989-0-2.
24. DCIEM (1986): *Procedures for Doppler ultrasonic monitoring of divers for intravascular bubbles*. Defense and Civil Institute of Environmental Medicine, Toronto, No. 86-C-25.
25. Kłos R. (2012): *Intravascular free gas phase detection*. Zeszyty Naukowe Akademii Marynarki, Vol. 188, 85–96, ISSN 0860-889X.

CONTACT WITH THE AUTHOR

Ryszard Kłos

e-mail: r.klos@amw.gdynia.pl

Polish Naval Academy
inż. J. Śmidowicza 69, 81-127 Gdynia
POLAND