

GENERATION OF H₂ ON BOARD LNG VESSELS FOR CONSUMPTION IN THE PROPULSION SYSTEM

Ignacio Arias Fernández

Manuel Romero Gómez

Javier Romero Gómez

University of A Coruña – Energy Engineering Research Group – School of Nautical Science and Marine Engineering, Spain

Luis M. López-González

Department of Mechanical Engineering, University of La Rioja, Spain

ABSTRACT

At present, LNG vessels without reliquefaction plants consume the BOG (boil-off gas) in their engines and the excess is burned in the gas combustion unit without recovering any of its energy content. Excess BOG energy could be captured to produce H₂, a fuel with high energy density and zero emissions, through the installation of a reforming plant. Such H₂ production would, in turn, require on-board storage for its subsequent consumption in the propulsion plant when navigating in areas with stringent anti-pollution regulations, thus reducing CO₂ and SO_x emissions. This paper presents a review of the different H₂ storage systems and the methods of burning it in propulsion engines, to demonstrate the energetic viability thereof on board LNG vessels. Following the analysis, it is identified that a pressurised and cooled H₂ storage system is the best suited to an LNG vessel due to its simplicity and the fact that it does not pose a safety hazard. There are a number of methods for consuming the H₂ generated in the DF engines that comprise the propulsion plant, but the use of a mixture of 70% CH₄-30% H₂ is the most suitable as it does not require any modifications to the injection system. Installation of an on-board reforming plant and H₂ storage system generates sufficient H₂ to allow for almost 3 days' autonomy with a mixture of 70%CH₄-30%H₂. This reduces the engine consumption of CH₄ by 11.38%, thus demonstrating that the system is not only energy-efficient, but lends greater versatility to the vessel.

Keywords: boil-off gas; efficiency; H₂ storage; LNG vessel, reforming

NOMENCLATURE

\dot{E}_{BOG}	BOG chemical exergy (kW)
\dot{E}_{CH_4}	CH ₄ chemical exergy (kW)
\dot{E}_{H_2}	Hydrogen chemical exergy (kW)
\dot{m}	Mass flow rates (kg/s)
a-q	Molar composition
h	Specific enthalpy (kJ/kg)
p	Pressure (Pa)
Pot	Power (kW)
\dot{Q}	Heat transfer rate (kW)
T	Temperature (°C)

SUBSCRIPTS

BOG	Boil-off gas
Comp	Compressor
Cons	Consumed
Reform	Reforming
Therm	Thermal

GREEK CHARACTERS

η	Energetic efficiency
η_{plant}	Plant efficiency
η_{thermal}	Thermal efficiency

ACRONYMS

4S DF	4-stroke dual fuel
4S	4-stroke
BOG	Boil-off gas
DF	Dual fuel
ECA	Emission control area
EES	Engineering equation solver
GCU	Gas combustion unit
GVU	Gas valve unit
HTS	High temperature shift
HX	Heat exchanger
LD	Low duty
LNG	Liquid natural gas
LTS	Low temperature shift
NG	Natural gas
IMO	International Maritime Organization
PSA	Pressure swing adsorption

INTRODUCTION

Strict marine pollution prevention regulations are forcing the maritime industry to develop technologies that adhere to such regulations, thereby currently giving rise to great technological and economic changes in the sector [22]. The IMO (International Maritime Organization), in Annex VI of the international MARPOL Convention, stipulates regulations pertaining to maritime pollution [9, 7]. IMO emission standards, commonly referred to as Tiers, mainly set limits on NO_x and SO_x emissions depending on the navigation zone, with more stringent requirements applicable to ships in Emission Control Areas (ECA) and ports [7, 24, 16].

A large expansion of the fleet of vessels engaged in the transport of liquefied natural gas (LNG) has been brought on by the high international demand for natural gas (NG) [1, 26, 28, 38]. Stringent anti-pollution regulations have led to dual-fuel (DF) propulsion plants being the most used system on board LNG vessels [14]. DF engines enable ships to be operated on different fuels simultaneously: diesel fuel and the boil-off gas (BOG) generated in the cargo tanks as a consequence of heat transfer from the environment [3, 15, 29, 37, 41]. The BOG that is not consumed in the propulsion plant is termed 'excess' and can be treated through various methods, the most notable being reliquefaction plants and gas combustion units (GCU) [3, 12-14, 17, 35, 39, 42].

The principle of the reliquefaction plant is to reliquefy excess BOG, thus avoiding losses in the load. The plant cost and high energy consumption must also be taken into consideration, however [35]. GCUs, in contrast, are installed on ships with no reliquefaction plants for the sole purpose of burning the excess BOG. Their main function is to control the pressure inside the tanks, but the plant performance is considerably reduced due to the impact of burning the excess without any contribution of energy [39, 41].

In consequence, strict anti-pollution regulations along with the wastage of excess BOG energy have prompted the need

to develop an efficient and environmentally friendly system. This was the standpoint taken by the authors when carrying out an energetic study of a hydrogen generation plant using the excess BOG [4]. Once this H_2 is available on board, its storage and consumption in the propulsion system need to be tackled. A wide range of H_2 storage methods were found after carrying out a thorough review of works in this field, but none were adapted to LNG vessel systems. Therefore, this paper seeks to present a study of the different storage methods and the alternatives for consuming H_2 on board, taking the latest technological developments in this field into account.

LNG VESSEL WITH DUAL-FUEL DIESEL ELECTRIC PROPULSION AND H_2 GENERATION

The conventional configuration of a dual-fuel diesel electric (DFDE) propulsion system is shown in Fig. 1. This configuration has four reciprocating 4-stroke dual-fuel (4SDF) internal combustion engines coupled to electric generators that power the entire ship, including the electric propulsion engines [8, 29, 39].

DF motors are designed to use methane as fuel, so it is essential that the BOG is treated in a gas management unit, as illustrated in Fig. 2. The most important process is to separate the methane from the other BOG components in order to avoid knocking and thus ensure correct combustion [29, 37, 39]. This process is performed in the oil mist separator [37, 40]. At the separator outlet, the BOG pressure increases in the blades of low-duty (LD) compressors and so does the variable speed [13, 37]. A gas heater is installed at the compressor outlet to stabilise the temperature prior to entering the gas valve unit (GVU) [30, 31, 37].

BOG generation is not always constant, so it could be that natural generation is not sufficient and thus must be forced through a 'forcing vaporiser' heat exchanger. Moreover, the system also comprises a GCU to burn the excess BOG that is not consumed by the propulsion system, with the sole purpose of stabilising the cargo tank pressure [8, 13, 35, 39]. Should such a situation occur, burning the excess in the GCU reduces the overall efficiency of the plant since none of its energy is exploited [3]. This therefore leads to the need to develop an alternative to recover the excess BOG energy. The authors propose the integration of a hydrogen generation plant through steam reforming, described in the following section.

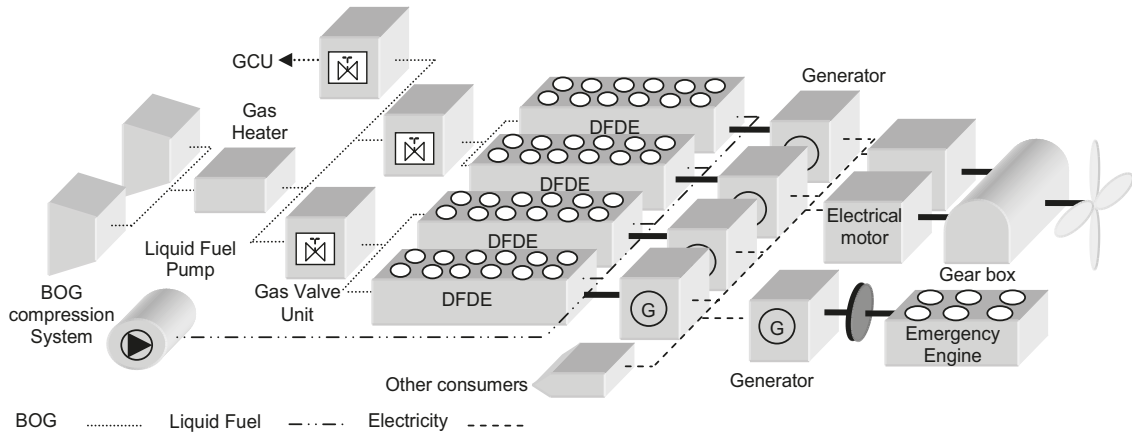

Fig. 1. Conventional configuration of diesel-electric propulsion using DF engines (4S)

H₂ GENERATION PLANT

Fig. 3 illustrates the layout of the reforming system analysed in [4]. The system is divided into three stages, which need to be carried out in order to complete the process of obtaining H₂ using BOG as the raw material. The BOG feeding the reformer is obtained from the excess generated on board (14) after its pressure is increased in the LD compressors (14-15) and not consumed in the electric generation engines (31).

In the first stage, called reforming (5-6), an endothermic reaction between steam (4) and NG (18) is performed inside a tubular reactor. This reaction takes place in a Ni catalyst on alumina located on the walls of the tubes, forming H₂ and CO at the tube outlet, as expressed through the following reaction [37, 40]:

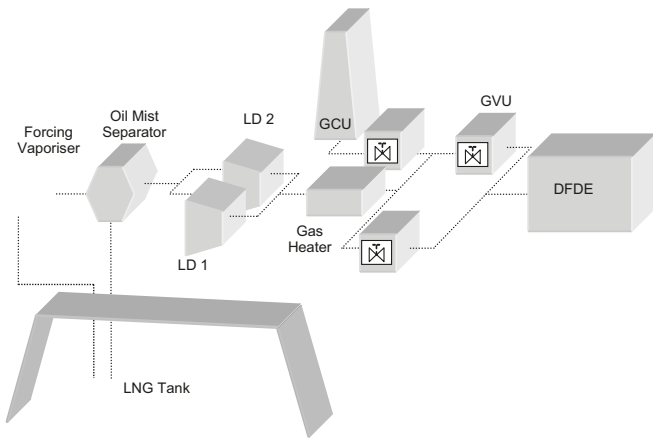
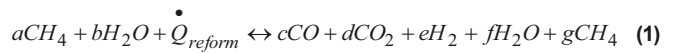

Fig. 2. Gas management system in a DF engine system (4S)

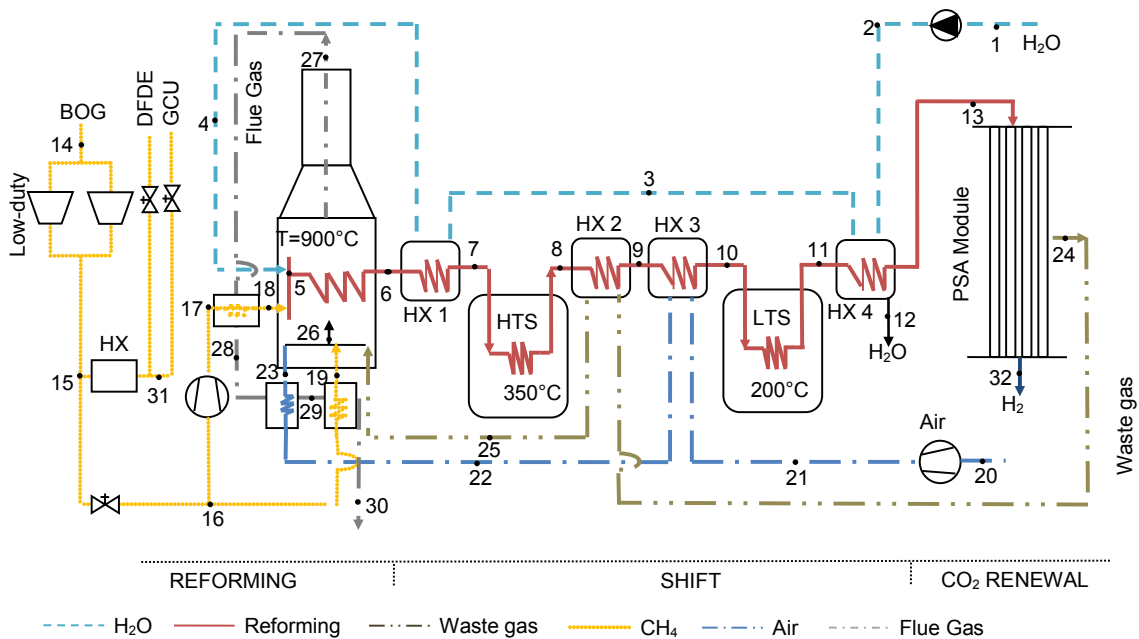
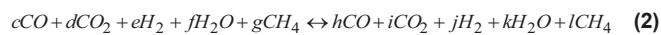

Fig. 3. Reforming process using steam from the excess BOG generated in the tanks of an LNG vessel

In Eq. (1), coefficients a, b, c, d, e, f and g represent the molar composition of the mixture, whilst \dot{Q}_{reform} is the heat externally supplied to produce the reaction between the NG and the H_2O . This reaction is performed at $900^\circ C$ and at a pressure between 15 and 3 MPa (16-17), reheating the mixture prior to entering the reformer for the purpose of enhancing the performance of the system [37]. The water is preheated in process (1-4) with the reforming gas itself, while the BOG, between (17-18), increases in temperature with the flue gases (27-28). The reaction between the NG and the steam is endothermic, hence requiring a substantial external heat contribution in order to reach the reaction temperature. The reaction is performed in a reactor located inside a furnace or boiler where combustion takes place at $1300^\circ C$ (26-27) between the BOG (19), the waste gas stream/flow from process (25) and air (23) [32, 36]. The air (20-23), and the CH_4 (16-19) are preheated before entering the combustion chamber to improve the process efficiency. Air is preheated with both the reforming stream (9-10) and exhaust gases (28-29), whereas the exhaust gases alone preheat the CH_4 (29-30).

The second stage, the Shift depicted in Fig. 3 between points (6-12), is designed to reduce the concentration of CO in the emissions generated in the first stage [40]. To achieve a reduction in CO concentration, two catalysts are placed in series, producing exothermic reactions that cause CO_2 emissions. The first stage, (7-8), is performed in a catalyst constructed with iron and chromium oxides, at about $350^\circ C$, based on Eq. (2) below, where coefficients h, i, j, k and l represent the molar composition of the mixture.



The second stage, (10-11), is performed in a copper zinc catalyst at a temperature of $200^\circ C$ [31, 37], obtaining CO concentration values of around 0.2-0.3% (wet basis) at the reformer outlet. This process is based on Eq. (3), where the coefficients l, m, n, o, p and q represent the molar composition of the mixture.



The values found at the outlet of the reformer after the two catalysts are 56.9% H_2 , 24.6% H_2O , 13.4% CO_2 , 3.5% CO, and 1.3% CH_4 [36]. This yielded gas stream is introduced into a heat exchanger to condense the H_2O present in the mixture (12-13).

The residual heat of the plant is exploited in order to improve the performance thereof, since the mixture must be cooled between the different stages described in the process to obtain the optimum temperature in each process. For this purpose, heat exchangers are used to heat both the BOG and H_2O used in the reforming [30, 31].

In the last step of the process, the stream of H_2 generated is purified (13-32), obtaining a purity of around 99.99% [37]. PSA (pressure swing adsorption) modules are used for

this, consisting of a structure made up of multiple packaged beds (activated carbon, alumina or zeolites), absorbing the impurities of the H_2 stream [31, 37].

A residual stream is produced in this step (24), comprising the rest of the gases that make up the mixture (H_2, CH_4, CO_2 and CO), which are recirculated to reduce the flow of fuel that feeds the boiler [30, 31].

The reforming process was the object of investigation in a paper produced by the authors [4], in which an energy analysis of the plant was performed, obtaining efficiency and thermal performance values based on the following equations:

Power consumed by the plant:

$$Pot_{cons} = \sum \dot{m}_n (h_{out} - h_n)_{pump} + \sum \dot{m}_n (h_{out} - h_n)_{air\ compr.} + \sum \dot{m}_n (h_{out} - h_n)_{BOG\ compr.} \quad (4)$$

BOG chemical energy at the reforming entrance:

$$\dot{E}_{BOG} = \dot{m}(PCI_{BOG} + h_{BOG}) \quad (5)$$

H_2 chemical energy at the reforming exit:

$$\dot{E}_{H_2} = \dot{m}(PCI_{H_2} + h_{H_2}) \quad (6)$$

CH_4 chemical energy for reforming combustion:

$$\dot{E}_{CH_4} = \dot{m}_{CH_4}(PCI_{CH_4} + h_{CH_4}) \quad (7)$$

Global energy efficiency of the plant:

$$\eta_{plant} = \frac{\dot{E}_{H_2}}{\dot{E}_{CH_4} + \dot{E}_{BOG} + Pot_{cons}} \quad (8)$$

Thermal efficiency of the plant:

$$\eta_{Thermal} = \frac{E_{H_2}}{\dot{Q}_{reform} + E_{BOG} + Pot_{cons}} \quad (9)$$

Table 1 contains the results obtained, displaying the hydrogen generated under conditions of maximum efficiency, the mass flows of each stream and the power consumed by the plant. It is important to mention that 0.37 kg/s of H_2 are generated for each kg/s of BOG.

Tab. 1. Results of the energetic study of the plant in Fig. 3

Parameters	Value
BOG compressor	205.10 (kW)
Water pump	5.09 (kW)
Air compressor	960.60 (kW)
η plant	64.04%
η thermal	74.49%

Parameters	Value
BOG	1 (kg/s)
Water	2.96 (kg/s)
BOG comb	0.41 (kg/s)
Air	11.41 (kg/s)
Waste gas	2.69 (kg/s)
Flue gas	14.52 (kg/s)
H ₂	0.372 (kg/s)

CHARACTERISTICS OF THE MODEL LNG VESSEL UNDER STUDY

This section studies the specific case of a vessel with a capacity of 173400 m³ of LNG, possessing the characteristics shown in Table 2. Data was collected during a 33-day voyage with the ship in maximum load conditions. In this type of ship the theoretical generation of BOG is considered to be 0.15%/day of the total cargo [15, 35]. A comparison is carried out in Fig. 4 between the theoretical and actual BOG, which is 0.13%/day, with both values being very similar.

Fig. 5 shows the values of the generated BOG; that consumed in the DF engines and that burned in the GCU throughout the crossing. An average of 228 m³/day of BOG is produced and the consumption needed for the 4 DFDE engines is 182 m³/day, generating an excess that needs to be burned in the GCU to stabilise the pressure inside the cargo tanks. The purpose of installing the H₂ generation plant is to take advantage of the excess BOG (46 m³/day), thus increasing the performance of the plant while simultaneously reducing the pollutant emissions of the vessel.

Once H₂ has been generated on board, it must be stored to be later consumed in the propulsion plant or auxiliary elements of the ship. The sections below look into H₂ storage systems, and the different methods of consuming it on board.

Tab. 2. Characteristics of the model vessel and cargo

Vessel type	Gas carrier	
Cargo	LNG	
DNV classification	+1A1, oil tanker for liquefied gas, Vessel type 2G(-163°C, 500 kg/m ³)	
Propulsion system	4 x DFDE 4S	
Overall length	290 m	
Propulsive power	2 x 13240 kW (77.80 rpm)	
Speed	15 kn	
	Outbound	Inbound
LNG volume (m ³)	170841	163180
LNG temperature (°C)	-160	-159

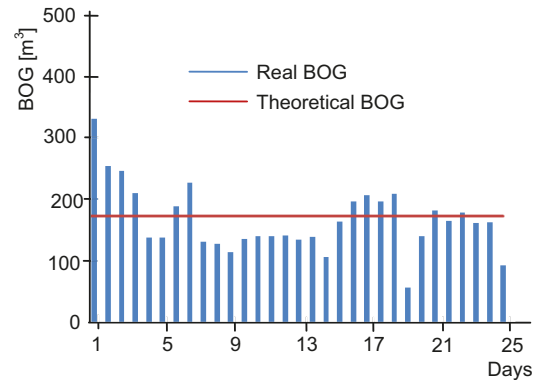

Fig. 4. Comparison between theoretical and actual BOG on an LNG vessel

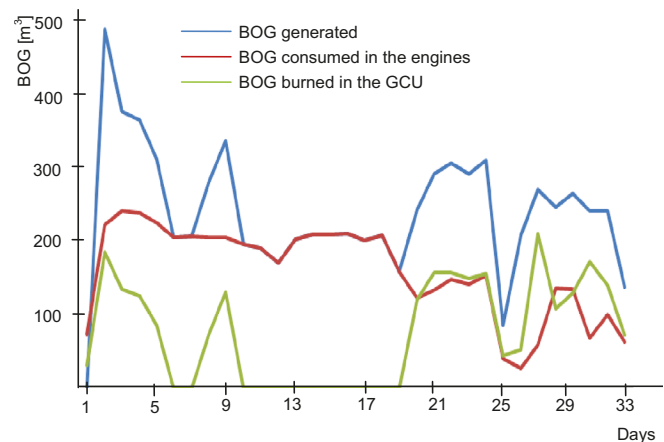

Fig. 5. Ratio of the BOG generated and that consumed in the propulsion plant and GCU under load conditions

H₂ STORAGE

There are currently a multitude of methods for storing H₂ in industrial plants, but none are adapted to LNG vessels. Fig. 6 illustrates the different storage methods that could be installed on an LNG vessel, classifying them according to the technology to be used [11, 19].

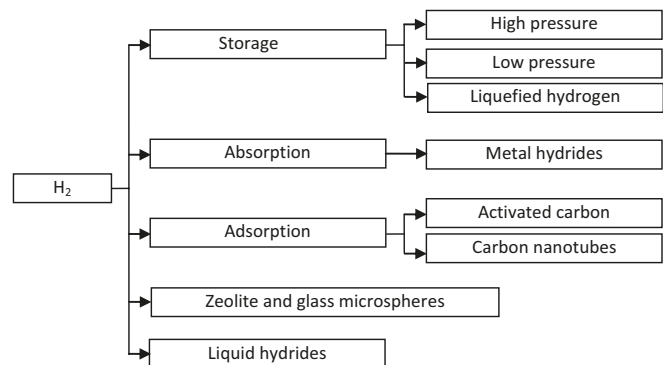

Fig. 6. H₂ storage methods

STORAGE OF H₂ IN TANKS

H₂ tank storage has been the most widespread method for over a hundred years [21]. This storage method can be done at low or high pressure, depending on the need and amount to be stored. Low-pressure storage is usually performed in systems that require a high H₂ flow, where production and consumption are carried out in the same plant [20]. This system does not bring about any significant problems and so, for this reason, was extended to the storage of other gases such as NG, with storage in large spherical tanks being the method of choice [20, 34].

Storing H₂ at high pressure enables the storage of a large quantity inside a reduced volume. The most frequent storage pressures are in the range of 20 to 45 MPa [21], sometimes even reaching 70 MPa [6, 10, 43]. Storage cylinders for high pressures are usually cylindrical and the material in which they are manufactured depends on the specific needs, with steel, aluminium and carbon fibres being the most widely used [21].

Liquefying the H₂ for its subsequent storage is a method that achieves a high mass-volume ratio. The disadvantage of this system is that it demands a high amount of energy to reduce the temperature below its critical point (-239.8°C) [5, 33]. It is estimated that the energy input required for liquefaction is 1/3 of the H₂ energy [21].

H₂ STORAGE USING ABSORPTION

H₂ storage using metal hydrides is based on the property possessed by some metals of forming reversible covalent bonds when they react with H₂ [10]. This is a safe and reliable method of storage that consists of subjecting a metal to high H₂ pressures in order to trap the atoms in their crystalline structure [32]. The stored H₂ can be released by decreasing the external pressure of the metal or by heating it [21].

Group V transition metal alloys are the most commonly used for this method due to their high storage capacity and the low temperatures required to dissociate the hydride. As can be seen in reaction (10), an exothermic reaction takes place in the H₂ storage process to form the compound, where *M* represents the metal, element or alloy and *n* is the number of H₂ moles. The process of releasing the H₂, on the contrary, is an endothermic reaction, requiring an external heat input, as reflected in reaction (11) [43].

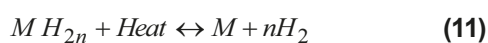
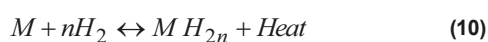

STORAGE THROUGH ADSORPTION

Hydrogen can be adsorbed and stored reversibly in carbon nanotubes or in graphite particles, depending on the pressure and temperature applied. Carbon nanotubes are made up of hexagonal carbon nets, forming light and porous tubes that are highly capable of storing hydrogen. Nanotubes can be classified into two groups; single-walled (SWNT) or multi-walled (MWNT), depending on the number of layers that compose it. The technique consists in distributing carbon nanotubes in a chamber where H₂ is introduced at a pressure with values of 1 to 10 MPa [32, 33, 43]. Temperature is another factor that affects the adsorption capacity of the system, with temperatures below ambient being favoured [33].

Another adsorption system worth emphasising is the storing of hydrogen in tanks filled with graphite particles. The material costs of this system are low in comparison with carbon nanotubes, whose high price is a serious drawback [31].

Adsorption systems generally pose a serious issue in terms of safety when transporting hydrogen because the volumetric and gravimetric density values are significantly below the minimum values established by state and international regulations. Improvements in transportation safety are currently being worked upon to make it a technology to consider because of its high storage capacity [36].

STORAGE IN GLASS AND ZEOLITE MICROSPHERES

The storage of H₂ in glass and zeolite microspheres is a rapidly expanding technology due to storage density limitations [33]. The system consists of storing H₂ at high pressure inside hollow spheres with diameters between 25 and 500 microns at a temperature in the range of 200 to 400°C [2, 18]. This high temperature is necessary to make the walls of the spheres permeable and allow the inward passage of gas. The spheres need to be heated to release the gas from them, or they can also be crushed, meaning, however, that they cannot be reused [18]. This system entails high costs in the materials used, and so is a process that is still under technological development [20].

STORAGE IN LIQUID HYDRIDES

The liquid hydride storage system allows for the safe storage of H₂ over long periods of time at reduced volumes [37]. Liquid hydrides are chemical compounds capable of binding hydrogen with cyclohexane metals, ammonia and methanol [21, 10, 43]. A dehydrogenation unit is needed to recover the stored hydrogen, thereby implying a costly system, but it must be highlighted that none of the stored H₂ is lost with this system [10].

CHOICE OF ONBOARD STORAGE SYSTEM

Given that an LNG vessel has a low temperature energy source, such as the load itself and the generated BOG, it is important to take advantage of this cold energy to

reduce the H₂ temperature before storage [3, 15, 39, 41]. Furthermore, vessels require simple and reliable plants to avoid compromising their safety. It is thus considered that the most appropriate storage method is pressurised and at low temperature due to the maturity and low cost of the technology [20, 21, 34, 43]. Placing the H₂ tanks inside the LNG cargo tanks could be considered as a strategic location. In this way, the stored H₂ is maintained at a low temperature without requiring energy input. The other systems, in effect, have been discarded due to the following:

- Storage using metal hydrides involves high costs and requires heat to release the H₂, and so its location inside LNG tanks is unfeasible as it increases the generation of BOG [15, 43].
- The method of adsorption with nanotubes offers low volumetric and gravimetric density values so it is not considered suitable for the transportation usage [32].
- The lack of safety in adsorption storage systems rules it out as an option to install on board. This system is high-risk because the volumetric and gravimetric density values are significantly below the minimum values established by state and international regulations [21, 33, 43].
- Glass and zeolite microspheres require large tanks because the storage density is very low, thus requiring large spaces on board to install the system [2, 18].
- Liquid hydrides are a system to be taken into account but it is discarded as a result of its high cost and safety issues resulting from the use of chemical compounds inside the cargo tanks [10, 43].

In the following sections, the authors propose a low temperature and pressurised storage system, suited to an LNG vessel.

HYDROGEN STORAGE SYSTEM ON THE MODEL SHIP

The H₂ generated on board can be stored in three different ways: pressurised, cooled and combined. The three systems are based on different configurations, using only compressors and heat exchangers. This section analyses each system individually to later carry out an energy balance of the plant. To simplify the analysis, the following is assumed:

- The NG is composed of only methane.
- It is a steady-state system.
- Adiabatic components.
- Kinetic and potential energy are negligible in comparison to thermal.

The equations for performing the energy analysis of the plant are presented below.

Energy balance in heat exchangers:

$$\sum \dot{m}_{in} (h_{out} - h_{in})_{in} = \sum \dot{m}_{out} (h_{out} - h_{in})_{out} \quad (12)$$

Plant power consumption:

$$Pot_{cons} = \sum \dot{m}_{in} (h_{out} - h_{in})_{H_2 compr.} \quad (13)$$

To study each storage system, the key parameters such as the H₂ pressure and temperature are modified at different points in the process. The simulation is performed using EES (Engineering Equation Solver) software, which usefully includes the properties of a wide range of fluids and optimisation tools [25]. Table 3 depicts the parameters assumed for the simulation of the model plant. The results obtained in the study are referred to in kg/s of reforming BOG.

Tab. 3. Main parameters and assumptions for the analysis of the storage plant

System	Parameters	Value
LNG tanks	LNG temperature	-163°C
	LNG pressure	0.1 MPa
Oil mist separator	BOG temperature (in)	-156°C
	BOG pressure (in)	0.1 MPa
	Methane temperature (out)	-130°C
	Methane pressure (out)	0.1 MPa
Low-duty	Methane pressure (in)	0.1 MPa
	Methane pressure (out)	0.5 MPa
Reforming	Methane temperature	25°C
	Methane pressure	0.5 MPa
	H2O temperature	0.1 MPa
	H2O pressure	25°C
	H2 pressure	1.3 MPa
Seawater	Temperature	25°C

STORAGE OF PRESSURISED H₂

A compressor is installed in the pressurised H₂ storage plant, at the exit of the reforming plant, to reduce the specific volume and to store a greater amount. As shown in Fig. 7, an exchanger with seawater must be installed to stabilise the H₂ temperature at around 25°C prior to storing it in the tank, as it is considerably increased in the compression process.

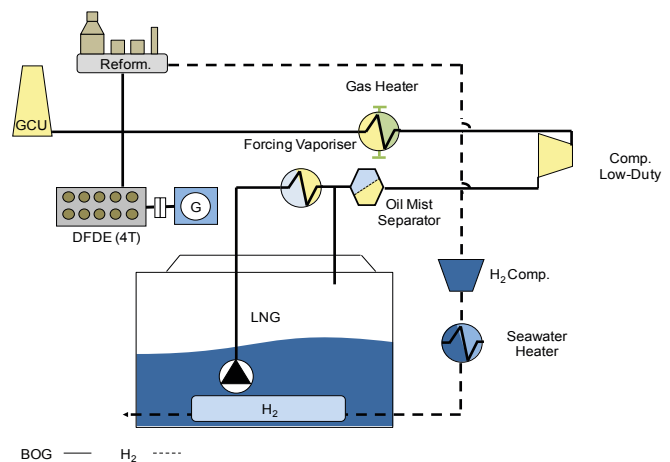

Fig. 7. Pressurised H₂ storage

In this case, the storage pressure of the H₂ is varied from 1.3 MPa (pressure at the exit of the reforming plant) to 70 MPa (the highest for storing H₂ under pressure) [10]. As the H₂ pressure increases, its specific volume decreases, but the work performed by the compressors considerably increases from 114.1 kW for 1.4 MPa to 12 MW for 70 MPa, as reflected in Fig. 8(a). In this process, a temperature of 789°C is reached at a pressure of 70 MPa in the compressor outlet, as shown in Fig. 8(b). These H₂ conditions prompt the need to install an exchanger with seawater in order to stabilise the temperature at around 25°C before storing it in the tank and thus avoid an increase in BOG generation, whilst simultaneously reducing the volume of the H₂ tank.

This system allows a reduced storage volume of H₂ due to the high working pressures. However, given that the high temperatures reached compromise the safety of the vessel, and that high energy consumption is required, this system is discarded for use on board.

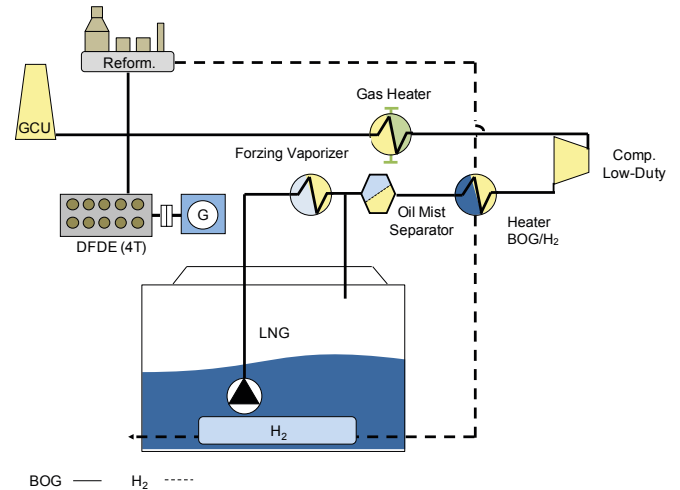

Fig. 9. Cooled H₂ storage

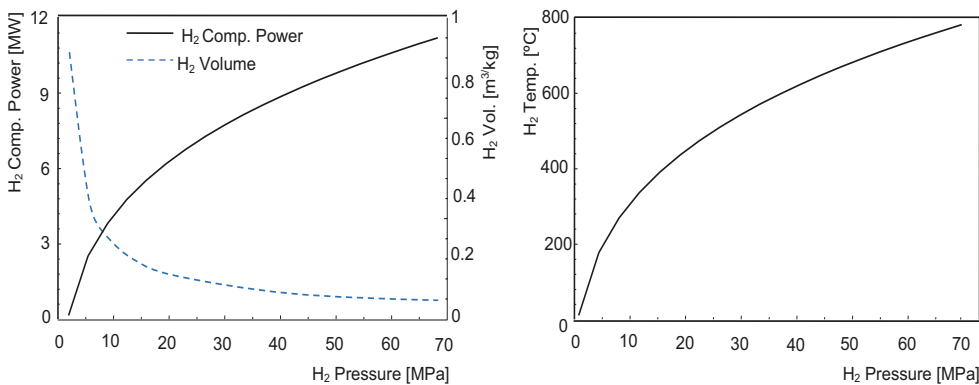

Fig. 8. Effect of varying the H₂ pressure: (a) power consumed and specific H₂ volume; (b) temperature at the compressor outlet.

STORAGE OF COOLED H₂

H₂ storage by means of cooling involves a single heat exchange step at the exit of the reforming plant, as shown in Fig. 9. The H₂ is cooled with the BOG generated in the cargo tanks, which is at a temperature of -130°C at the entrance of the exchanger.

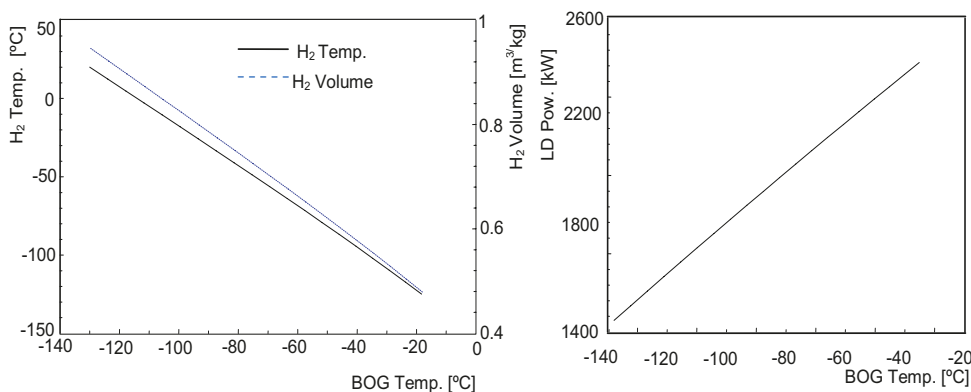

Fig. 10. Effect of H₂ temperature variation: (a) BOG temperature and H₂ specific volume; (b) LD compressor work

In this case, the H₂ temperature is reduced at the exit of the reforming plant prior to entering the storage tanks from 25°C (H₂ temperature at the exit of the reforming plant) to -125°C (limited by the BOG temperature, which is -130°C).

Fig. 10(a) shows that as the H₂ temperature decreases so does its volume, whilst the BOG temperature increases as

a consequence of the heat exchange. As the BOG temperature increases, its specific volume and the work performed by the LD compressors increase by 44%, from 1407 kW to 2521 kW, as illustrated in Fig. 10(b).

Lowering the H₂ temperature achieves a decrease in its specific volume and in the generation of BOG, but it must be taken into account that the work of the LDs considerably increases. Fig. 11 illustrates the variation in BOG generation depending on the H₂ storage temperature, varying from 25°C to -163°C. In the worst-case situation, which is to introduce H₂ at 25°C, an excess of only 0.0075% more than the theoretical amount would be generated,

which for a ship of 173000 m³ is 0.15%/day [13, 17]. This system is ruled out for onboard use due to the high specific volume and the increased consumption in the LDs.

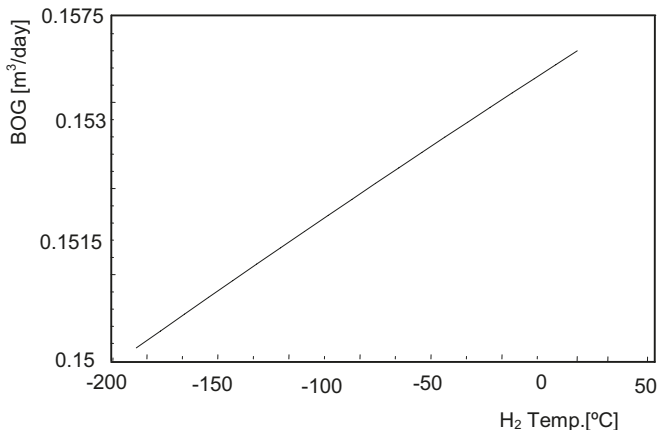

Fig. 11. BOG generation according to the H_2 storage temperature

STORAGE OF PRESSURISED AND COOLED H_2

Fig. 12 depicts the combined storage process, where the H_2 is cooled and pressurised to store it in a concentric tank inside the cargo tanks [23, 27]. The BOG generated as a result of heat transfer from the environment is drawn from the cargo tanks to prevent overpressure that could cause damage to them (13).

The extracted BOG is treated in the oil mist separator (1-2), whose purpose is to separate the methane from the other NG components for consumption in the engines (6), the H_2 generation plant (7) or the GCU (5). At the outlet of the separator, the methane is introduced into a heat exchanger (2-3) to cool the generated H_2 prior to the compression and storage process (9-10). Following heat exchange with the H_2 , the BOG is compressed in the LDs at a pressure of 0.5 MPa (3-4) and re-cooled in an exchanger with seawater (16-17) to stabilise it at a temperature of 25°C (4-5) and enable its consumption in the engines (6), reforming plant (7) and GCU (5).

The H_2 obtained in the reforming plant (9-10) is cooled with the BOG at the oil mist separator outlet (2-3), as explained above. On leaving the exchanger, the H_2 is compressed (10-11) and as a result its temperature is raised again, hence needing to cool it (11-12) in an exchanger with seawater (14-15). The pressurised and cooled H_2 enters the concentric tanks (18) located inside the cargo tanks (13), where it continues to

decrease in temperature because of heat transfer with the LNG, which is at a temperature of -163°C.

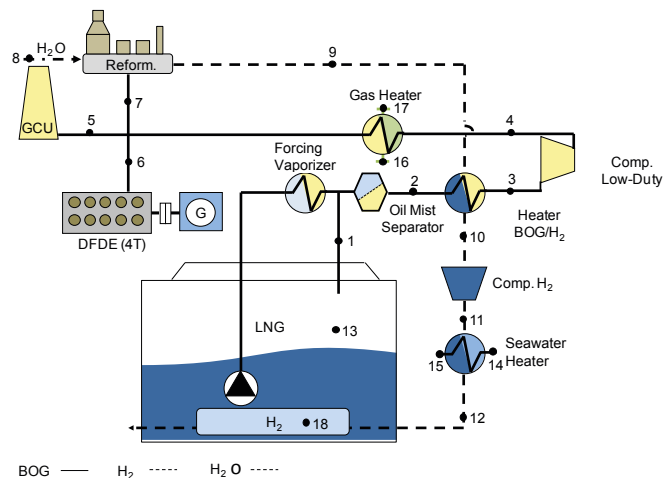

Fig. 12. Storage of pressurised and cooled H_2 in a concentric tank

A study is carried out in this process, varying the H_2 pressure and temperature at different points of the system in order to analyse the behaviour of the elements of the plant and the conditions of the hydrogen for its storage.

In the first case, the H_2 temperature at the exit of the exchanger with the BOG (point 10) is varied from 25°C to -125°C (a process restricted by the BOG temperature), keeping the storage pressure constant at 20 MPa. As shown in Fig. 13(a), as the H_2 decreases in temperature, the BOG increases in temperature, resulting in an increase in LD compressor consumption from 1407 kW to 2524 kW.

Fig. 13(b) compares the power consumed by the H_2 compressor and the LDs in relation to the H_2 temperature. With a constant H_2 temperature of 20°C at the exchanger outlet, the LD compressors show a consumption of 1407 kW, and the H_2 compressors of 6447 kW. Alternatively, if the H_2 temperature at the exchanger outlet is decreased to -125°C, the power consumed by the LDs increases to 2524 kW, while that of the H_2 compressor decreases to 3438 kW. In conclusion, it should be emphasised that cooling the H_2 reduces the total consumption of the plant (H_2 and LD compressor).

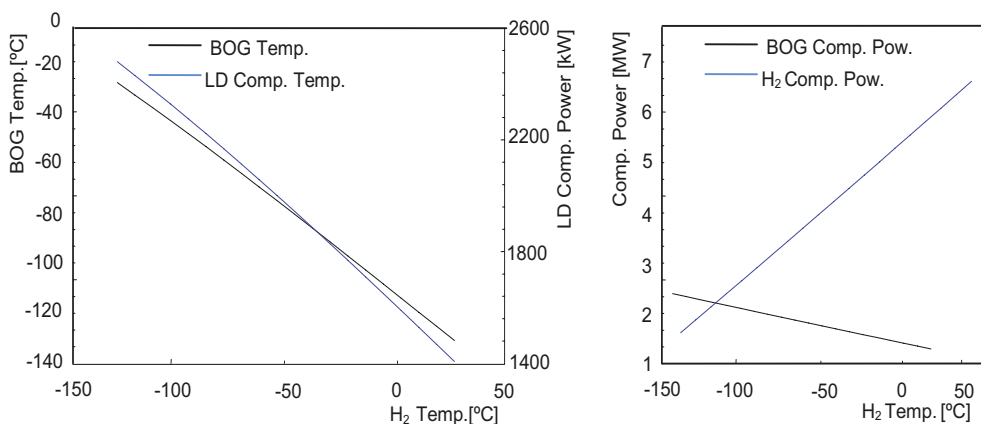

Fig. 13. Effect of H_2 temperature variation: (a) Comparison between BOG temperature, H_2 temperature and LD power; (b) Comparison between H_2 temperature and compressor power

In the second case, the H_2 temperature is maintained at -125°C at the exchanger outlet, and the storage pressure is varied between 1.3 and 70 MPa (point 11). As shown in Fig. 14(a), as the H_2 storage pressure increases, the compressor consumption increases proportionally to 6447 kW. As a result of the increase in H_2 pressure from 1.3 to 70 MPa, its temperature increases respectively from -130 to 264.5°C, thus creating

a need to install a seawater exchanger in the compressor discharge to avoid generating BOG when introducing the H_2 into the storage tank.

In Fig. 14(b) a comparison is made between the consumptions of the compressors, keeping the H_2 pressure constant at -125°C . Under these plant conditions, the LD compressor consumption remains constant at 2524 kW, while the H_2 compressor varies in consumption depending on the storage pressure. Varying the H_2 storage pressure from 1.3 to 70 MPa results in a decrease in volume as it is inversely proportional to the pressure. It must be taken into account, however, that the decrease in volume is more significant between the pressures of 1.3 and 20 MPa and thus, if the H_2 pressure is further increased, so is the energy consumption, but the volume barely changes.

The study of both cases had led to the observation that the ideal working situation of the system is the point where the H_2 compressor power curve is cut (8.867 MPa) and that corresponding to its specific volume ($0.13\text{ m}^3/\text{kg}$) in Fig. 14(b). This point has been selected because, from observation, the storage volume is barely reduced while the H_2 compressor power increases considerably.

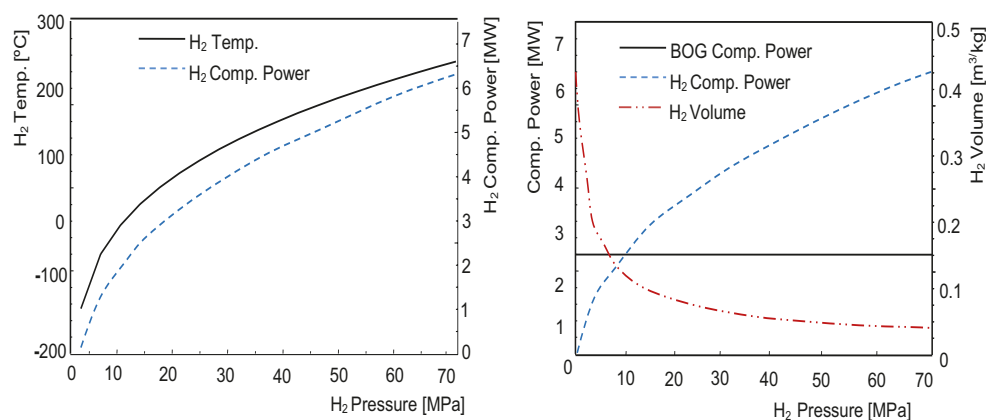

Fig. 14. Effect of H_2 pressure variation: (a) Comparison of H_2 temperature, H_2 pressure and compressor power; (b) Comparison of H_2 pressure and compressor work

HYDROGEN USAGE ON BOARD

Once stored H_2 is available on board, it needs to be consumed in the propulsion system or auxiliary equipment. The use of H_2 as fuel has two clear advantages: The main advantage is that there are no contaminating emissions, enabling the vessel to navigate in areas with stringent anti-pollution regulations such as ECAs [7, 16, 24] and also in port stays, not requiring shore-to-ship power (cold ironing) and so avoiding this large expense [24]. The second advantage to be highlighted is that internal combustion engines are a widely developed technology and can reliably consume hydrogen with minor modifications to the fuel and control system [29, 31, 39].

Using H_2 as fuel features various characteristics that considerably differentiate it from other fuels. With internal combustion engines, especially reciprocating engines, decreasing the power is a factor to be taken into account since the energy content per unit volume of H_2 is lower than that of other fuels [29]. This is because its low density reduces the space available in the cylinder or combustion chamber for the intake of air, reducing its power by up to 15%. To avoid this problem it is recommended to inject the hydrogen in a liquefied or pressurised state [29, 39].

When H_2 is consumed in the engines, its low self-igniting temperature presents a serious safety risk as the mixture could self-ignite [29]. It is for this reason that hot spots should be prevented from forming, as these can cause the mixture to ignite prematurely, generating knocking effects and shortening the life of the engine. To avoid this problem, hydrogen can be injected in a liquid state, since its low temperature prevents pre-ignition, or the injection of hydrogen into the cylinder can be delayed [31].

In order to burn 100% of H_2 in natural gas engines, the injection system must be modified, with three possibilities to highlight. The first option is called central injection, in which

the system has a carburettor to perform the mixture of air and H_2 . This system enables working with relatively low injection pressures, but the main drawbacks are the possible and easy pre-igniting of the fuel, and irregular combustion [31].

The second option is injection by means of gas valves, in which the H_2 is directly supplied moments after beginning the intake cycle. The probability and magnitude of the effects of pre-ignition are reduced with this system, but the main disadvantage is the high injection pressures [29, 36].

Direct injection is the third option and the one that can best be adapted to the vessel because of its similarity to the existing system. Injection would be performed during the compression cycle while the intake valve is closed, achieving a homogeneous mixture between the air and the H_2 . Pre-ignition is avoided with this system, and the engine power increases, but the drawback lies in the fact that the injection pressure is high in comparison with the other systems [29, 39].

Table 4 lists the advantages and disadvantages of the different systems when adapting the engines to consume H_2 .

From the following assessment, it is concluded that the CH_4 - H_2 mixture is the most viable system because no modification is required and polluting emissions are less.

Tab. 4. Advantages and disadvantages of adaptation systems for the consumption of H₂ in the engines

System	Advantages	Disadvantages
70%CH ₄ -30%H ₂ mixture	No fuel system modifications required	Emissions are not completely reduced
	Less polluting emissions	
Central injection	Low pressure	Pre-ignition
		Irregular combustion
Gas valve injection	The possibility of pre-ignition is reduced	Higher injection pressure
Direct injection	Pre-ignition is avoided	Extremely high injection pressure
	Increased engine power	

The model vessel used during the study comprises a propulsion system using DF engines with the option of consuming liquid and gas fuels. DF engines do not require any modifications to the injection system in order to consume the stored H₂, because they can run on a blend with the proportion of 70% CH₄ and 30% H₂ in molar base [34].

There is currently a fuel called Hythane comprising a mixture of 80% CH₄ and 20% H₂, which is designed to be used by natural gas engines, reducing hydrocarbon, CO and CO₂ emissions [20, 34, 36].

The data obtained from the conventional gas management plant on board the LNG vessel along with the results of the reforming study in [4] are used to calculate the autonomy and the polluting emissions of a vessel burning a mixture of 70% CH₄ and 30% H₂.

An LNG vessel with the characteristics specified in Table 2 generates 228 m³/day of BOG, of which 182 m³/day are used in the propulsion plant, and the excess 46 m³/day is sent to the reforming plant to generate H₂. The steam reforming plant generates 0.37 kg/s of H₂ for each kg/s of BOG [4]. Thus, if 46 m³/day of LNG is available, a total of 6836.225 m³/day of H₂ can be obtained at 25°C at 1.3 MPa.

If a mixture of 70% CH₄ and 30% H₂ is taken as reference to power the engines, 161.28 m³/day of LNG is needed and 3459.29 m³/day of H₂ in gas state. As can be seen, when H₂ is used as fuel, the amount of CH₄ required considerably decreases. This implies that the excess BOG increases and therefore more CH₄ is available which can be used in the H₂ generation plant. Table 5 depicts the values of consumption, autonomy and CO₂ emission reduction. It is important to highlight that with the implementation of the system, for each day that the reforming plant is in operation, enough H₂ is generated to supply power for almost 3 days and engine consumption decreases by 11.38%. This demonstrates that the system is energetically feasible and allows for greater versatility.

Tab. 5. Main parameters and assumptions for autonomy and emission analysis

System	Parameters	Value	Conditions
LNG tanks	BOG generation	228 m ³ /day	1 bar, -163°C

System	Parameters	Value	Conditions
Engine	Engine fuel: CH ₄		
	BOG consumed	182 m ³ /day	1 bar, -163°C
		0.894 kg/s	
	Engine fuel: mixture 70%CH ₄ -30%H ₂		
	BOG consumed	161.28 m ³ /day	1 bar, -163°C
		0.793 kg/s	
H ₂ consumed	3459.29 m ³ /day	13 bar, 25°C	
	0.042 kg/s		
CH ₄ fuel saved	11.38%		
Reforming	BOG for H ₂ generation	66.72 m ³ /day	1 bar, -163°C
	H ₂ generation per kg/s of CH ₄	0.370 kg/s	1 bar, 25°C
	H ₂ produced per day	10189.625 m ³ /day	13 bar, 25°C
Autonomy with 70%CH ₄ -30%H ₂	Per operation day of the reforming plant	2.94 days	
Emissions	CO ₂ reduction	11.38%	

CONCLUSIONS

Management of the BOG generated on board LNG vessels needs to be improved in order to optimise energy use. To this end, new systems that process the excess BOG generated on board, which is usually burned in the GCU without utilising its energy, need to be developed. Installing a reforming plant to obtain H₂ supports the optimum utilisation of the excess of BOG that is burned in the GCU, obtaining a fuel which is high in energy content and null in ozone-depleting emissions. The availability of H₂ on board thus leads to a need to store it on board, so that it can be subsequently consumed during navigation, thereby reducing CO₂ and SO_x emissions. An alternative H₂ storage system is proposed in this paper so that the H₂ can be used later in the propulsion system.

The analysis performed has led to the following conclusions:

- The storage of pressurised and cooled hydrogen in concentric tanks is a system that provides simplicity, maturity, low cost and safety in comparison with other systems, making it the most suitable method for LNG vessels.
- The availability of a low-temperature source as is LNG at -163°C facilitates the cooling of the hydrogen, reducing the storage volume by 85% and the power required by the compressors by 45%.
- Introducing hydrogen into the storage tanks at a temperature of 25°C would only affect the daily formation of BOG by 0.0075%.
- DF engines support a mixture of 70% CH₄ and 30% H₂ as fuel, without requiring any modifications to the injection system.
- Each day of operation of the reforming plant can generate enough H₂ for an autonomy of almost 3 days, and engine consumption decreases by 11.38%.
- Pollutant emissions are reduced in relation to the amount of CH₄ used, as it is the only component that is associated with its carbon composition.

In view of the above, the generation, storage and subsequent consumption of hydrogen in LNG propulsion plants is an energy-viable option, reducing ozone-depleting emissions whilst offering increased versatility to the vessel.

REFERENCES

- Aguilera R. F., Aguilera R. (2012): *World natural gas endowment as a bridge towards zero carbon emissions*. Technol. Forecast Soc. Change, 79(3), 579-86.
- Air Liquide, www.airliquide.com [accessed 20.11.16].
- Arias Fernández I., Romero Gómez M., Baaliña Insua A. (2017): *Review of propulsion systems on LNG carriers*. Renewable and Sustainable Energy Reviews, 67, 1395-1411.
- Arias Fernández I., Romero Gómez M., Romero Gómez J., López-González L. M. (2017): *H₂ production by the steam reforming of excess boil off gas on LNG vessels*. Energy Conversion and Management, 134(February), 301-313.
- Belz S. (2016): *A synergetic use of hydrogen and fuel cells in human spaceflight power systems*. Acta Astronautica, 121, 323-331.
- Burel F., Taccani R., Zuliani N. (2013): *Improving sustainability of maritime transport through utilization of Liquefied Natural Gas (LNG) for propulsion*. Energy, 57, 412-420.
- Chang D., Rhee T., Nam K., Chang K., Lee D., Jeong S. (2008): *A study on availability and safety of new propulsion systems for LNG carriers*. Reliab. Eng. Syst. Saf., 93(12), 1877-85.
- Lin C.-Y. (2013): *Strategies for promoting biodiesel use in marine vessels*. Marine Policy, 40, 84-90.
- Chilev C., Darkrim Lamari F. (2016): *Hydrogen storage at low temperature and high pressure for application in automobile manufacturing*. International Journal of Hydrogen Energy, 41, 1744-1758
- Rao D., Wang Y., Meng Z., Yao S., Chen X., Shen X., Lu R. (2015): *Theoretical study of H₂ adsorption on metal-doped graphene sheets with nitrogen-substituted defects*. International Journal of Hydrogen Energy, 40, 14154-14162.
- Dincer I., Canan A. (2015): *Review and evaluation of hydrogen production methods for better sustainability*. International Journal of Hydrogen Energy, 40, 11094-11111.
- Dincer I. (2012): *Green methods for hydrogen production*. International Journal of Hydrogen Energy, 37, 1954-1971.
- Yeo D., Ahn B., Kim J., Kim I. *Propulsion alternatives for modern LNG carriers*. Samsung Heavy Industries Co., Ltd., Paper PS6-S.
- Dobrota D., Lalić B., Komar I. (2013): *Problem of Boil-off in LNG Supply Chain*. Regular papers, Transactions on Maritime Science, 02, 91-100.
- Sciberras E. A., Zahawi B., Atkinson D. J. (2015): *Electrical characteristics of cold ironing energy supply for berthed ships*. Transportation Research Part D, 39, 31-43.
- Attah E. E., Bucknall R. (2015): *An analysis of the energy efficiency of LNG ships power in options using the EEDI*. Ocean Engineering, 110, 62-74.
- Exxonmobil, www.corporate.exxonmobil.com [accessed 20.11.16].
- Omar F., Szpunar J. A., Szpunar B., Beye A. C. (2016): *Hydrogen adsorption and storage on palladium – functionalized graphene with NH-dopant: A first principles calculation*. Applied Surface Science, Available online September 2016
- Gas Natural Fenosa, www.gasnaturalfenosa.com [accessed 19.11.16].
- Gutiérrez J. L. (2005): *El hidrógeno, combustible del futuro*. Rev. R. Acad. Cienc. Exact. Fís. Nat. (Esp), 99(1), 49-67. V Programa de Promoción de la Cultura Científica y Tecnológica.
- Lindstad H., Sandaas I., Strømman A. H. (2015): *Assessment of cost as a function of abatement options in maritime emission control areas*. Transportation Research Part D, 38, 41-48.
- Xiao J., Zhou T., Cossement D., Bénard P., Chahine R. (2013): *Coupled thermal simulation of hydrogen storage tank-Dewar flask system*. International Journal of Hydrogen Energy, 38(25), 10880-88.
- Fagerholt K., Gausel N. T., Rakke J. G., Psaraftis H. N. (2015): *Maritime routing and speed optimization with emission control areas*. Transportation Research Part C, 52, 57-73.
- Klein S. A. (2012): *Engineering Equation Solver (EES)*; 2012 Academic Professional V9.172.
- Kumar S., Kwon H., Choi K., Hyun Cho J., Lim W., Moon I. (2011): *Current status and future projections of LNG demand and supplies: A global prospective*. Energy Policy, 39(7), 4097-104.
- Linde Group www.linde.com [accessed 02.11.16].

27. Maxwell D., Zhu Z. (2011): *Natural gas prices, LNG transport costs, and the dynamics of LNG imports*. Energy Econ., 33(2), 217-26.
28. ME-GI Dual Fuel MAN B&W Engines. A Technical, Operational and Cost-effective Solution for Ships Fuelled by Gas. <http://goo.gl/caO0k1> [accessed 19.11.16].
29. Mitsubishi Heavy Industries, www.mhi-global.com [accessed 23.11.16].
30. MAN (Marine Engines and Systems), www.marine.man.eu [accessed 23.11.16].
31. Rusman N. A. A., Dahari M. (2016): *A review on the current progress of metal hydrides material for solid-state hydrogen storage applications*. International Journal of Hydrogen Energy, 41, 12108-12126.
32. Reguera E. (2009): *Hydrogen Storage Nanocavities*. Rev. Cub. Física, 26, 3-14.
33. Repsol. www.repsol.com [accessed 19.11.16].
34. Romero Gómez J., Romero Gómez M., Lopez Bernal J., Baaliña Insua A. (2015): *Analysis and efficiency enhancement of a boil-off gas reliquefaction system with cascade cycle on board LNG carriers*. Energy Convers. Manage., 94,261-74.
35. Samsung Techwin, www.samsungtechwin.com [accessed 20.11.16]
36. Sinha R. P., Nik W. M. N. W. (2011): *Investigation of propulsion system for large LNG ships*. 1st International Conference on Mechanical Engineering Research (ICMER2011)
37. U.S. Energy Information Administration, *Annual Energy Outlook 2014*.
38. Wartsila. www.wartsila.com [accessed 19.11.16].
39. Yeo D., Ahn B., Kim J., Kim I. (2007): *Propulsion alternatives for modern LNG carriers*. In: Gas Technology Institute - 15th International Conference and Exhibition on Liquefied Natural Gas 2007, LNG 15 GNL 15, 620-35.
40. Yu Y. H., Kim B. G., Lee D. G. (2013): *Cryogenic reliability of the sandwich insulation board for LNG ship*. Composite Structures, 95, 547-556, ISSN 0263-8223.
41. Shin Y. G., Lee Y. P. (2009): *Design of a boil-off natural gas reliquefaction control system for LNG carriers*. Applied Energy, 86(1), 37-44, ISSN 0306-2619.
42. Fan Z., Zhao P., Niu M., Maddy J. (2016): *The survey of key technologies in hydrogen energy storage*. International Journal of Hydrogen Energy, 41, 14535-4552.

CONTACT WITH THE AUTHORS

Ignacio Arias Fernández

e-mail: ignacio.arias@udc.es

University of A Coruña – Energy Engineering Research Group – School of Nautical Science and Marine Engineering,
c/Paseo de Ronda, 51, 15011 A Coruña,
SPAIN

Manuel Romero Gómez

e-mail: m.romero.gomez@udc.es

University of A Coruña – Energy Engineering Research Group – School of Nautical Science and Marine Engineering,
c/Paseo de Ronda, 51, 15011 A Coruña,
SPAIN

Javier Romero Gómez

e-mail: j.romero.gomez@udc.es

University of A Coruña – Energy Engineering Research Group – School of Nautical Science and Marine Engineering,
c/Paseo de Ronda, 51, 15011 A Coruña,
SPAIN

Luis M. López-González

e-mail: luis-maria.lopez@unirioja.es

Department of Mechanical Engineering,
University of La Rioja,
C/Luís de Ulloa, 20, 26004 Logroño,
SPAIN