

NEW DESIGNS OF MAGNETIC FLUID SEALS FOR RECIPROCATING MOTION

Leszek Matuszewski*

Piotr Bela

Gdańsk University of Technology, Poland

* Corresponding author: leszekma@pg.edu.pl

ABSTRACT

The operating conditions of magnetic fluid seals during reciprocating motion are so different from those observed in rotating motion that the use of their conventional structures for reciprocating motion seals yields no good results. The analysis of the sealing mechanism of magnetic fluid seals in reciprocating motion shows that the operation of these seals is affected by the carry-over phenomenon and magnetic fluid film deformation in the sealing gap, which depends on the velocity of the reciprocating motion. The reduced amount of magnetic fluid in the sealing gap caused by the reciprocating motion of the shaft is the main reason for seal failures.

The paper presents a short characterisation of magnetic fluid sealing technology, the principle of sealing, the operation of the magnetic fluid and the seal failure mechanism in linear motion of the shaft. Moreover, some new structural designs of hybrid seals, being combinations of typical hydraulic seals with magnetic fluid seals for reciprocating motion, and some examples of magnetic fluid sealing structures for hydraulic cylinders and piston compressors which have practical application values are presented.

Keywords: magnetic fluid seal, reciprocating motion, critical pressure, sealing mechanism, failure reason of the seal, new seal designs

INTRODUCTION

At present, magnetic fluid sealing is the most important industrial application of magnetic fluid technology developed mainly in the last two decades. Magnetic fluids (ferrofluids) consist of the colloidal suspension of submicron size magnetic particles (e.g. Fe_3O_4 – magnetite) in various fluids used as carrier liquids. In the simplest form, a magnetic fluid seal consists of a pair of magnetically permeable pole pieces separated by an axially polarised permanent magnet and the ferrofluid. The flux lines formed in the closed magnetic circuit concentrate the ferrofluid in radial sealing gaps between the shaft and the pole pieces, thus producing a seal with virtually immeasurable leakage, low viscous drag and no contact wear.

Magnetic fluid seals offer high reliability and cost-effective solutions to many difficult sealing problems in modern machinery and processing equipment, especially in rotating motion in high vacuum and low-pressure gas applications.

These seals can also be used for reciprocating motion with low linear velocity e.g. in vacuum linear feedthroughs, hydraulic cylinders and reciprocating compressors [1, 2, 5].

Conventional ferrofluid rotary shaft apparatus are not satisfactory when the shaft must perform linear motion, since the ferrofluid gets displaced along the shaft during linear motion of the shaft resulting in the ultimate failure of the seal.

In order to overcome these disadvantages and improve the seal life, a newly designed sealing structure are used, that prevent the deformation of the magnetic fluid film and reduce the loss of magnetic fluid in the sealing gap.

ANALYSIS OF THE SEALING MECHANISM IN RECIPROCATING MOTION

The operating conditions of magnetic fluid seals during reciprocating motion are so different from those with rotating motion, that the use of their conventional structures for

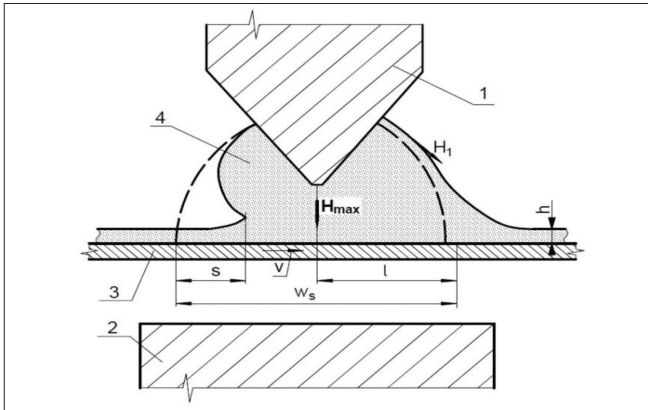

Fig. 1. Study of the carry-over phenomenon and magnetic fluid seal deformation: 1, 2 – rod-like pole pieces, 3 – disk, 4 – magnetic fluid

reciprocating motion seals yield no good results. Analysis of sealing mechanism of the magnetic fluid seal in reciprocating motion shows that the operation of these seals is affected by the carry-over and the magnetic fluid deformation in the sealing gap, which depends on the velocity of reciprocating motion. The reduction of magnetic fluid quantity in the sealing gap, caused by the reciprocating motion of the shaft is main reason of the seal failure.

One of the basic parameters of magnetic fluid seal is critical pressure. It is the maximum operating pressure of the magnetic fluid seal. In the case increase of the pressure in the seal above the critical pressure, the continuity of the fluid sealing ring is disrupted.

The study of magnetic fluid carry-over [3, 4] is made using an experimental model with the rod-like pole pieces 1 and 2 (Fig. 1). The peripheral part of disk 3 coming into the gap between the pole pieces moves at a speed v during its motion. Magnetic fluid 4 fills the sealing gap between pole piece 1 and disk 3.

The experimental apparatus made it possible to model the operation of a one-tooth magnetic fluid seal in linear shaft motion without pressure difference. The magnetic forces operating along the length l of the magnetic fluid seal affect the formation of the film carried away. The results have shown that the thickness h of the magnetic fluid film carried away by

the shaft increases with the increasing speed v and dynamic viscosity η , which can lead to magnetic fluid seal failure. The increase of the magnetic field gradient decreases h by several times, but it does not eliminate the carry-over completely.

The seal deformation changes the magnetic field intensity H values on its free surfaces which leads to the dependence of the critical pressure drop $\Delta p_{CR,1}$ upon the shaft motion direction. Fig. 2a shows the magnetic fluid position and Fig. 2b – the magnetic field intensity distribution H under magnetic fluid seal stage in the reciprocating motion. With allowance for the above stated assumption and with the stationary shaft:

$$\Delta p_{CR,1} = \mu_0 M_s (H_1 - H_2) \quad (1)$$

where:

- μ_0 – vacuum magnetic permeability,
- M_s – saturation magnetization of magnetic fluid,
- H_1 – magnetic field intensity in the point A at stationary shaft,
- H_2 – magnetic field intensity in the point D at stationary shaft

When the shaft moves one way with the external pressure difference or opposing it, the critical pressure drop $\Delta p_{CR,1}$ will accordingly be:

$$\Delta p_{CR,1} \rightarrow = \mu_0 M_s (H_B - H_2), \quad (2a)$$

$$\Delta p_{CR,1} \leftarrow = \mu_0 M_s (H_1 - H_C), \quad (2a)$$

where:

- H_B – magnetic field intensity in point B at stationary shaft.
- H_C – magnetic field intensity in point C at stationary shaft.

The sign with arrows \rightarrow means movement in line with the pressure gradient and in opposite direction.

Due to distribution under the stage the decrease of $\Delta p_{CR,1} \rightarrow$ will be more substantial than $\Delta p_{CR,1} \leftarrow$. The comparison of values of $\Delta p_{CR,1}$ calculated according to (2a) and (2b) with the results of experimental study of magnetic fluid seal of conventional type shows that at the pressure

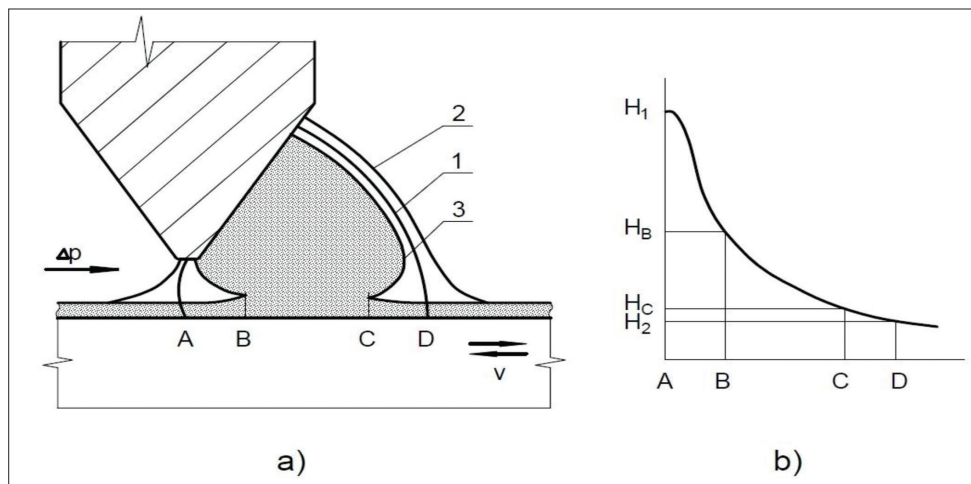

Fig. 2. Magnetic fluid position (a) and magnetic field intensity distribution H (b) under the magnetic fluid seal stage: 1 – stationary shaft, 2 – shaft moving in the direction of pressure gradient Δp , 3 – shaft moving in the direction opposite to pressure gradient Δp

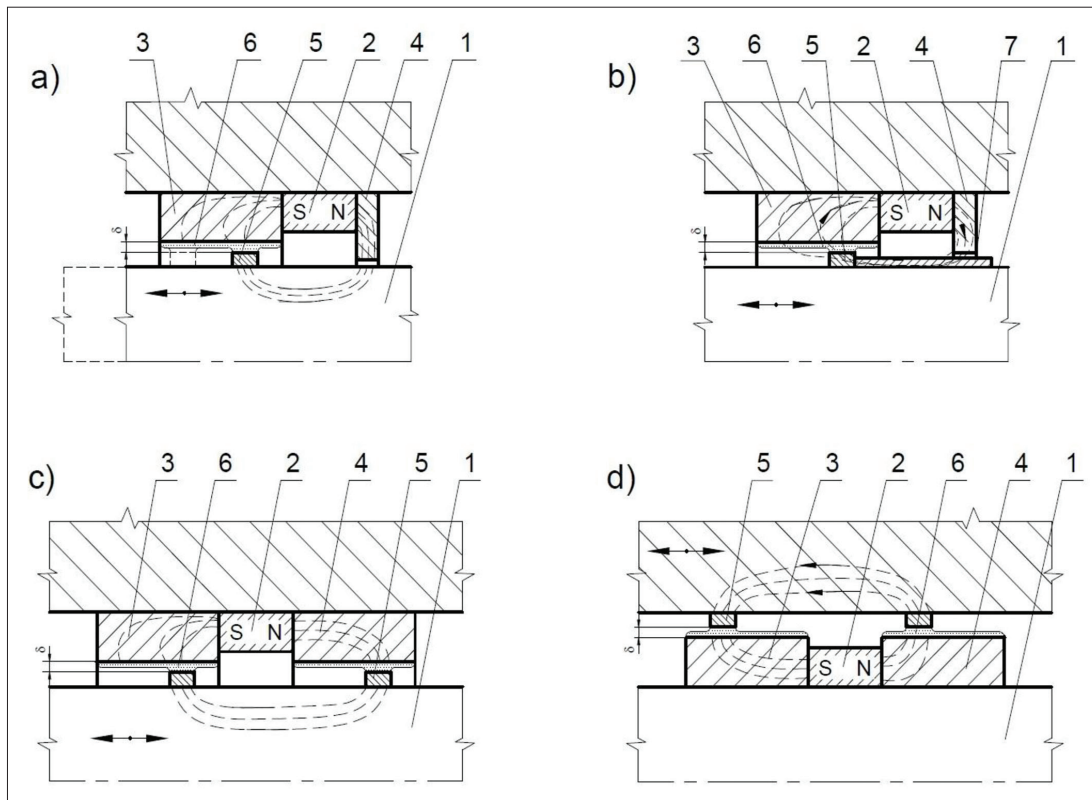

Fig. 3. Basic configurations of magnetic fluid seal for linear motion. From a to d – variants of seal design 1 – piston rod, 2 – axially polarised permanent magnet, 3, 4 – pole pieces, 5 – annular ring, 6 – magnetic fluid (ferrofluid), 7 – magnetically permeable sleeve

difference $\Delta p < \Delta p_{CR,1} \Rightarrow$ good hermetic sealing is ensured; at $\Delta p_{CR,1} \Rightarrow \Delta p < \Delta p_{CR,1} \Leftarrow$ temporary micro punctures affect the tightness; and $\Delta p \geq \Delta p_{CR,1} \Leftarrow$ causes complete seal failure. Thus, the seal deformation is the principal cause of the decrease of tightness and the critical pressure differences of magnetic fluid seal in reciprocating motion of the shaft.

BASIC CONFIGURATIONS OF MAGNETIC FLUID SEAL FOR LINEAR MOTION

Fig. 3 shows a basic configuration of the magnetic fluid seal that is particularly useful as a hermetic seal of a shaft arranged relatively for linear reciprocating motion [6]. In the seal configuration shown in Fig. 3a, the axially polarised annular permanent magnet 2 is fixed within a bore of the housing. Pole pieces 3, 4 are press-fitted within the housing at both sides of the magnet. Pole piece 3 has a cylindrical inner face that is coaxial with and spaced from shaft 1. The inner face of this pole has an axial length equal to or greater than the stroke of the reciprocating movement of the shaft. The axial and radial dimensions of pole piece 4 are such that it closely faces the shaft 1 in a spaced relationship to form part of the magnetic flux circuit, generated by magnet 2. An annular ring 5 made of magnetically permeable material is hermetically press-fitted around shaft 1. As shown, the axial length of ring 5 is smaller than that of pole piece 3. The radial diameters of the outer face of ring 5 and the inner face of pole piece 3 are selected in such a way that a small radial gap δ is formed between them. The magnetic flux generated by magnet 2 forms a closed magnetic circuit, as schematically

shown by the dotted lines. The magnetic fluid 6 is magnetically retained in the gap δ to provide a hermetic seal between pole piece 3 and ring 5. As shaft 1 performs a linear motion together with ring 5, the inner portion of the magnetic fluid 6 follows the linear movement of the ring. Since the axial length of pole piece 3 is equal to or greater than the stroke of linear movement of shaft 1, the inner portion of the magnetic fluid 6 is constantly in contact with the ferrofluid film, and a hermetic seal is established during the linear motion. Fig. 3b shows the seal configuration designed for use with a magnetically non-permeable shaft. In this case, the sleeve 7 made of magnetically permeable material is fitted over shaft 1, and adheres to ring 5. Thus, the magnetic flux circuit is completed to magnetically retain the magnetic fluid 6 in the gap δ . The seal configuration shown in Fig. 3c is designed to perform a hermetic seal in two stages. In this case, two pole pieces have an axial length equal to or larger than the linear stroke of shaft 1, and a second ring 5 is press-fitted over the shaft to form the second gap δ in which the magnetic fluid 6 is retained. The seal configuration shown in Fig. 3d is designed to be used together with a magnetically permeable housing. An axially polarised annular magnet 2 is fitted over shaft 1 and sandwiched between magnetically permeable pole pieces 3, 4, which are hermetically press-fitted over the shaft. The annular rings 5 are hermetically press-fitted within a bore of the housing situated opposite pole pieces 3, 4. The magnetic fluid 6 is retained in the gaps δ , to provide a pair of hermetic seals between the shaft and the housing. This seal apparatus may be advantageously employed in places where the housing undergoes linear reciprocating movement.

SOME NEW DESIGNS OF COMBINED FLUID SEALS FOR RECIPROCATING MOTION REVIEW

Below are presented some new designs of hybrid seals of elements for reciprocating motion, being combinations of typical hydraulic seals with magnetic fluid seals. Fig. 4 shows a hybrid seal for large-size elements of reciprocating and rotating motion [7]. A characteristic structural feature of this seal is that two sealing units, separated by an axially polarised annual permanent magnet 4, are mounted in the gland chamber of housing 2. Each unit consists of the support sleeve 3 with single asymmetric pole pieces 5 and non-magnetic spacers 7 alternately fixed in cylindrical bore chambers 3b of support sleeves 3. Moreover, non-magnetic spacers 7 and soft sealing rings 8 of rectangular cross-section, made of braided packing rope, for instance, are mounted on both ends of each sealing package. The sealing projection in each single asymmetric pole piece 5 is determined by the conical surface of its inner opening. In each sealing package, single asymmetric pole pieces 5 are directed with their sealing surfaces toward the annual permanent magnet 4. An additional single soft sealing ring 8 of rectangular cross-section is mounted between the inner side surfaces of flanges 3a of support sleeves 3, the cylindrical surface of the annular permanent magnet 4, and the piston rod 1. The gland chamber is closed from both sides of housing 2 by pressure glands 10, in which plain bearing bushings 11 adhering to the surface of piston rod 1 are mounted. The magnetic fluid 6 is retained in the annular sealing gaps δ created between the sealing projections of single asymmetric pole pieces 5 and the surface of piston rod 1. Closed magnetic circuits $\Phi_1, \Phi_2, \Phi_3, \Phi_4$ are created by annular permanent magnet 4, support sleeves 3, single asymmetric pole pieces 5, magnetic fluid 6, and piston rod 1.

Fig. 5 shows another hybrid seal for large-size elements of reciprocating and rotating motion [8]. In the central part of this seal, in housing 2, the sealing unit consisting of two asymmetric multi-edge pole pieces 4 separated by axially polarised annular permanent magnet 3 is mounted. Other sealing sub-assemblies are mounted on both ends of this seal, each sub-assembly consisting of at least three symmetric multi-edge pole pieces 7 separated by axially polarised annular permanent magnets 5, 6 mounted in cylindrical bore chambers

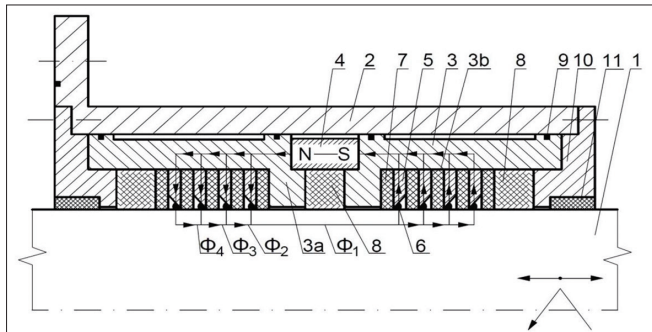

Fig. 4. Hybrid seal for large-size elements of reciprocating and rotating motion:
1 - piston rod or shaft, 2 - housing, 3 - support sleeve, 3a - flange, 3b - bore chamber, 4 - annular permanent magnet, 5 - single pole piece, 6 - magnetic fluid, 7 - non-magnetic spacer, 8 - soft sealing ring, 9 - "O"-ring seal, 10 - pressure gland, 11 - plain bearing bushing, δ - sealing gap, $\Phi_1 - \Phi_4$ - closed magnetic circuits

in pole pieces 7. Permanent magnets 5, 6 adhere with poles *N* to the side surfaces of the central symmetric multi-edge pole piece 7. Moreover, elastic pressure rings 9 of circular cross-section, made of elastomeric material, and pressure glands 10 made of low friction material and adhering to the surface of piston rod 1 are mounted in the annular chambers created between the side surfaces of symmetric multi-edge pole pieces 7 and the inner cylindrical surfaces of permanent magnets 5, 6. An additional soft sealing ring 11 is placed between the inner side surfaces of asymmetric multi-edge pole pieces 4, the inner cylindrical surface of permanent magnet 3, and the piston rod 1. Moreover, non-magnetic spacers 13 are placed on both ends of the sealing sub-assemblies, as well as between symmetric multi-edge pole pieces 7 and asymmetric multi-edge pole pieces 4. The magnetic fluid 8 is retained in the annular sealing gaps δ created between sealing projections situated on the inner cylindrical surfaces of symmetric multi-edge pole pieces 7 and asymmetric multi-edge pole pieces 4, and the surface of piston rod 1. Closed magnetic circuits Φ_1, Φ_2 are created by symmetric multi-edge pole pieces 7, permanent magnets 5, 6, magnetic fluid 8, and piston rod 1, while the closed magnetic circuit Φ_3 is created by permanent magnet 3, asymmetric multi-edge pole pieces 4, magnetic fluid 8, and piston rod 1.

Fig. 6 shows another patent pending (P-438268) design of hybrid seal for large-diameter elements of rotating or reciprocating motion [9]. In this design, two multi-edge pole pieces 3 having the form of flange bushes with sealing projections formed on the inner cylindrical surfaces of their flanges 3a are mounted in the gland chamber of housing 2. The pole pieces are separated by axially polarised annular permanent magnet 4. Moreover, two sealing packages, each consisting of soft sealing ring 9 of rectangular cross-section and at least two radially polarised permanent magnets 5, 6 separated by non-magnetic spacers 7, are mounted in bore chambers 3b of multi-edge pole pieces 3 situated at the side of piston rod 1. The adjacent permanent magnets 5, 6 have an alternating sequence of poles *N* and *S* with respect to piston rod 1, while the gland chamber is closed on both sides of housing 2 with pressure glands 11, in which porous sliding bearings 12 adhering to piston rod 1 are mounted. An additional soft sealing ring 9 of rectangular cross-section,

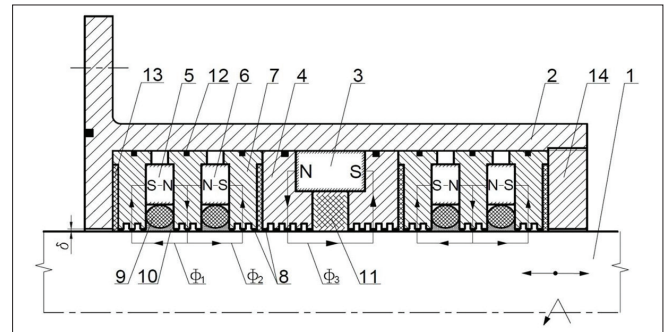

Fig. 5. Hybrid seal for large-size elements at rotating or reciprocating motion:
1 - shaft or piston rod, 2 - housing, 3, 5, 6 - axially polarised annular permanent magnets, 4 - multi-edge asymmetric pole piece, 7 - multi-edge symmetric pole piece, 8 - magnetic fluid, 9 - elastic pressure ring of circular section, 10 - sliding bushing, 11 - soft sealing ring, 12 - "O"-ring seal, 13 - non-magnetic spacer, 14 - nut, δ - sealing gap, Φ_1, Φ_2, Φ_3 - closed magnetic circuits

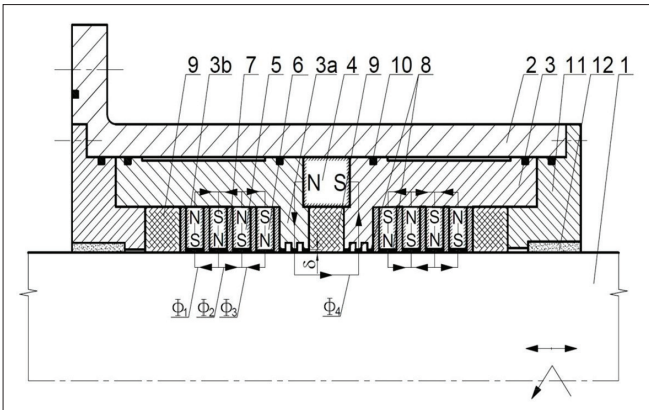

Fig. 6. Hybrid seal for large-diameter elements of rotating or reciprocating motion: 1 - shaft or piston rod, 2 - housing, 3 - multi-edge pole piece, 3a - flange, 3b - bore chamber, 4 - axially polarised permanent magnet, 5, 6 - radially polarised permanent magnets, 7 - non-magnetic spacer, 8 - magnetic fluid, 9 - soft sealing ring, 10 - "O"-ring seal, 11 - pressure gland, 12 - porous sliding bearing, δ - sealing gap, Φ_1, Φ_2, Φ_3 - closed magnetic circuits

made of braided packing rope for instance, is mounted between the inner facing surfaces of flanges 3a of multi-edge pole pieces 3, the inner cylindrical surface of axially polarised annular permanent magnet 4, and piston rod 1. The magnetic fluid 8 is retained in annular sealing gaps δ created between the sealing projections of multi-edge pole pieces 3 and the surface of piston rod 1, and between the inner cylindrical surfaces of the radially polarised permanent magnets 5, 6 mounted in bore chambers 3b of multi-edge pole pieces 3 and piston rod 1. The closed magnetic circuits Φ_1, Φ_2 , and Φ_3 are created by piston rod 1, radially polarised permanent magnets 5, 6, and magnetic fluid 8, while the closed magnetic circuit Φ_4 is created by axially polarised permanent magnet 4, multi-edge pole pieces 3, magnetic fluid 8, and piston rod 1.

Fig. 7 presents the patent pending (P-437268) combined design of a hybrid seal for large-diameter elements of rotating or reciprocating motion [10]. This design is composed of multi-edge pole pieces, an axially polarised annular permanent magnet, magnetic fluid, soft sealing rings, coil springs, back-up and pressure rings, pressure glands, and porous sliding bearings. The characteristic feature of this design is that two multi-edge pole pieces 3, having the form of flange bushes with sealing projections 3c formed on the inner cylindrical surfaces of their flanges 3a, are mounted in the gland chamber of housing 2 and separated by the axially polarised annular permanent magnet 4. Moreover, soft sealing rings 6 and sub-assemblies consisting of pressure rings 9, coil springs 8, and back-up rings 7 are mounted in bore chambers 3b of pole pieces 3 situated at the side of piston rod 1. These sub-assemblies are pressed from outside by pressure glands 10 with mounted porous sliding bearings 11 adhering to the surface of piston rod 1. An additional soft sealing ring 6, made of braided packing rope for instance, is placed in the chamber created between the inner facing surfaces of flanges 3a of multi-edge pole pieces 3, the permanent magnet 4, and the piston rod 1. The magnetic fluid 5 is retained in annular sealing gaps δ created between sealing projections 3c of multi-edge pole pieces 3 and the surface of piston rod 1. The closed magnetic circuit Φ is created by piston rod 1, multi-edge pole pieces 3, annular permanent magnet 4, and magnetic fluid 5.

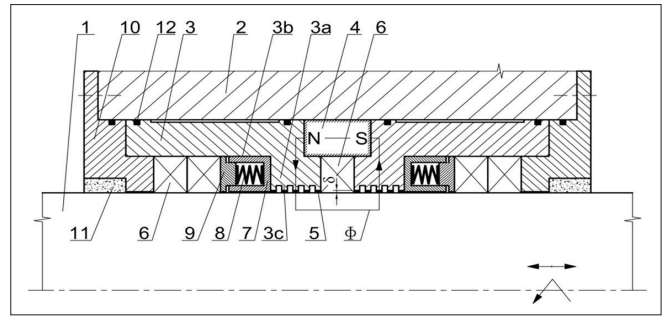

Fig. 7. Hybrid seal for large-size elements at rotating or reciprocating motion: 1 - shaft or piston rod, 2 - housing, 3 - multi-edge pole piece, 3a - flange, 3b - bore chamber, 3c - sealing projection, 4 - annular permanent magnet, 5 - magnetic fluid, 6 - soft sealing ring, 7 - back-up ring, 8 - coil spring, 9 - pressure ring, 10 - pressure gland, 11 - porous sliding bearing, 12 - "O"-ring seal, δ - sealing gap, Φ - closed magnetic circuit

Fig. 8 shows the patented (PL234946) solution of a hybrid seal for elements of rotating or reciprocating motion [11]. In this seal, two multi-edge pole pieces 3 having the form of flange bushes with sealing projections made on the cylindrical surfaces of their flanges 3a are mounted in the gland chamber of housing 2 and separated by axially polarised annular permanent magnet 4. Moreover, two sealing packages, each consisting of soft sealing ring 7 of rectangular cross-section and permanent magnet 5 of "C"-shaped cross-section are placed in bore chambers 3b of multi-edge pole pieces 3 situated at the side of piston rod 1. The arms of permanent magnet 5 directed towards the surface of piston rod 1 are the poles N and S. An elastic sealing ring 8 of circular cross-section is placed, together with back-up rings 9, at the inner side of permanent magnet 5, between poles N and S. The gland chamber is closed on both sides of housing 2 by pressure glands 12 with mounted porous sliding bearings 13 adhering to the surface of piston rod 1. Moreover, a single soft sealing ring 7 of rectangular cross-section, made of braided packing rope for instance, is placed between the inner facing surfaces of flanges 3a of multi-edge pole pieces 3, the cylindrical surface of axially polarised permanent magnet 4 and piston rod 1. The magnetic fluid 6 is retained in annular sealing gaps δ created between the sealing projections of multi-edge pole pieces 3 and the

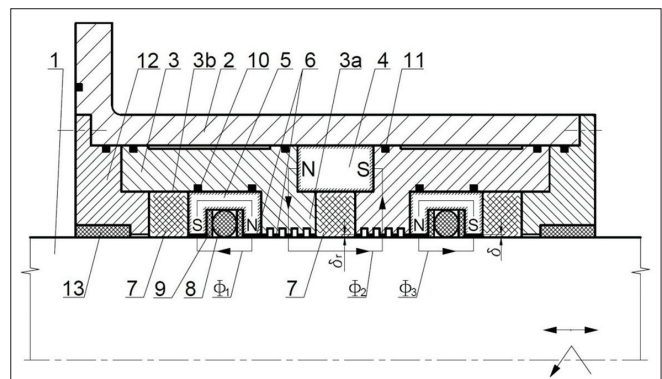

Fig. 8. Hybrid seal for elements of reciprocating or rotating motion: 1 - piston rod or shaft, 2 - housing, 3 - multi-edge pole piece, 3a - flange, 3b - bore chamber, 4 - axially polarised annular permanent magnet, 5 - permanent magnet of "C"-shaped cross-section, 6 - magnetic fluid, 7 - soft sealing ring, 8 - elastic sealing ring of circular cross-section, 9 - back-up ring, 10, 11 - "O"-ring seals, 12 - pressure gland, 13 - porous sliding bearing, δ - sealing gap, $\Phi, \Phi_1, \Phi_2, \Phi_3$ - closed magnetic circuits

surface of piston rod 1, and between the cylindrical surfaces of the arms composing the poles N and S of permanent magnets 5 of “C”-shaped cross-section and the surface of piston rod 1. Closed magnetic circuits Φ_1 and Φ_3 are created by permanent magnets 5 of “C”-shaped cross-section, piston rod 1, and magnetic fluid 6, while the closed magnetic circuit Φ_2 is created by multi-edge pole pieces 3, axially polarised annular permanent magnet 4, piston rod 1, and magnetic fluid 6.

APPLICATION EXAMPLES OF MAGNETIC FLUID RECIPROCATING SEALING

Fig. 9 shows two variants of combined types of the magneto-fluid reciprocating sealing structure for hydraulic cylinders. Fig. 9a shows a patented (Int.CL.F16J15/43 no 109505985) reciprocating sealing device with magnetic fluid for the hydraulic cylinder [12], which comprises a cylinder shell 2, multi-edge pole pieces 3, axially polarised permanent magnet rings 4, non-magnetic conductive rings 5, magnetic fluid 6 and distance magnetic isolation rings 7. According to the principle of operation of the reciprocating sealing device with magnetic fluid for the hydraulic cylinder, the magnetic source is provided by multiple permanent magnets, while the non-magnetic conductive rings are arranged in the space formed by pole pieces 3, permanent magnets 4 and piston rod 1 in the enclosing mode. The non-magnetic conductive rings 5 are provided with pole teeth; therefore, the problem of the pressure resistance of the existing single-magnetic-source magnetic fluid sealing device and the existing multi-magnetic-source magnetic fluid sealing device is solved, along with the problem of the magnetic fluid utilisation rate of an existing magnetic fluid sealing device. Fig. 9b shows a combined magnetic fluid reciprocating sealing structure (Patent CN, In.CL. F16J15/43, no 108869751) [13], which has a plurality of annular multi-edge pole pieces 3 axially arranged at intervals inside the space between the outer surface of piston rod 1 and the inner surface of cylinder shell 2. The inner cylindrical surface of each pole piece is provided with pole teeth. The axially magnetised permanent magnet rings 4 are clamped between every two neighboring pole pieces 3, which are opposite in magnetic polarity. The sealing gaps δ created between the pole teeth and the outer surface of piston rod 1 are filled with magnetic fluid 7. An annular accommodating space is formed between the inner spherical surface of each axially magnetised permanent magnet ring 4 and the outer surface of piston rod 1. This space is closed with double acting seals in which sliding rings 6, made of low friction material, are energised by elastomeric “O”-rings 5. In this case the “O”-rings 5 preload the sliding rings 6 in the thin flexible middle section. In both seal designs closed magnetic circuits Φ are created by multi-edge pole pieces 3, permanent magnets 4, magnetic fluid 5 and piston rod 1. The combined magnetic fluid reciprocating sealing structure created by adding double-acting seals into the traditional magnetic fluid sealing design can further enhance the sealing and press-resistant performance and eliminate the loss of magnetic fluid.

Fig. 10 shows the magnetic fluid sealing structure for reciprocating motion used in hydraulic cylinders [14]. The

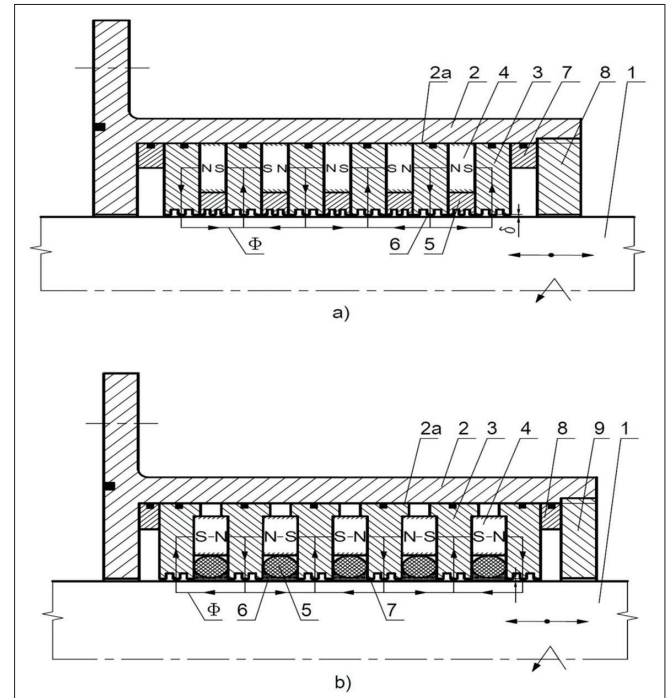

Fig. 9. Combined types of magneto-fluid reciprocating sealing structure for hydraulic cylinder a), b) design variants: a) 1 - piston rod, 2 - cylinder shell, 2a - bore chamber, 3 - multi-edge pole piece, 4 - axially polarised permanent magnet ring, 5 - non-magnetic conductive ring, 6 - magnetic fluid, 7 - distance magnetic isolation ring, 8 - nut, δ - sealing gap, Φ - closed magnetic circuit b) 1 - piston rod, 2 - cylinder shell, 2a - bore chamber, 3 - multi-edge pole piece, 4 - axially polarised permanent magnet ring, 5 - elastomeric “O”-ring, 6 - sliding ring, 7 - magnetic fluid, 8 - distance ring, 9 - nut, δ - sealing gap, Φ - closed magnetic circuit

magnetic fluid sealing structure comprises the cylinder shell 2, the reciprocating piston rod 1 arranged in the inner cavity of the shell, multi-edge pole pieces 3, 4 and axially polarised permanent magnets 5, 6. The multi-edge pole pieces 3, 4 are arranged on the two sides of each permanent magnet 5, 6. At least one groove is formed around the inner circle face of each pole piece 3, 4 and a Y-shaped sealing ring 8 is arranged in each groove. Pole teeth are arranged on the inner circle faces of the pole pieces 3, 4. The sealing gaps δ exist between the pole teeth and the outer surface of the reciprocating piston rod 1. The magnetic fluid 7 is injected into gap positions. Two closed magnetic circuits Φ_1 , Φ_2 are created by multi-edge pole

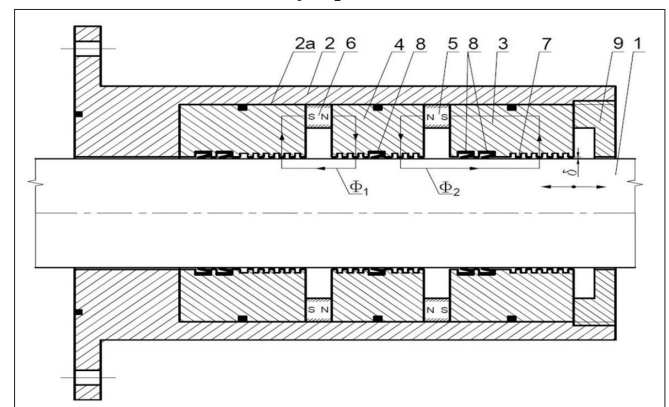

Fig. 10. Magnetic fluid sealing structure for reciprocating motion: 1 - piston rod, 2 - cylinder shell, 2a - bore chamber, 3, 4 - multi-edge pole pieces, 5, 6 - axially polarised permanent magnets, 7 - magnetic fluid, 8 - “Y”-shaped sealing rings, 9 - nut, δ - sealing gap, Φ_1 , Φ_2 - closed magnetic circuits

pieces 3, 4, permanent magnets 5, 6, magnetic fluid 7 and piston rod 1. Through the combined use of the magnetic fluid and the Y-shaped sealing rings, a sealing structure that gives excellent pressure resisting and high sealing performance is formed. Accordingly, due to the fact that the magnetic fluid seal has a dustproof function, the pollution from outside impurities to the Y-shaped sealing rings is reduced, the purity of the sealed medium is improved, and the service interval of the sealing ring is prolonged to the maximum degree, thus meeting the requirements for zero leakage and long service life of hydraulic cylinders.

Fig. 11 shows the reciprocating shaft's sealing apparatus, which combines a ferrofluid seal with hydraulic sealing rings [15]. The sealing device comprises the cylinder shell 2, piston rod 1, axially polarised annular permanent magnet 3, multi-edge pole pieces 4, magnetic fluid 5, two fixed bases 6, Y-seal rings 7 and double acting seal rings 8. The pole pieces 4 separated by permanent magnet 3 are mounted in an inner cavity of the cylinder shell 2. The fixed bases 6, with Y-seal rings 7 and double acting seal rings 8 installed in their grooves, are placed on both ends of the sealing chamber.

These parts are pressed tightly by the end cover 12 connected with the cylinder shell 2 by bolts. The magnetic fluid 5 is injected into the sealing gaps δ before assembling. The closed magnetic circuit Φ is created by permanent magnet 3, multi-edge pole pieces 4, magnetic fluid 5 and piston rod 1. The sealing apparatus, being the combination of a magnetic fluid seal and traditional hydraulic sealing rings, solves the problem of leakage in the reciprocating type of compressors.

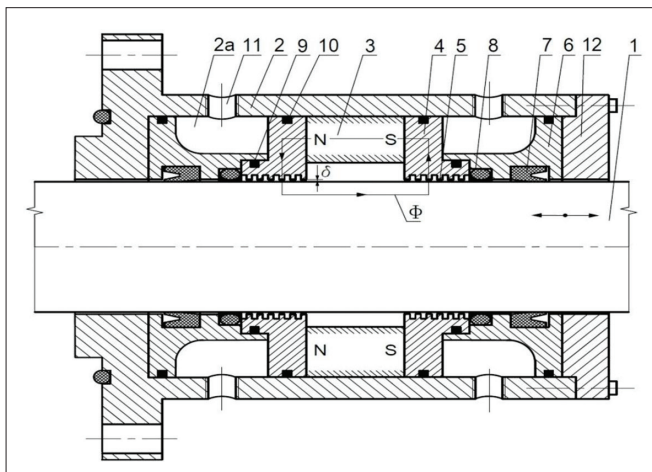

Fig. 11. Reciprocating shafts sealing apparatus combining magnetic fluid seal with double seal-ring and Y-seal-ring: 1 - piston rod, 2 - cylinder shell, 2a - cooling chamber, 3 - axially polarised annular permanent magnet, 4 - multi-edge pole piece, 5 - magnetic fluid, 6 - fixed base, 7 - Y-shaped seal-ring, 8 - double acting seal ring, 9, 10 - "O"-ring seals, 11 - water intake, 12 - cover, δ - sealing gap, Φ - closed magnetic circuit

Fig. 12 shows a combined design seal of the double-acting piston in the hydraulic cylinder with magnetic fluid seals [16]. The sealing set consists of two "U"-shaped sealing rings 4 with back-up rings 5, two axially polarised permanent magnets 6, two non-magnetically permeable sleeves 9, fixed in piston 3 and two multi-edge pole pieces 8 located on each side of piston 3. Two closed magnetic circuits Φ_1 , Φ_2 are created by piston 3, permanent magnets 6, multi-edge pole pieces 8, magnetic

fluid 7 and cylinder shell 2. The magnetic fluid 7 is retained by magnetic forces in small sealing gaps δ between tooth-like projections of piston 3, the multi-edge pole pieces 8 and the inner cylindrical surface of cylinder shell 2, thus providing proper lubrication of the piston and increasing the cylinder tightness.

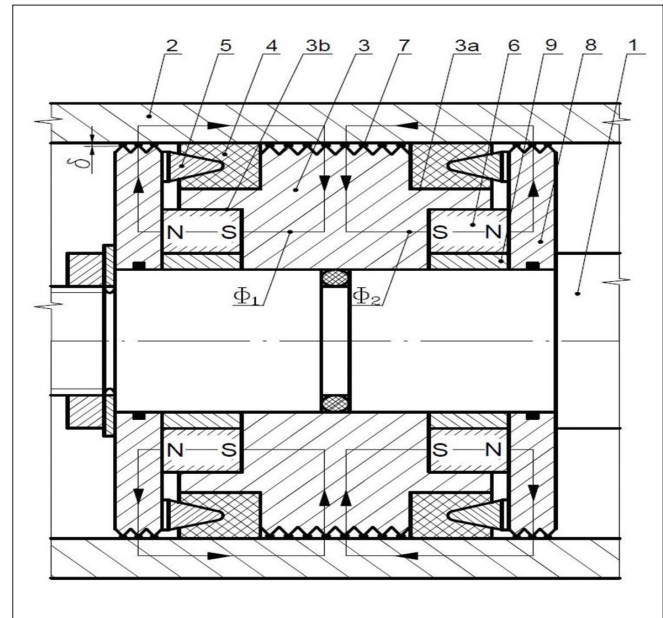

Fig. 12. Combined seal of the double-acting piston in hydraulic cylinder: 1 - piston rod, 2 - cylinder shell, 3 - piston, 3a, 3b - recesses, 4 - "U"-shaped sealing ring, 5 - back-up ring, 6 - axially polarised permanent magnet, 7 - magnetic fluid, 8 - multi-edge pole piece, 9 - non-magnetically permeable sleeve, δ - sealing gap, Φ_1 , Φ_2 - closed magnetic circuits

Fig. 13 presents the variable-tooth and variable-gap type magnetic fluid reciprocating sealing structure for hydraulic cylinders [17]. A number of annular multi-edge pole pieces 6-12 are arranged at intervals in the axial direction in the space between the outer surface of a piston rod 2 and the inner wall of cylinder shell 1. The pole teeth are arranged on the inner circumferential face of each pole piece, while the axial magnetising type permanent magnet 13 is clamped between each pair of the adjacent pole pieces. The polarities of the magnetic poles of each pair of the adjacent axial magnetising type permanent magnets 13 are opposite. The sealing gaps δ created between the pole teeth and the outer surface of piston rod 2 are filled with magnetic fluid 14. The sizes of the sealing gaps δ between the pole teeth and the outer surface of piston rod 2 decrease sequentially in the direction from the high-pressure to the low-pressure side, and the sizes of the sealing gaps δ between all the pole teeth on the same pole piece and the outer surface of piston rod 2 are equal. Closed magnetic circuits Φ are created by pole pieces 6-12, annular permanent magnets 13, magnetic fluid 14 and piston rod 2. According to the principle of operation of the variable-tooth and variable-gap type magnetic fluid reciprocating sealing structure for the hydraulic cylinder, the condition that the pressure endurance capability is gradually enhanced, and the magnetic fluid leakage resistance is gradually increased is obtained through the structure change, and then the effect of further improving the sealing pressure resistance is achieved.

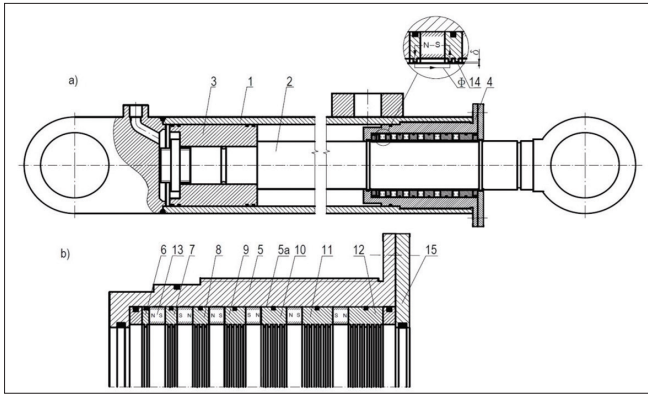

Fig. 13. Variable-tooth and variable-gap type magnetic fluid reciprocating sealing structure for hydraulic cylinder: a) hydraulic cylinder with magnetic fluid sealing structure, b) magnetic fluid sealing structure 1 - cylinder shell, 2 - piston rod, 3 - piston, 4 - head, 5 - flanged bushing, 5a - sealing chamber, 6-12 - multi-edge pole pieces, 13 - axially polarised annular permanent magnet, 14 - magnetic fluid, 15 - cover, δ - sealing gap, Φ - closed magnetic circuit

CONCLUDING REMARKS

The article provides an overview of new seal solutions pointing a ship's main and auxiliary equipment installed on ships. Although the article focuses on the reciprocating movement to point out its characteristic features, in practice this movement is often accompanied with rotating movement. Ship machinery, in general, includes various machines such as the main engine, propulsion engines, electrical generators, etc., various systems such as electrical, piping, refrigeration and air conditioning, firefighting and protection systems, as well as the deck machinery and cargo handling equipment, bow thrusters and stabilisers, instrumentation and control, safety equipment, and other auxiliary machinery and equipment [12, 13, 18]. The auxiliary machinery may operate to support the main propulsion engines, heat exchangers and air compressors, for instance, or to support ship maneuvering and cargo handling – propellers and shafting, steering gear and deck cranes, or to support ship services such as ballast water distribution and sewage systems.

Following shipbuilding area the designers specify the seal types from the point of view of the longest maintenance interval. Service costs in maritime industry are extremely high in comparison with regular factories. Nowadays, ship crews are reduced to a few persons that cannot provide servicing, and the ship operation must rely on the highest durability of machines. Reciprocating shafts can be found in drive and steering systems of critical ship machinery, such as pitch control, various engines including the main one, thrusters, rudder systems, stabilisers, etc. The limited article space here did not allow a detailed presentation of the selected solutions. Moreover, some of them are patent pending. However, the solutions presented in the article provide an opportunity for the readers to decide where and when to use a particular sealing kit.

Although that overview presents general purpose applications of fluid seals the author see their realisation in ship industry particularly sensible. The analysis of the sealing mechanism of magnetic fluid seals in reciprocating motion shows that the operation of these seals is affected by the carry-over phenomenon and magnetic fluid deformation in the

sealing gap, which depends on the speed v of the reciprocating motion. This deformation and the reduction of the amount of magnetic fluid in the sealing gap caused by the reciprocating motion of the piston is the main reason for failures of magnetic fluid seals.

In order to prolong the lifetime of seal operation, newly designed structures are used that prevent the deformation of the magnetic fluid film and reduce the loss of magnetic fluid in the sealing gap. These new structure designs of hybrid seals, being a combination of typical hydraulic seals with magnetic fluid seals for reciprocating motion, have practical application especially in hydraulic cylinders and piston compressors.

REFERENCES

1. Berkovsky B.M., Medvedev V.F., Krakov M.S.: Magnetic Fluids- Engineering Applications, Oxford University Press, Oxford,1993.
2. Magnetic Fluids in Machine Design, Ed. By Orlov D.V.,Podgorkov V.V.,Publisher "Mashinostrojenie", Moscow,1993.
3. Evsin S.I., Sokolov N.A., Stradomsky Y.I,Charkovsky V.B.: Development of magnetic fluid reciprocating motion seals, Journal of Magnetism and Magnetic Materials, vol.85, 1990.
4. Evsin S.I.,Stradomsky Y.I.,Charkovsky V.B.: Classical magnetic liquid seal under conditions of reciprocating motion of a rod, Magneto hydrodynamics, vol. 22,no 3, 1986.
5. Ochoński W.: Magnetic fluid seals for reciprocating motion, Proc. of the 15th Int. Colloquium Tribology, Stuttgart/Ostfildern, January 2006.
6. Patent USA, Int.CL.F16J15/40, no 5165701, Magnetic fluid seal apparatus.
7. Patent PL, Int.CL.F16J15/53, no 187576, Multi-stage magnetic fluid shaft seal (in polish).
8. Patent application P-435694, Hybrid seal for large-size elements with rotating or reciprocating motion (in polish).
9. Patent application P-438268, Hybrid seal for large-size elements with reciprocating motion and rotating motion (in polish).
10. Patent application P-437268, Hybrid seal for elements with reciprocating motion or rotating motion (in polish).
11. Patent PL,Int.CL.F16J15/53, no 234946, Hybrid seal for large-size elements with rotating or reciprocating motion (in polish).

12. Patent CN, Int.CL. F16J15/43, no 109505985, Reciprocating sealing device for hydraulic cylinder magnetic fluid.
13. Patent CN, In.CL. F16J15/43, no 108869751, Combined type magnetofluid reciprocating sealing structure.
14. Patent CN, Int.CL. F16J15/43, no 107893854, Magnetic fluid sealing structure for reciprocating motion.
15. Patent application USA, Int.CL. F16J15/43, no 2011/0215533, Reciprocating shafts sealing apparatus combined a ferrofluid seal with a C-slip-ring and a YX-seal-ring.
16. Patent SU, Int.CL. F16J15/40, no 1537940, Hydraulic cylinder piston packing.
17. Patent CN, Int.CL. F16J15/43, no 108775304, Variable-tooth and variable-gap type magnetic fluid reciprocating sealing structure for hydraulic cylinder.
18. The Maritime Engineering Reference Book – A Guide to Ship Design, Construction and Operation, 2008, Pages 344, 346-482, Chapter 6 – Marine engines and auxiliary machinery. doi: <https://doi.org/10.1016/B978-0-7506-8987-8.00006-8>.

CONTACT WITH THE AUTHORS

Leszek Matuszewski
e-mail: leszekma@pg.edu.pl

Piotr Bela
e-mail: piotr.bela@pg.edu.pl

Gdańsk University of Technology
Narutowicza 11/12
80-233 Gdańsk
POLAND