

SPECTRAL RESPONSE OF STATIONARY JACK-UP PLATFORMS LOADED BY SEA WAVES AND WIND USING PERTURBATION METHOD

Bogdan Rozmarynowski¹

Wojciech Jesien²

¹ Gdańsk University of Technology, Poland

² Pratt & Whitney, Canada

* Corresponding author: bogrozma@pg.edu.pl (B. Rozmarynowski)

ABSTRACT

The paper addresses non-linear vibrations of offshore jack-up drilling platforms loaded by sea waves and wind in their stationary condition using the perturbation method. Non-linearity of dynamic equations of motion for fixed offshore platforms yields from two factors. The first is load excitation generating non-linear velocity coupling in a dynamic system. This coupling is inherent in the modified Morison equation, involving the excitation function in the form of the sum of the inertial and velocity forces of sea waves, taking into account relative wave-structure kinematics. Moreover, the wind acting on the exciting side causes similar effects. The second source is the subsoil-structure interaction problem, modelled by a system of springs and dashpots that yields stochastic non-linearity of the dynamic system. The matrix equations of structural motion in FEM terms are set up. The perturbation method is adopted to determine the mechanical response of the system, making it possible to determine response spectra of the first and the second approximations for displacements and internal forces of the platform. The paper is the continuation of research detailed in the paper [1]. It is assumed, that the fluctuation parts of the dynamic loading forces are in line with the direction of sea wave propagation. Sea current and lift forces effects are neglected in this study. A numerical example refers to structural data of the Baltic drilling platform in the stationary configuration, i.e. when three legs support the deck above the seawater level.

Keywords: Structural dynamics, Offshore structures, Loads, Fluid flexible structure interactions, Random variables, Stochastic processes, Spectral analysis, Perturbation method

INTRODUCTION

Complex conditions of the marine environment and the necessity of installing structures in increasingly deeper regions of the seas and oceans led to the spectacular development of various structural systems of offshore platforms. This development was linked with technological advances in ocean engineering, generated by the development of the oil industry, which triggered intensive development for new drilling sites, especially after the world oil crisis in 1970.

Depending on the application, different types of platforms can be built: for exploration, mining, or auxiliary platforms [2]. Taking into account the main factors that determine the

type of the installed platform, e.g. sea depth, subsoil type, seismic conditions, operation in the Arctic, the following types may be constructed: heavy reinforced concrete platforms, steel jackets, steel jack-up rigs, semi-submersible and spar structures or platforms moored through tethers (i.e. TLP - Tension Leg Platforms). Regardless of the platform type, computational analysis of platforms, necessary in their design [3], involves complex problems regarding the interaction of three media: water, structure, and subsoil. In each offshore platform case, the most important task is to determine wave and wind loads. With regard to environmental conditions, the loads produced by ship collision, ice floe pressure, sea current, and seismic activities should be estimated too [4].

The platforms fixed in the seabed involve a particular task to determine the subsoil parameters and adopt an appropriate failure model for fatigue analysis of structural joints [5]. All the issues described above affect the structural response, which is obtained in an approximated form due to the simplifying assumptions of physical phenomena. And, numerical methods make it possible to obtain approximate solutions for such formulated mathematical problems [6], [7], [8], [9], [10].

The work emphasises the use of the perturbation method to find a solution of non-linear dynamic equations of motion. The origins of the perturbation method or the small parameter method, are included in the works of Poincaré in the nineteenth century (see [11]). The perturbation method was first applied to deterministic systems [12] and later in the analysis of non-linear stochastic systems (see [13], [14], [15]).

The perturbation method is an asymptotic method whose solutions are power series. Convergence of this kind of expansion is usually slow, and in some cases the solution is divergent (see [16]). There are cases when an approximate solution limited to selected terms of the series is sufficient (see [13]). The perturbation method applied to the vibrations of a simplified platform model is addressed by Taylor [17], where the non-linearity of the system refers to damping, fluctuation effects in the modified Morison wave excitation formula. This paper does not cover the stochastic non-linearity caused by subsoil-structure interaction.

This study is the continuation of research presented in the paper [1], and it covers a dynamic analysis of a jack-up, movable type drilling platform (Fig. 1). The novel elements address the wind impact on the platform response. The work presents also a detailed formalism of the perturbation approach to the solution of non-linear platform dynamic systems.

The stationary work condition of a jack-up platform requires it to be attached to the seabed. The soil subsystem interacts with the structure through the foundation, therefore a subsoil-structure interaction problem is essential here, introducing non-linearity to the dynamic system. The study refers to the perturbation approach to the analysis of stochastically non-linear systems.

A simplified subsoil-structure interaction model is assumed as a system of springs and dashpots, representing the elastic and damping properties of the subsoil.

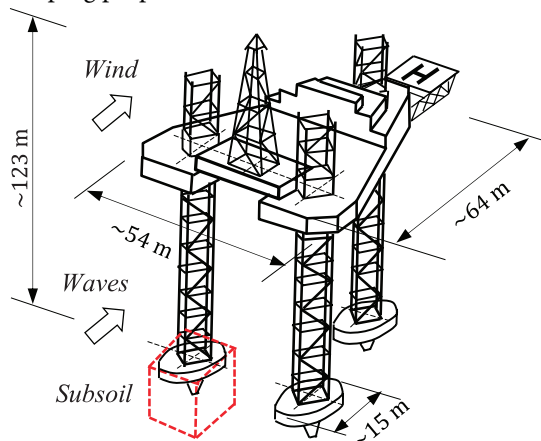

Fig. 1. General view of the platform

In the case of slender, elastic cylindrical members subjected to sea waves, the wave-structure interaction problem is inherently non-linear (see [18]). Waves produce kinematic variations of elastic members coupled with dynamic loads. The following relations hold: $H/D > 1$, $D/L < 0.2$, where H is the wave height, L is the wave length, and D is the cylinder diameter (potential theory is applied, with no diffractions effects).

The results of the proposed dynamic analysis contain the spectral densities of displacements and support reactions. Second-order response spectra are discussed. Detailed analysis of a damping part of the wave forces is provided. A numerical example of the jack-up platform shown in Fig. 1, formulated in real engineering categories, is presented. Numerical calculations were carried out with the help of the FEMAP software system version 10.1.1, the Excel environment, and the authors' computer programs written in Fortran.

DYNAMIC EQUATIONS OF MOTION

In the adopted analysis, it is possible to neglect or include the probabilistic parameters of the structure and its environment. Inertia, damping, and stiffness matrices may take a deterministic or probabilistic form. In such a system, the uncertainty of matrix terms generates excitation forces and subsoil layers. Dynamic equations of motion take a general form:

$$\begin{aligned} \mathbf{M}(\gamma)\ddot{\mathbf{q}}(\gamma, t) + \mathbf{C}(\gamma)\dot{\mathbf{q}}(\gamma, t) + \mathbf{K}(\gamma)\mathbf{q}(\gamma, t) = \\ = \mathbf{P}(t, \dot{\mathbf{q}}(\gamma, t), \ddot{\mathbf{q}}(\gamma, t)) \end{aligned} \quad (1)$$

where γ is an element from a set of elementary events Γ^1 . $\mathbf{M}(\gamma)$ represents the global inertia matrix, involving the structural mass and the mass of surrounding water (the latter called hydrodynamic, associated or added mass); $\mathbf{C}(\gamma)$ is the global damping matrix (deterministic or random) composed of three elastic continuous media: the structure, subsoil, and water; $\mathbf{K}(\gamma)$ is the global stiffness matrix involving subsoil and structural stiffness; $\mathbf{P}(t, \dot{\mathbf{q}}(\gamma, t), \ddot{\mathbf{q}}(\gamma, t))$ is the global vector of forces produced by sea waves and the wind acting on the platform. The latter time-variant vector with structural velocity vector $\dot{\mathbf{q}}(\gamma, t)$ and acceleration vector $\ddot{\mathbf{q}}(\gamma, t)$ affect the dynamic performance of the platform. Kinematic wave-structure coupling makes Eq. (1) non-linear. The orders of the listed matrices and vector are $n \times n$ and $n \times 1$, respectively, where n is the number of dynamic degrees of freedom.

While the equation coefficients and excitation function are uncertain, the dynamic system expressed by Eq. (1) is called stochastically non-linear (see [19], [20]).

It was found that a dynamic structure-subsoil-water system (Eq. (1)) involves a relation between the matrices $\mathbf{M}, \mathbf{C}, \mathbf{K}$ and the vibration frequency due to the hydrodynamic mass, damping and stiffness caused by the subsoil (see [21]). This relationship makes Eq. (1) more complex.

¹ This set contributes the component of probability space $(\Gamma, \mathcal{F}, \mathcal{P})$, where \mathcal{F} is a σ -algebra of subsets of Γ , \mathcal{P} is a probability measure defined on \mathcal{F} [16].

MASS MATRIX

The mass of the oscillating platform is concentrated at nodes of its discrete FEM model, thus the kinetic energy of the system involves translational degrees of freedom only. This simplification meets the expected accuracy of numerical computations, where the rotational inertia is negligible (e.g., the Timoshenko model in the structural dynamics of bars [22]).

The platform masses and the subsoil parameters are assumed independent of frequency. The mass of the added water is affected by the submerged element shape (see [5], [9], [10]). The work [21] indicates a relation between the added masses and the wave frequency. Due to small variations, it is routine in numerical computations of platform response that the added masses are constant throughout the wave excitation frequency range.

The total mass of the dynamic system follows the summation:

$$\mathbf{M} = \mathbf{M}_P + \mathbf{M}_S + \mathbf{M}_H, \quad (2)$$

where matrices \mathbf{M}_P , \mathbf{M}_S , \mathbf{M}_H are the global mass matrix of the structure, subsoil, and associated (hydrodynamic) water, respectively.

The terms of the matrix \mathbf{M}_S are based on [23]. Taking into account the additional subsoil mass matrix \mathbf{M}_s , the lumped soil is considered in the form of a cube (see Fig. 1), and its empirical coefficient depends on the oscillating mass (Table 1).

Table 1. Coefficients of co-oscillating subsoil masses

Degree of freedom of added mass	Added mass
Vertical	$1.50\rho_s R^3$
Horizontal	$0.28\rho_s R^3$
Rotational	$0.49\rho_s R^5$
Torsional	$0.70\rho_s R^5$

In Table 1 ρ_s is the soil density, R is the radius of the rigid disc resting on the subsoil (see Fig. 1).

The elements of the matrix \mathbf{M}_H are derived from the modified form of the Morison formula (see [1], [6], [21]). It should be emphasised that non-zero hydrodynamic masses occur only at nodes corresponding to structural elements immersed in water.

DAMPING MATRIX

The global damping matrix \mathbf{C} is the superposition of three matrices:

$$\mathbf{C} = \mathbf{C}_P + \mathbf{C}_S + \mathbf{C}_H \quad (3)$$

where the P , S , and H indices refer to structural damping, subsoil, and co-oscillating (hydrodynamic) water damping, respectively.

Structural damping, i.e., material damping produced by internal friction in the element material and damping in the joints between the structural elements, is approximated by the equivalent viscous damping according to the formula $\mathbf{C}_P = \alpha_M \mathbf{M}_P + \alpha_K \mathbf{K}_P$ (see [24]), and the coefficients α_M , α_K are defined by the so-called proportional damping (Rayleigh damping) of a “dry” structure. i.e., without a subsoil and surrounding water impact (see e.g. [23]).

Thus, the \mathbf{C}_P matrix is a linear combination of a kinetic energy measure (mass matrix) representing external damping and a potential energy measure (stiffness matrix) expressing the internal damping of a dynamic system.

Subsoil damping (the matrix \mathbf{C}_S in Eq. (3)) is reflected by a system of dashpots of frequency-variant parameters. These parameters are discussed in [1], [6], where the subsoil model is an elastic half-space. A weightless plate rests on an elastic subsoil and it is subjected to harmonic excitation. This pattern refers to radiation-type damping. The hysteretic (internal) damping of the subsoil is associated with its viscoelastic model (see [25]).

The damping part related to hydrodynamic damping \mathbf{C}_H occurs only in the nodes immersed in water. This issue is addressed in detail in [7], where the stochastic averaging method is used to solve non-linear platform vibrations.

STIFFNESS MATRIX

The system stiffness covers the structural stiffness (3D beam finite elements) and stiffness of the subsoil, represented by six springs along the DOFs (degrees of freedom) of the support nodes of the discrete platform model.

We assume the following superposition of the global stiffness matrix:

$$\mathbf{K} = \mathbf{K}_P + \mathbf{K}_S \quad (4)$$

where \mathbf{K}_P represents the global stiffness matrix of a platform made of 3D beam elements, and \mathbf{K}_S is a matrix representing contact between the platform structure and the subsoil.

While the structure–subsoil contact is modelled by a system of six springs and dashpots, the matrices \mathbf{K}_S and \mathbf{C}_S include six diagonal elements, referring to three translations and three rotations. In the probabilistic terms, the soil shear modulus G is represented by a Gaussian random variable, while Poisson’s ratio ν and mass density ρ_s are assumed to be deterministic. The mean values and variances of the stiffness and damping parameters are presented in [1], [6].

EXCITATION FORCES

The right-hand side of the equation of motion (1) specifies the marine environment of the offshore structures. Excitation forces are affected by the environment, i.e., waves, wind, and subsoil deformations (e.g., support settlement, seismic interactions, etc.).

The force vector in Eq. (1) includes components derived from a field of sea waves and wind. The random event identifier γ

is neglected here.

Let the total force vector be:

$$\mathbf{P}(t, \dot{\mathbf{q}}(t), \ddot{\mathbf{q}}(t)) = \mathbf{P}_F(t, \dot{\mathbf{q}}(t), \ddot{\mathbf{q}}(t)) + \mathbf{P}_W(t, \dot{\mathbf{q}}(t)) \quad (5)$$

where \mathbf{P}_F is a sea wave load vector at structural nodes in the immersed part, \mathbf{P}_W is a wind load vector at nodes above sea level.

The vectors \mathbf{P}_F and \mathbf{P}_W are time functions, with the structural velocity vector $\dot{\mathbf{q}}$ and the acceleration vector $\ddot{\mathbf{q}}$ (see Eq. (A.1) in Appendix).

In the probabilistic approach, the vectors \mathbf{P}_F and \mathbf{P}_W are the functions of random parameters, i.e., wave height, wave period, hydrodynamic coefficients, wind speed, sea current velocity, biological growth of elements immersed in seawater, etc. In papers [1], [6], it was assumed that wave and wind loads given a linear form are considered Gaussian, ergodic, stationary, and independent processes with zero means. Thus the linear sum of the processes expressed in formula (5) is also a stationary and ergodic Gaussian process.

SUBSOIL-STRUCTURE INTERACTION PROBLEM

The components of the dynamic equation of motion (1), based on the structure-subsoil interaction problem, are defined by the mass, damping, and stiffness matrices, i.e., \mathbf{M}_s , \mathbf{C}_s and \mathbf{K}_s (see Eqs. (2), (3), (4), and Table 1, respectively).

Three models are possible to analyse the structure-subsoil co-oscillating system:

1. Deterministic model 1 - constant parameters of stiffness and subsoil damping. This simplifying approach leads to a system of differential equations with constant coefficients. It is a numerical problem to apply equations uncoupled by modal reduction, while soil damping is high compared to structural damping, so the Rayleigh proportional damping may be irrelevant. In numerical terms, the modal transformation makes the mass and structural damping matrices diagonal, but the subsoil damping matrix does not follow; hence the equations are coupled. The work [23] shows that the subsoil damping matrix may be diagonalised if the least-squares method is applied to minimise the error function. This work assumes that the motion components associated with the rigid body structural vibrations are uncoupled.
2. Deterministic model 2 - variable parameters of stiffness and subsoil damping, the latter frequency variant. A system of differential equations with variable coefficients is solved. Relevant approximation functions are applied to the variable equation parameters (see [25]).
3. Random model - here the stiffness and subsoil damping parameters are random variables. The stiffness coefficients are Gaussian random variables while they

are with Gaussian distributed soil shear modulus G . Poisson's ratio and the mass density are deterministic. The damping factors are non-linear with regard to the shear modulus, so the mean values and variances of these parameters are achieved by an approximate solution - Taylor's series expansion. The mean values and variances of the subsoil stiffness and damping coefficients are presented in [1] and [6].

Deterministic models allow one to solve the contact problem in the time or frequency domains [19]. If the second deterministic model is applied, it is convenient to perform the analysis in a frequency domain. The stiffness terms associated with structural degrees of freedom decrease with increasing frequency, more for translational than rotational DOFs [23]. In the case of random models the solution may involve approximation methods, e.g., spectral analysis, a perturbation approach, averaging and simulation methods, etc.

PERTURBATION SOLUTION APPROACH

The dynamic equations of motion of the platform belong to a non-linear class of equations in both deterministic and probabilistic terms. The origin of non-linearity is the velocity component of force summation in a dynamic system and the coefficients of substitute springs and dashpots modelling the subsoil-structure interaction. These coefficients are frequency-variant, affected by the random subsoil shear modulus [6].

Different methods can be used to solve Eq. (1) (see [1], [7], [17]). In this study, the perturbation method is used.

The perturbation method is an asymptotic method, whose solutions are power series. Limiting an approximate solution to selected terms of a series makes a sufficient approximation in a variety of problems (see [11], [13]).

The fluctuations of random coefficients of the matrix in Eq. (1) are assumed to be small, and the perturbations of random magnitudes are limited to the first- or second-order approximations of the response series expansion (see [17]). The reference work regards the interaction of non-linear damping wave forces with a structural response, but neglects the soil-structure interaction problem.

Thus the matrix coefficients of Eq. (1) defined by the inertia, damping, and stiffness matrices are random variables as follows:

$$\begin{aligned} \mathbf{M} &= \mathbf{M}_0 + \varepsilon \mathbf{M}_1(\gamma), \\ \mathbf{C} &= \mathbf{C}_0 + \varepsilon \mathbf{C}_1(\gamma), \\ \mathbf{K} &= \mathbf{K}_0 + \varepsilon \mathbf{K}_1(\gamma) \end{aligned} \quad (6)$$

where index "0" is the mean coefficient, index "1" represents fluctuation, γ is an elementary event of an elementary space Γ , and ε is the small parameter, $\varepsilon \ll 1$.

The solution of Eq. (1) takes the perturbation expansion form:

$$\mathbf{q}(\gamma, t) = \mathbf{q}_0(\gamma, t) + \varepsilon \mathbf{q}_1(\gamma, t) + \varepsilon^2 \mathbf{q}_2(\gamma, t) + \dots \quad (7)$$

where terms up to ε^2 are retained, since the variable linear parts associated with the small parameter ε are not correlated with the excitation forces.

The operator of Eq. (1), $\mathbf{L} = \mathbf{L}(\gamma, t, \varepsilon)$, triggers:

$$\mathbf{L}\mathbf{q} = \mathbf{P}, \quad (8)$$

where $\mathbf{L} = \mathbf{L}(\gamma) = \mathbf{L}_0 + \varepsilon \mathbf{L}_1(\gamma) + \dots$, $\mathbf{q}(\gamma, t)$ s defined by Eq. (7), $\mathbf{P} = \mathbf{P}(\gamma, t) = \mathbf{P}_0(\gamma, t) + \varepsilon \mathbf{P}_1(\gamma, t) + \dots$ (see the Appendix and the load vector \mathbf{P}).

Expanding Eqs. (6) and (7) and comparing the corresponding terms, the set of equations takes the form:

$$\begin{aligned} \mathbf{L}_0 \mathbf{q}_0 &= \mathbf{Z}_0 \\ \mathbf{L}_0 \mathbf{q}_1 &= \mathbf{Z}_1 \\ \mathbf{L}_0 \mathbf{q}_2 &= \mathbf{Z}_2 \\ &\dots \end{aligned} \quad (9)$$

where .

$$\begin{aligned} \mathbf{L}_0 \mathbf{q}_0 &= \mathbf{M}_0 \ddot{\mathbf{q}}_0 + \mathbf{C}_0 \dot{\mathbf{q}}_0 + \mathbf{K}_0 \mathbf{q}_0, \\ \mathbf{Z}_0 &= \mathbf{P}_0, \mathbf{Z}_1 = \mathbf{P}_1 - \mathbf{L}_1 \mathbf{q}_0, \\ \mathbf{L}_1 \mathbf{q}_0 &= \mathbf{M}_1(\gamma) \ddot{\mathbf{q}}_0 + \mathbf{C}_1(\gamma) \dot{\mathbf{q}}_0 + \mathbf{K}_1(\gamma) \mathbf{q}_0, \\ \mathbf{Z}_2 &= -\mathbf{L}_1 \mathbf{q}_1 = -[\mathbf{M}_1(\gamma) \ddot{\mathbf{q}}_1 + \mathbf{C}_1(\gamma) \dot{\mathbf{q}}_1 + \mathbf{K}_1(\gamma) \mathbf{q}_1]. \end{aligned}$$

Formula (9) is a hierarchical set of linear equations of static equilibrium with deterministic coefficients and random excitations: \mathbf{Z}_0 , \mathbf{Z}_1 and \mathbf{Z}_2 . Regarding a vector \mathbf{Z}_1 , its approximation $\mathbf{Z}_1 \approx -\mathbf{L}_1 \mathbf{q}_0$ follows the linearisation method of Malhotra and Penzien [27] applied to the drag term of wave forces. Note that the excitation of the second equation is caused by the solution of the first equation, etc.

RESPONSE SPECTRA

The first Eq. (9) covers the stochastically linear problem in terms of the spectral density function $\mathbf{S}_{q_0q_0}(\omega)$, while the second and third equations are related to higher-order spectra. Regarding the order ε^2 , the response spectral density is:

$$\begin{aligned} \mathbf{S}_{qq}(\omega) &= \mathbf{S}_{q_0q_0}(\omega) + \varepsilon [\mathbf{S}_{q_0q_1}(\omega) + \mathbf{S}_{q_1q_0}(\omega)] \\ &+ \varepsilon^2 [\mathbf{S}_{q_1q_1}(\omega) + \mathbf{S}_{q_0q_2}(\omega) + \mathbf{S}_{q_2q_0}(\omega)] \end{aligned} \quad (10)$$

where the indices q_r, q_s , ($r, s = 0, 1, 2$) refer to the displacement components defined by Eq. (7).

The spectral density matrices in Eq. (10) associated with the small parameter ε equal zero (the autocorrelation function between vectors \mathbf{q}_0 and \mathbf{q}_1 is $\mathbf{R}_{q_0q_1}(\tau) = 0$, thus $\mathbf{S}_{q_0q_1}(\omega) = 0$). Two issues are vital here: zero-mean stochastic processes of the excitation process and cumulants of an order higher than two may be neglected for Gaussian approximation [17].

The following remarks are highlighted in the inquiry above:

1. Random variables $\mathbf{M}_1(\gamma)$, $\mathbf{C}_1(\gamma)$, $\mathbf{K}_1(\gamma)$ are small-valued and independent of $\mathbf{q}_0(\gamma, t)$. Thus the vector process \mathbf{Z}_1 is stationary in a broad sense and ergodic

in autocorrelation;

2. Fluctuating components of the matrices in Eq. (6) are defined by diagonal matrices:

$$\begin{aligned} \mathbf{M}_1(\gamma) &= \text{diag}[M_{S_i}(\gamma)], \mathbf{C}_1(\gamma) = \\ &\text{diag}[C_{S_i}(\gamma)], \mathbf{K}_1(\gamma) = \\ &\text{diag}[K_{S_i}(\gamma)] \end{aligned} \quad (11)$$

where $M_{S_i}(\gamma)$ is defined by soil masses (according to Table 1 including the mean values), while $C_{S_i}(\gamma)$ and $K_{S_i}(\gamma)$ are the random damping and stiffness of the soil addressed by Jesien [6] and [1];

3. The full correlation holds between the fluctuation components listed above;
4. Spectral density matrices $\mathbf{S}_{q_0q_1}(\omega) = \mathbf{S}_{q_1q_0}(\omega)$, $i = 1, 2$ show all zero terms (see [17]).

The presented argument leads to:

$$\mathbf{Z}_1 \approx -\mathbf{L}_1 \mathbf{q}_0 = [\mathbf{Z}_M + \mathbf{Z}_C + \mathbf{Z}_K] \quad (12)$$

where

$$\begin{aligned} \mathbf{Z}_M &= \mathbf{Z}_M(\gamma, t) = \mathbf{M}_1(\gamma, t) \ddot{\mathbf{q}}_0(\gamma, t), \\ \mathbf{Z}_C &= \mathbf{Z}_C(\gamma, t) = \mathbf{C}_1(\gamma, t) \dot{\mathbf{q}}_0(\gamma, t), \text{ and} \\ \mathbf{Z}_K &= \mathbf{Z}_K(\gamma, t) = \mathbf{K}_1(\gamma, t) \mathbf{q}_0(\gamma, t). \end{aligned}$$

The spectral density matrix of \mathbf{Z}_1 is:

$$\begin{aligned} \mathbf{S}_{Z_1Z_1}(\omega) &= \mathbf{S}_{Z_MZ_M}(\omega) + \mathbf{S}_{Z_MZ_C}(\omega) + \mathbf{S}_{Z_MZ_K}(\omega) + \\ &\mathbf{S}_{Z_CZ_M}(\omega) + \mathbf{S}_{Z_CZ_C}(\omega) + \mathbf{S}_{Z_CZ_K}(\omega) + \\ &\mathbf{S}_{Z_KZ_M}(\omega) + \mathbf{S}_{Z_KZ_C}(\omega) + \mathbf{S}_{Z_KZ_K}(\omega) \end{aligned} \quad (13)$$

where:

$$\begin{aligned} \mathbf{S}_{Z_MZ_M}(\omega) &= \omega^4 \boldsymbol{\sigma}_M \mathbf{S}_{q_0q_0}(\omega) \boldsymbol{\sigma}_M, \mathbf{S}_{Z_MZ_C}(\omega) = i\omega^3 \boldsymbol{\sigma}_M \mathbf{S}_{q_0q_0}(\omega) \boldsymbol{\sigma}_C, \\ \mathbf{S}_{Z_MZ_K}(\omega) &= -\omega^2 \boldsymbol{\sigma}_M \mathbf{S}_{q_0q_0}(\omega) \boldsymbol{\sigma}_K, \mathbf{S}_{Z_CZ_M}(\omega) = -i\omega^3 \boldsymbol{\sigma}_C \mathbf{S}_{q_0q_0}(\omega) \boldsymbol{\sigma}_M, \\ \mathbf{S}_{Z_CZ_C}(\omega) &= -\omega^2 \boldsymbol{\sigma}_C \mathbf{S}_{q_0q_0}(\omega) \boldsymbol{\sigma}_C, \mathbf{S}_{Z_CZ_K}(\omega) = i\omega \boldsymbol{\sigma}_C \mathbf{S}_{q_0q_0}(\omega) \boldsymbol{\sigma}_K, \\ \mathbf{S}_{Z_KZ_M}(\omega) &= -\omega^2 \boldsymbol{\sigma}_K \mathbf{S}_{q_0q_0}(\omega) \boldsymbol{\sigma}_M, \mathbf{S}_{Z_KZ_C}(\omega) = -i\omega \boldsymbol{\sigma}_K \mathbf{S}_{q_0q_0}(\omega) \boldsymbol{\sigma}_C, \\ \mathbf{S}_{Z_KZ_K}(\omega) &= \boldsymbol{\sigma}_K \mathbf{S}_{q_0q_0}(\omega) \boldsymbol{\sigma}_K \end{aligned}$$

and $\boldsymbol{\sigma}_M = \text{diag}(\sigma_{M_{ii}})$, $\boldsymbol{\sigma}_C = \text{diag}(\sigma_{C_{ii}})$, $\boldsymbol{\sigma}_K = \text{diag}(\sigma_{K_{ii}})$ are diagonal matrices, whose elements show standard deviations by Eq. (13).

The spectral density matrices of $q_0(\gamma, t)$ and $q_1(\gamma, t)$ take the form:

$$\mathbf{S}_{q_r q_r}(\omega) = \mathbf{H}_{q_r Z_r}(\omega) \mathbf{S}_{Z_r Z_r}(\omega) \mathbf{H}_{Z_r q_r}^*(\omega) \quad (14)$$

where $\mathbf{H}_{q_r Z_r}(\omega) = (\mathbf{K}_0 - \omega^2 \mathbf{M}_0 + i\omega \mathbf{C}_0)^{-1}$ is the complex transfer function matrix (see [1]), and $\mathbf{H}_{Z_r q_r}^*$ is its complex conjugate transpose, $r = 0, 1$.

Similarly to Eq. (14), the spectral density matrix in the reduced modal space $\mathbf{q} = \boldsymbol{\Phi}_h \mathbf{y}_h$, where $\boldsymbol{\Phi}_h$ is the matrix of eigenvectors of order $(n \times h)$, $h < n$, has the form:

$$\mathbf{S}_{y_r y_r}(\omega) = \widehat{\mathbf{H}}_{y_r Z_r}(\omega) \widehat{\mathbf{S}}_{Z_r Z_r}(\omega) \widehat{\mathbf{H}}_{Z_r y_r}^*(\omega) \quad (15)$$

where $\hat{H}_{y_r z_r} = [\Phi_h^T (K_0 - \omega^2 M_0 + i\omega C_0) \Phi_h]^{-1}$,
 $\hat{S}_{Z_r Z_r}(\omega) = \Phi_h^T S_{Z_r Z_r} \Phi_h$, $r = 0, 1$,

The spectral density matrix of the displacement vector $q(y, t)$ in Eq. (7) reads:

$$S_{qq}(\omega) = S_{q_0 q_0}(\omega) + \varepsilon^2 S_{q_1 q_1}(\omega) \quad (16)$$

Following Eq. (16), the response spectral density matrix $S_{qq}(\omega)$ is the sum of the two components. The first, i.e., the $S_{q_0 q_0}(\omega)$ matrix, is the first approximation, the second component, $S_{q_1 q_1}$, is the second approximation.

The response spectral density matrix of the internal forces of the j th beam element is:

$$S_{SS}^j(\omega) = K_P^j S_{qq}^j(\omega) (K_P^j)^T \quad (17)$$

where $S_{SS}^j(\omega)$ and $S_{qq}^j(\omega)$ denote the spectral density matrices of the internal forces and displacements for the element j respectively, and K_P^j is the stiffness matrix of the element j .

NUMERICAL EXAMPLE

A discrete 3D beam model of the platform is presented in Fig. 1. The axial, torsional, and bending stiffness parameters of the deck and columns of the platform are based on structural details shown in Fig. 2, 3, and 4.

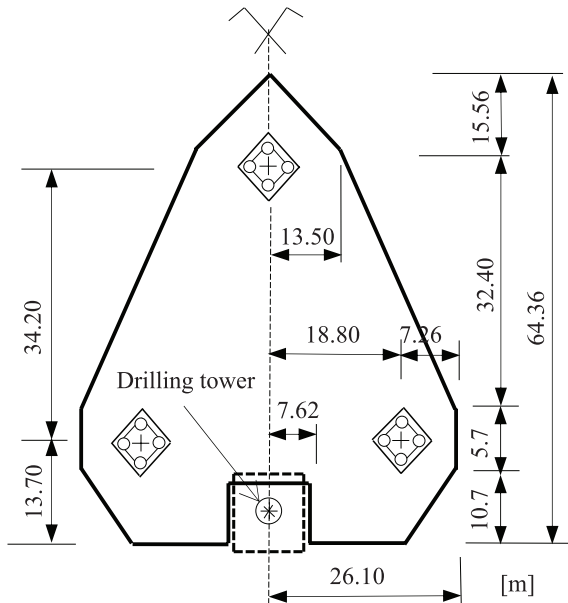

Fig. 2. Platform deck projection

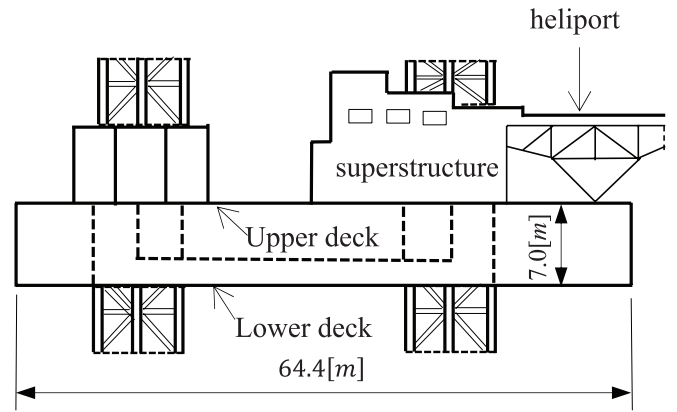

Fig. 3. Longitudinal cross-section of the platform

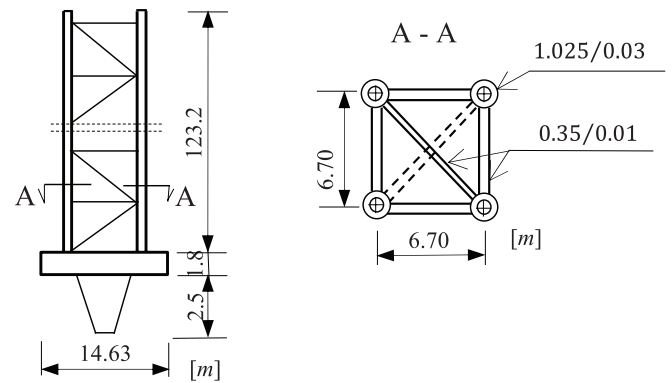

Fig. 4. Cross-sections of the platform leg

3D beam finite elements and the corresponding numbers of nodes are shown in Fig. 5 (see [1], [6]). The model specifies elastic supports and dashpots representing the stiffness and damping of the subsoil, respectively. This model involves 72 degrees of freedom. The axial, bending, and torsional stiffness parameters of the FEM beam model are (see [1]): $EA = \{8.40 \cdot 10^5; 0.79 \cdot 10^5\}$ [MN], $EJ = \{2.53 \cdot 10^6; 8.93 \cdot 10^5\}$ [MNm²], $GJ_s = \{1.94 \cdot 10^6; 6.86 \cdot 10^5\}$ [MNm²], the first part related to the deck, the second part referring to the legs of the structure. The total mass of the structure is $7710 \cdot 10^3$ [kg], regarding the deck and the legs.

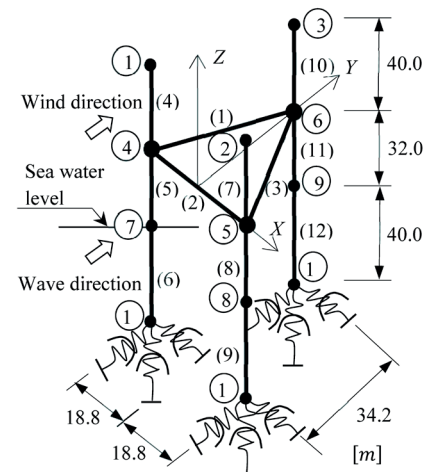

Fig. 5. Space FEM discrete model of the platform

The following data of the subsoil, wind and wave parameters are assumed:

- subsoil parameters: $E = 60[MPa]$, $\nu = 0.4$, $E(G) = 21.4[MPa]$, $\sigma_G = E(G)/2 = 10.7[MPa]$ (Young's modulus, mean value, and standard deviation of the shear modulus, respectively).
- wind parameters: $\bar{v}_{10} = 40[m/s]$, $K = 0.005$, $L = 1200[m]$, $a = b = c = 1$ (mean wind speed 10 m above the surface, surface drag coefficient, the length scale of turbulence, and empirical coefficients in Davenport's formula [28], representing the cross-spectral density of the longitudinal wind fluctuation velocity, respectively).
- wave parameters: $\bar{H} = 14m$, $\bar{T} = 10s$, $\bar{L} = 180m$, $C_M' = C_M'' = C_D = 1$ (mean height, period, and length for long-crested waves, empirical inertia, and drag coefficients of the Morison equation).

Fig. 6 presents the three lowest mode shapes of the free vibration problem.

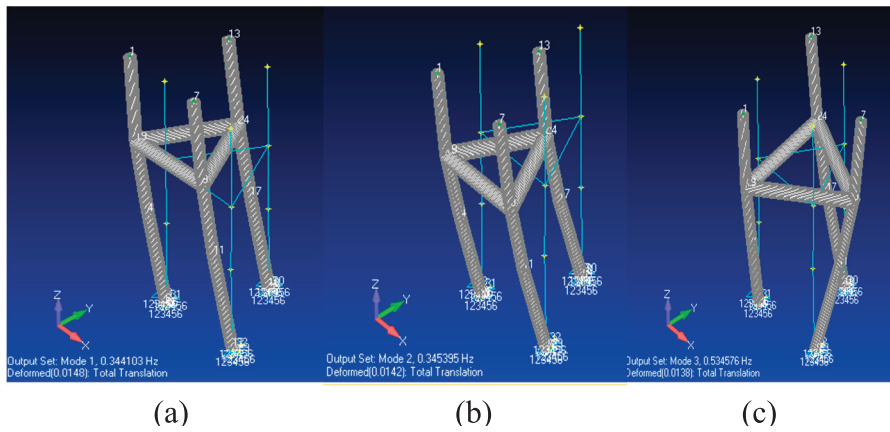

Fig. 6. The first three mode shapes of the platform: (a) $\omega_1 = 2.16 \text{ rad/s}$, (b) $\omega_2 = 2.17 \text{ rad/s}$, (c) $\omega_3 = 3.36 \text{ rad/s}$

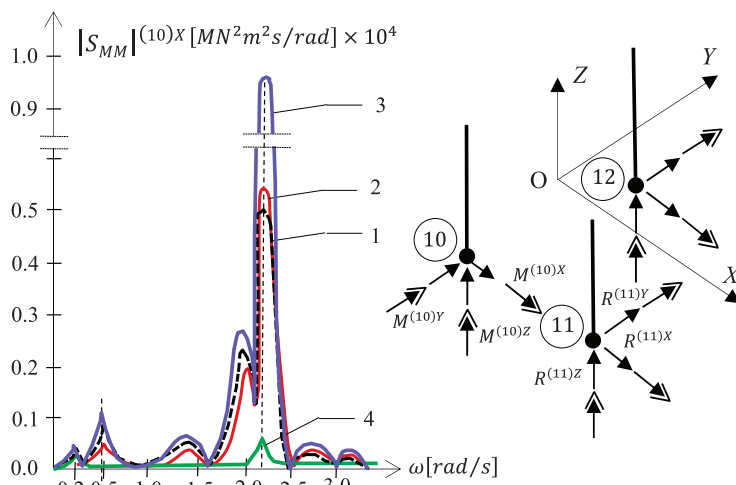

Fig. 7. Spectrum moduli of the responses of the FEM platform model loaded by waves and wind (the bending moment at the node 10 about OX-axis. 1: solution of a linear stochastic problem for waves and wind loads, 2: solution by stochastic averaging method [1], [7] (see waves only), 3: perturbation solution of a non-linear stochastic problem, 4: solution of a stochastic linear problem for wind load only (see [6])

The cross-spectral density functions of the wave and wind loads are presented in [1].

Fig. 7 shows the bending moment power spectrum modules in the spring of the rotating support node (10), taking into account the solution of a linearised stochastic problem for wave and wind loads (curve 1), the stochastic averaging method regarding wave loads only (curve 2), the stochastic non-linear case with uncertain subsoil parameters (curve 3) and the solution regarding wind loads only (curve 4). The results were obtained for modal space reduction with $h = 7$ eigenvectors. In the spectrum waveform, the characteristic values are observable along the frequency axis ω , corresponding adequately to the frequency of the extreme wind spectrum ($\omega = 0.2 \text{ rad/s}$), the frequency of the extreme wave spectrum ($\omega = 0.5 \text{ rad/s}$) and the mean value of the first natural frequency ($\omega = 2.16 \text{ rad/s}$). Numerical integrations of these four response spectra variants lead to the following standard deviations of the bending moment at node 10: $\sigma_M = \{47.3; 44.5; 54.9; 20.9\}[MNm]$.

DISCUSSION

The perturbation method was used to study the non-linear vibration effects of the platform-wave-wind-subsoil interaction system. Two types of non-linear problems occur here. The first type stems from the modified Morison equation for wave loading (wave-structure interaction problem), the second one involves coefficients of the system of dynamic equations of motion containing components in the form of random variables (soil-structure interaction effects) defining the system as stochastically non-linear. The wave-structure interaction problem is included here by the added mass and hydrodynamic damping terms (see Eqs. (A.2) and (A.3)), and the fluctuating damping part of the wave force associated with a small parameter. Neglecting this part and assuming the stochastically linearised wind forces, the response spectra with the second-order terms of the jack-up structure considered in real engineering categories were presented.

1. Based on the numerical computations in this study and other published research, the following observations can be made: The response spectral density functions highlight two important features of structural behaviour. The first is that the variances are statistical parameters of the analysed processes. The second is that the distribution of the response spectra shows the dominant content in the frequency range associated with the structural natural frequencies (resonance zones).

2. A linearised structural response spectrum is a frequency function employing a linearised form of damping forces, which includes deterministic parameters of the subsoil. The introduction of random parameters converts the problem from a stochastically linear to a stochastically non-linear problem (the system equation operator is random).
3. Modal reduction of a dynamic system significantly simplifies the numerical computations, incorporating the lowest vibration forms (the presented example shows a 10% reduction of dynamic degrees of freedom). Due to the significant material damping, the subsoil introduces a disturbance in the modal formulation of the problem.
4. The subsoil-structure interaction effects represent non-linearity in the frequency range close to the first structural natural frequency. In the presented example the peak value of the bending moment spectrum at the first natural frequency is approximately twice the value of its linearised response. Beyond the resonance zones, the differences between linear and non-linear effects are negligible.
5. Zero values in the response spectra are caused by a sign change in the wave load on the platform legs, a problem that was noted and explained by Jesien [6].
6. The mean fluctuation peak of the wind velocity spectrum appears at the response spectrum due to wind load. The values of the peak are amplified at this frequency, but only in the resonance zones. Fig. 7 shows that the impact of the wind load on the response power spectrum is low (6% at the peak value of the resonance zone, as shown in variants 3 and 4).
7. The fluctuating part of the damping wave excitation force (i.e. the term P_{li} of Eq. (A.4) in the Appendix) in the structural response spectral analysis leads to higher-order convolution spectra of wave-particle kinematics (see [7], [17]). These response effects are insignificant for real sea states.
8. In offshore dynamic systems with small element diameters compared to the wave height, the main damping is produced by a wave velocity term of excitation forces. In RC platforms with significant dimensions of the submerged elements and significant mass, wave field disturbance (diffraction) occurs, and significant damping of the dynamic system is generated by the subsoil [5], [9].

CONCLUSION

The dynamic response of jack-up platforms subjected to wind and wave loads is more severe if the higher-order wave load components and uncertainty of subsoil parameters are included, and the problem is treated as a stochastically non-linear dynamic system. The linearisation of the platform dynamic system leads to underestimation of the system's dynamic response.

The inclusion of non-linear effects due to wave-structure and subsoil-structure interactions reveals substantial differences in the peaks of the response spectra in the resonance zone vs. the linearised form of the response spectra (with the non-linear effects being neglected).

These findings deserve future research, including the wave-structure kinematics interaction process.

REFERENCES

1. B. Rozmarynowski, "Spectral dynamic analysis of a stationary jack-up platform," *Polish Marit. Res.*, vol. 26, no. 101, pp. 40–48, 2019, doi: 10.2478/pomr-2019-0005.
2. S. K. Chakrabarti, *Handbook of Offshore Engineering*, vol. I. Elsevier Ltd, 2005.
3. Y. Bai, *Marine Structural Design*. Elsevier Ltd, 2003.
4. S. E. Hirdaris et al., "Loads for use in the design of ships and offshore structures," *Ocean Eng.*, vol. 78, pp. 131–174, 2014, doi: <https://doi.org/10.1016/j.oceaneng.2013.09.012>.
5. N. D. Barltrop and A. J. Adams, *Dynamics of Fixed Marine Structures*, 3rd ed. Butterworth-Heinemann Ltd, 1991.
6. W. Jesien, "Random vibration of the Baltic drilling platform subjected to wind loads and water waves," *Earthq. Eng. Struct. Dyn.*, vol. 15, pp. 595–617, 1987, doi: 0098-8847/87/050595-23.
7. B. Rozmarynowski, "Averaged damping in random vibrations of the Baltic drilling platform," *J. Sound Vib.*, vol. 139, no. 3, pp. 437–458, 1990, doi: [https://doi.org/10.1016/0022-460X\(90\)90675-P](https://doi.org/10.1016/0022-460X(90)90675-P).
8. G. Clauss, E. Lehmann, and C. Østergaard, *Offshore Structures: Conceptual Design and Hydromechanics*, vol. 1. Springer Berlin Heidelberg, 1992.
9. G. Clauss, E. Lehmann, and C. Østergaard, *Offshore Structures Volume II Strength and Safety for Structural Design*. Springer Berlin Heidelberg, 1994.
10. J. F. Wilson, *Dynamics of offshore structures*. John Wiley & Sons, 1988.
11. M. H. Holmes, *Introduction to perturbation methods*. New York: Springer, 2013.
12. A. Nayfeh, *Perturbation methods*. New York: John Wiley & Sons, 1973.
13. S. H. Crandall, "Perturbation techniques for random vibration of non-linear systems," *J. Acoust. Soc. Am.*, vol. 35, pp. 1700–1705, 1963, doi: <https://doi.org/10.1121/1.1918792>.

14. Y. K. Lin, Probabilistic theory of structural dynamics. New York: McGraw Hill, 1967.
15. M. Kaminski, The stochastic perturbation method for computational mechanics. Chichester: John Wiley & Sons, 2013.
16. K. Sobczyk, Stochastic differential equations for applications. Lyngby: Technical University of Denmark, 1985.
17. R. E. Taylor and A. Rajagopalan, "Dynamics of offshore structures, part I: perturbation analysis," J. Sound Vib., vol. 83, no. 3, pp. 401–416, 1982.
18. S. Massel, Ocean surface waves: their physics and prediction. Singapore: World Scientific, 1996.
19. G. Adomian, "Vibration in offshore structures: an analysis for the general non-linear stochastic case - part I," Math. Comput. Simul., vol. 29, no. 2, pp. 119–122, 1987, doi: [https://doi.org/10.1016/0378-4754\(87\)90102-9](https://doi.org/10.1016/0378-4754(87)90102-9).
20. G. Adomian, "Vibration in offshore structures — part II," Math. Comput. Simul., vol. 29, no. 5, pp. 351–356, 1987, doi: [https://doi.org/10.1016/0378-4754\(87\)90070-X](https://doi.org/10.1016/0378-4754(87)90070-X).
21. J. Penzien and S. Tseng, "Three-dimensional dynamic analysis of fixed offshore platforms," in Numerical Methods in Offshore Engineering, O. C. Zienkiewicz, R. W. Lewis, and K. G. Stagg, Eds. New York: John Wiley & Sons, 1979.
22. J. Thomas and B. Abbas, "Finite element model for dynamic analysis of Timoshenko beam," J. Sound Vib., vol. 41, no. 3, pp. 291–299, 1975, doi: [https://doi.org/10.1016/S0022-460X\(75\)80176-3](https://doi.org/10.1016/S0022-460X(75)80176-3).
23. R. W. Clough and J. Penzien, Dynamics of structures. McGraw Hill, 1993.
24. K. J. Bathe, Finite element procedures. Prentice Hall, 1996.
25. A. S. Veletsos and B. Verbic, "Basic response functions for elastic foundations," J. Eng. Mech., vol. 100, no. 2, pp. 1227–1248, 1974, doi: <https://doi.org/10.1061/JMCEA3.0001869>.
26. N. C. Tsai, "Modal damping for soil - structure interaction," J. Eng. Mech., vol. 100, no. 2, pp. 323–341, 1974.
27. A. K. Malhotra and J. Penzien, "Nondeterministic analysis of offshore structures," J. Eng. Mech., vol. 96, no. 6, pp. 985–1003, 1970.
28. A. G. Davenport, "The spectrum for horizontal gustiness near the ground in high wind," Q. J. R. Meteorol. Soc., vol. 87, pp. 194–211, 1961.

APPENDIX

The excitation force vector \mathbf{P}_i (Eq. (5)) at the i th submerged node of the platform is defined by the modified Morison formula (see [1], [6], [17], [21]):

$$\mathbf{P}_i = \mathbf{P}_{p_i} + \mathbf{P}_{a_i} + \mathbf{P}_{d_i} \quad (\text{A.1})$$

where $\mathbf{P}_{p_i} = C'_M \rho V_i \dot{\mathbf{v}}_{n_i}$, $\mathbf{P}_{a_i} = C''_M \rho V_i (\dot{\mathbf{v}}_{n_i} - \dot{\mathbf{q}}_{n_i})$,

$$\mathbf{P}_{d_i} = 1/2 C_D \rho A_i [(\mathbf{v}_{n_i} - \dot{\mathbf{q}}_{n_i}) | (\mathbf{v}_{n_i} - \dot{\mathbf{q}}_{n_i}) |] \approx \approx K_{D_i} (\mathbf{v}_{n_i} | \mathbf{v}_{n_i} | - 2 | \mathbf{v}_{n_i} | \dot{\mathbf{q}}_{n_i}),$$

ρ is the density of water, V_i , A_i are the volume and projected area associated with the i th node, $K_{D_i} = 1/2 C_D \rho A_i$, \mathbf{v}_{n_i} and $\dot{\mathbf{q}}_{n_i}$ are fluid particle velocity and structural velocity vectors at node i , "n" denotes normal to the cylinder axis, C'_M , C''_M , C_D are empirical coefficients affected by the cross-sectional shape, Reynolds and Keulegan-Carpenter numbers, and relative roughness (see [8], [9]).

Equation (A.1) takes the form:

$$\mathbf{P}_i = K_{M_i} \dot{\mathbf{v}}_{n_i} - K_{M_i}^a \ddot{\mathbf{q}}_{n_i} + K_{D_i} (\mathbf{v}_{n_i} | \mathbf{v}_{n_i} | - 2 | \mathbf{v}_{n_i} | \dot{\mathbf{q}}_{n_i}) \quad (\text{A.2})$$

where $K_{M_i} = C_M \rho V_i$, $C_M = (C'_M + C''_M)$, $K_{M_i}^a = C''_M \rho V_i$.

Assuming that the wave-particle kinematics is represented by a zero-mean stationary ergodic Gaussian stochastic process, the i th damping coefficient $2K_{D_i} | \mathbf{v}_{n_i} |$ takes the form [17]:

$$\begin{aligned} 2K_{D_i} | \mathbf{v}_{n_i} | \dot{\mathbf{q}}_{n_i} &= 2K_{D_i} E[| \mathbf{v}_{n_i} |] \dot{\mathbf{q}}_{n_i} + 2K_{D_i} \{ | \mathbf{v}_{n_i} | - E[| \mathbf{v}_{n_i} |] \} \dot{\mathbf{q}}_{n_i} \\ &= K_{D_i} \sqrt{8/\pi} \sigma_{v_{n_i}} \dot{\mathbf{q}}_{n_i} + 2K_{D_i} \left[| \mathbf{v}_{n_i} | - \sqrt{2/\pi} \sigma_{v_{n_i}} \right] \dot{\mathbf{q}}_{n_i} \end{aligned} \quad (\text{A.3})$$

where $E[| \mathbf{v}_{n_i} |] = \sqrt{2/\pi} \sigma_{v_{n_i}}$ is the mean value of $| \mathbf{v}_{n_i} |$ and $\sigma_{v_{n_i}} \approx \sigma_{v_{n_i} - \dot{\mathbf{q}}_{n_i}}$ is the standard deviation of the water-particle velocity vector.

The second term of Eq. (A.2), i.e., $K_{M_i}^a \ddot{\mathbf{q}}_{n_i}$, is called the added mass term, while the first term of Eq. (A.3), i.e., $K_{D_i} \sqrt{8/\pi} \sigma_{v_{n_i}} \dot{\mathbf{q}}_{n_i}$ is the hydrodynamic damping term. These two terms are added to the corresponding structural mass (Eq. (3)) and damping matrices (Eq. (4)).

Considering the second term of Eq. (A.3) to be small (the fluctuating damping), the wave force \mathbf{P}_i reads:

$$\begin{aligned} \mathbf{P}_i &= K_{M_i} \dot{\mathbf{v}}_{n_i} + K_{D_i} \sqrt{8/\pi} \sigma_{v_{n_i}} \mathbf{v}_{n_i} - \varepsilon \left(2K_{D_i} \left[| \mathbf{v}_{n_i} | - \sqrt{2/\pi} \sigma_{v_{n_i}} \right] \dot{\mathbf{q}}_{n_i} \right) \\ &= \mathbf{P}_{0i} + \varepsilon \mathbf{P}_{1i} \end{aligned} \quad (\text{A.4})$$

where

$$\begin{aligned} \mathbf{P}_{0i} &= K_{M_i} \dot{\mathbf{v}}_{n_i} + K_{D_i} \sqrt{8/\pi} \sigma_{v_{n_i}} \mathbf{v}_{n_i}, \mathbf{P}_{1i} = \\ &= -2K_{D_i} \left[| \mathbf{v}_{n_i} | - \sqrt{2/\pi} \sigma_{v_{n_i}} \right] \dot{\mathbf{q}}_{n_i} \end{aligned}$$

The stochastically linearised wind force vector \mathbf{P}_j at the j th node above the sea water level takes the form (see [6]):

$$\mathbf{P}_j(t) = A \rho_A C_{DA} \left[1/2 | \bar{\mathbf{v}}_j | \bar{\mathbf{v}}_j + \left(| \bar{\mathbf{v}}_j | + \sqrt{1/2\pi} \sigma_{v'_m v'_m} \right) \mathbf{v}'_j \right] \quad (\text{A.5})$$

where A denotes the windward area of the platform, $\rho_A = 1.23 \text{ kg/m}^3$ is the air density, C_{DA} is the drag coefficient, $\bar{\mathbf{v}}_j$ and \mathbf{v}'_j are the mean value and the fluctuating part of the wind velocity vector, respectively, $\sigma_{v'_m v'_m}$ is the standard deviation of the fluctuating wind velocity for two points m and n on a vertical plane perpendicular to the mean wind velocity and $\sigma_{v'_m v'_m}^2 = \int_0^\infty S_{v'_m v'_m}(\omega) d\omega$, where $S_{v'_m v'_m}(\omega)$ is a single-sided Davenport spectrum [28].

CONTACT WITH THE AUTHOR

Bogdan Rozmarynowski
e-mail: bogrozma@pg.edu.pl

Gdańsk University of Technology
Narutowicza 11/12
80-233 Gdańsk
POLAND