

Shape coefficient in the inland vessel resistance prediction

Maciej Zawiślak, Ph.D.
Wrocław University of Technology

Abstract

In recalculation of a model resistance into a real object resistance, one of difficult to estimate values is the shape coefficient. There are well known and tested methods of determining the $(1+k_0)$ coefficient for sea-going ships. In the case of inland vessels navigating in the limited depth waterways the problem has not been solved completely. The paper presents results of computations of the inland vessel shape coefficient determined by means of numerical methods (MOS). The shape coefficient has been calculated as a function of the block coefficient and block coefficient of the forebody of a barge hull. The calculations were based on five typical shapes of the transport inland vessels and were carried out for different depth to draught (h/T) ratios and different sailing speeds.

Keywords: shape, ships, inland vessel, resistance prediction, MOS

INTRODUCTION.

In predicting the ship resistance, the viscous resistance component is determined as resistance of an equivalent flat plate. The specific flat plate frictional resistance is most often determined from the ITTC 57 expression:

$$c_{FO} = \frac{0,075}{(\log_{10} Re - 2)^2} \quad (1)$$

In order to allow for a space body form of ship, the shape coefficient has been introduced. The form of shape coefficient is given in expression (2):

$$(1 + k_0) = \frac{c_v}{c_{FO}} \quad (2)$$

The coefficient is a ratio of the hull viscous frictional resistance to the flat plate viscous resistance.

Expression (2) cannot be used for resistance calculations by the classical Froude method as model tests do not allow to subdivide the total force into the normal and tangent resistance components. In practice, formulae are used for the shape coefficient as a function of the hull geometric characteristics. Expression (2) may be used in the CFD numerical methods.

The shape coefficients for resistance calculations in deep water are given by the formulae:

$$k_0 = 18,7 \cdot \left(C_B \frac{B}{L_w} \right)^2 \quad (3)$$

$$k_0 = 0.017 + 20 \frac{C_B}{\left(\frac{L_w}{B} \right)^2 \sqrt{T}} \quad (4)$$

Table 1. Dependence of the shape coefficient on h/T

h/T	$1+k_0$
>3,0	1,12
2,0	1,24
1,5	1,32

The shallow water shape coefficient $(1 + k_0)$ is taken from Table 1:

Proceedings of the 23rd ITTC [1] recommend determination of the shape coefficient from:

$$k_{0h} = k_{0\infty} + 0.644 \left(\frac{T}{h} \right)^{1.72} \quad (5)$$

During recalculation of the model resistance force into the real object resistance in a restricted waterway, the use of shape coefficients may lead to negative values of the residuary resistance [2].

Numerical calculations, results.

In order to test the influence of shape coefficient in shallow water on the total resistance, flow around the OBM shape with different forebodies was analysed (Fig. 1). A barge of a constant length and the same shape of middlebody and afterbody was used. The analysis was carried out for the draught $T = 1.6$ m and two waterway depths: $h = 2.0$ m and $h = 2.5$ m.

The FLUENT system computations gave the total resistance force and its resolution into a normal and a tangent to the hull surface component. From that the shape coefficient was determined in accordance with formula (2), where c_v was found from

the viscous (tangent) resistance values calculated in the FLUENT system and c_{FO} from (1). Additionally, for comparison, the shape coefficient values were calculated from formulae (3), (4), (5)+(3) and (5)+(4). The shape coefficient (2) depends on the sailing speed and the other formulae make the shape coefficient dependent on the ship hull geometric parameters. The computation results are presented in Tables 2 and 3. Additionally calculations were carried out for two model scales: 1:8 and 1:24. The shape coefficient as described by (2) increases with the increasing sailing speed. It may also be noticed that the shape coefficient increases with model size (decreasing model scale). The shape coefficient (2) variation range is large, equal 1.31 to 0.44 for $h = 2.0$ m and 1.28 to 0.58 for $h = 2.5$ m. The main shape parameter in the case of the change of forebody is the block coefficient. It may be assumed that the shape coefficient depends only on the block coefficient of the forebody. When the block coefficient increases, the shape coefficient value decreases.

The shape coefficient increases with the waterway depth h at a constant ship draught T and the increase is greater for greater block coefficient values, e.g. the PION shape, and for smaller block coefficient values, e.g. the PODC shape, it is practically constant or even decreases slightly.

The difference between the shape coefficient extreme values calculated from formulae (4) and (5)+(3) (Table 2) for $h = 2.0$ m is 47-49% and for $h = 2.5$ m (Table 3) is 35-37%.

The shape coefficient in Tables 2 and 3 is shown from the smallest to the greatest value acc. to (1). Such order coincides with the shape resistance quality from the best to the worst. The smallest resistance value was obtained from the PODC and OBM shapes and the greatest value from the PION shape. Fig. 2

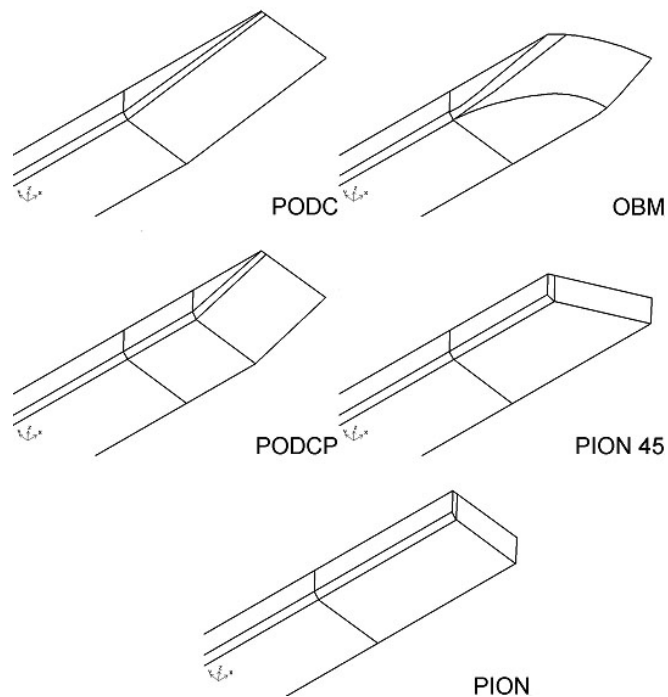

Fig. 1. OBM with different forebodies

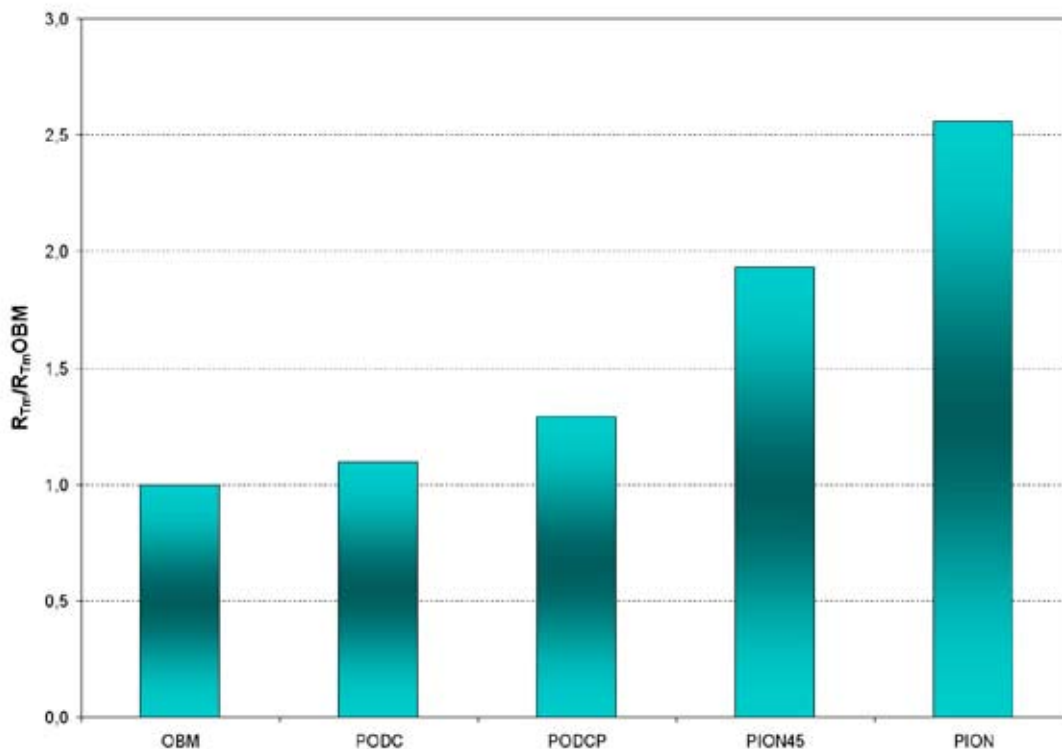

Fig. 2. Change of the total resistance for the OBM shape with different forebodies. $h=2.0$ m, $T=1.6$ m, scale 1:8, $V_m=0.491$ m/s

and Fig. 3 present the total resistance of a model in relation to the total resistance of the OBM model. The OBM shape had the best resistance quality. The results are shown for the 1:8 scale.

The shape resistance calculations were carried out and shape coefficients determined for the OBM, SFKO, Z1-Z4, B_170, Duisburg [2] barges. From the shape coefficients (2) a “map” of relations with the block coefficient of the forebody CB_D (Fig. 4) and the hull block coefficient CB (Fig. 5) was drawn. All the shape coefficient values for all the analysed shapes with different draught, waterway depth and sailing speed were plotted on the diagrams. Values for different shapes are marked differently. The

Table 2. Shape coefficients for OBM – forebodies $h = 2.0$ m and $T = 1.6$ m

PODC						CB=0,858	CB _D =0,912
scale	V	1+k ₀	1+k ₀	1+k ₀	1+k ₀	1+k ₀	1+k ₀
	m/s	(2)	(3)	(4)	(5)+(3)	(5)+(4)	Tab. 1
8	0,491	1,29	1,24	1,14	1,68	1,58	1,41
24	0,284	1,22					
8	0,687	1,3					
24	0,397	1,25					
8	0,884	1,31					
24	0,51	1,26					
OBM						CB=0,878	CB _D =0,937
scale	V	1+k ₀	1+k ₀	1+k ₀	1+k ₀	1+k ₀	1+k ₀
	m/s	(2)	(3)	(4)	(5)+(3)	(5)+(4)	Tab. 1
8	0,491	1,28	1,25	1,15	1,69	1,58	1,41
24	0,284	1,2					
8	0,687	1,29					
24	0,397	1,23					
8	0,884	1,31					
24	0,51	1,25					
PODCP						CB=0,890	CB _D =0,953
scale	V	1+k ₀	1+k ₀	1+k ₀	1+k ₀	1+k ₀	1+k ₀
	m/s	(2)	(3)	(4)	(5)+(3)	(5)+(4)	Tab. 1
8	0,491	1,19	1,26	1,15	1,69	1,59	1,41
24	0,284	1,14					
8	0,687	1,2					
24	0,397	1,16					
8	0,884	1,21					
24	0,51	1,17					
PION45						CB=0,904	CB _D =0,970
scale	V	1+k ₀	1+k ₀	1+k ₀	1+k ₀	1+k ₀	1+k ₀
	m/s	(2)	(3)	(4)	(5)+(3)	(5)+(4)	Tab. 1
8	0,491	0,73	1,26	1,15	1,7	1,59	1,41
24	0,284	0,7					
8	0,687	0,74					
24	0,397	0,72					
8	0,884	0,74					
24	0,51	0,73					
PION						CB=0,923	CB _D =0,993
scale	V	1+k ₀	1+k ₀	1+k ₀	1+k ₀	1+k ₀	1+k ₀
	m/s	(2)	(3)	(4)	(5)+(3)	(5)+(4)	Tab. 1
8	0,491	0,44	1,28	1,15	1,71	1,59	1,41
24	0,284	0,46					
8	0,687	0,45					
24	0,397	0,46					
8	0,884	0,45					
24	0,51	0,46					

Fig. 4 diagram may be divided into three areas. For the block coefficient value up to 0.96 the shape coefficient is greater than 1, for the block coefficient in the 0.96 to 0.985 range the shape coefficient is greater or less than 1 and for the block coefficient above 0.985 the shape coefficient is less than 1.

The whole diagram has a clear direction. In general, when the block coefficient increases the shape coefficient decreases. When the block coefficient decreases the shape coefficient should approach the value 1, which it will reach with $CB = 0$, i.e. for a flat plate.

Fig. 5 presents the same results but as a function of the hull block coefficient. Two areas may be distinguished here by the hull shape. OBM and BM Duisburg are motor barges, the other are pushed barges. The diagram shows that not only the forebody

Table 3. Shape for OBM – forebodies $h = 2.5$ m and $T = 1.6$ m

PODC						CB=0,858	CB _p =0,912
scale	V	1+k ₀	1+k ₀	1+k ₀	1+k ₀	1+k ₀	1+k ₀
	m/s	(2)	(3)	(4)	(5)+(3)	(5)+(4)	Tab. 1
8	0,491	1,27	1,24	1,14	1,54	1,44	1,31
24	0,284	1,23					
8	0,687	1,28					
24	0,397	1,25					
8	0,884	1,28					
24	0,51	1,26					
OBM						CB=0,878	CB _p =0,937
scale	V	1+k ₀	1+k ₀	1+k ₀	1+k ₀	1+k ₀	1+k ₀
	m/s	(2)	(3)	(4)	(5)+(3)	(5)+(4)	Tab. 1
8	0,491	1,26	1,25	1,15	1,55	1,44	1,31
24	0,284	1,23					
8	0,687	1,27					
24	0,397	1,24					
8	0,884	1,28					
24	0,51	1,25					
PODCP						CB=0,890	CB _p =0,953
scale	V	1+k ₀	1+k ₀	1+k ₀	1+k ₀	1+k ₀	1+k ₀
	m/s	(2)	(3)	(4)	(5)+(3)	(5)+(4)	Tab. 1
8	0,491	1,22	1,26	1,15	1,55	1,45	1,31
24	0,284	1,2					
8	0,687	1,23					
24	0,397	1,21					
8	0,884	1,24					
24	0,51	1,22					
PION45						CB=0,904	CB _p =0,970
scale	V	1+k ₀	1+k ₀	1+k ₀	1+k ₀	1+k ₀	1+k ₀
	m/s	(2)	(3)	(4)	(5)+(3)	(5)+(4)	Tab. 1
8	0,491	0,83	1,26	1,15	1,56	1,45	1,31
24	0,284	0,84					
8	0,687	0,84					
24	0,397	0,86					
8	0,884	0,85					
24	0,51	0,87					
PION						CB=0,923	CB _p =0,993
scale	V	1+k ₀	1+k ₀	1+k ₀	1+k ₀	1+k ₀	1+k ₀
	m/s	(2)	(3)	(4)	(5)+(3)	(5)+(4)	Tab. 1
8	0,491	0,58	1,28	1,15	1,57	1,45	1,31
24	0,284	0,59					
8	0,687	0,58					
24	0,397	0,59					
8	0,884	0,58					
24	0,51	0,6					

but also the afterbody shape is important.

The presented shape coefficient “map” shows that the coefficient value may be below one. The classical methods of the coefficient determination will not yield such a value. The use of expression (2) is difficult as it is possible only when the total resistance force is divided into the viscous resistance and normal resistance, which is not achieved in the classical model tests. The above presented results should not be treated as precise, but only as a tendency of the shape coefficient changes as a function of the block coefficient.

The diagrams do not show the shape coefficient as a function of the h/T ratio as the respective results are not unequivocal.

Summary.

- Value of the shape coefficient decreases with the increase of block coefficient and may assume a less than 1 value. These results are significantly different from those obtained from the currently used expressions.
- The value of shape coefficient according to definition (1) depends on the sailing speed, which is not allowed for in the classical empirical formulae. The shape coefficient acc. to (2) increases with the increased sailing speed.
- The greater the shape coefficient value the better the barge shape in terms of resistance (Fig. 2) and (Fig. 3).
- The shape coefficient value increases with the model size (decreasing model scale).
- Relation of the shape coefficient and the h/T ratio for different barge shapes is not unequivocal.

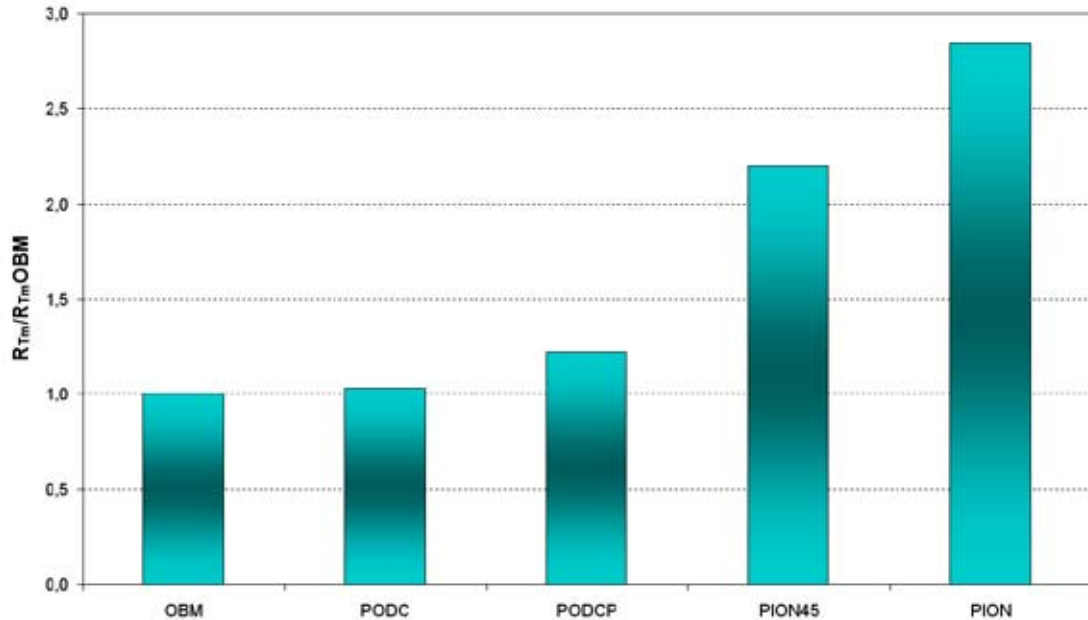

Fig. 3. Change of the total resistance for OBM with different forebodies. $h=2.5$ m, $T=1.6$ m, scale 1:8, $V_m=0.491$ m/s

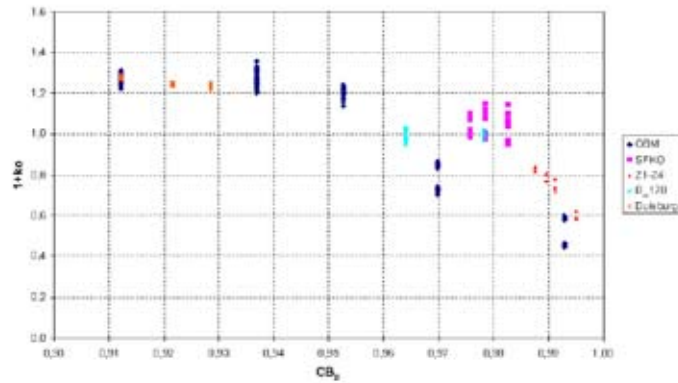

Fig. 4. The shape coefficient as a function of the forebody block coefficient CB_p

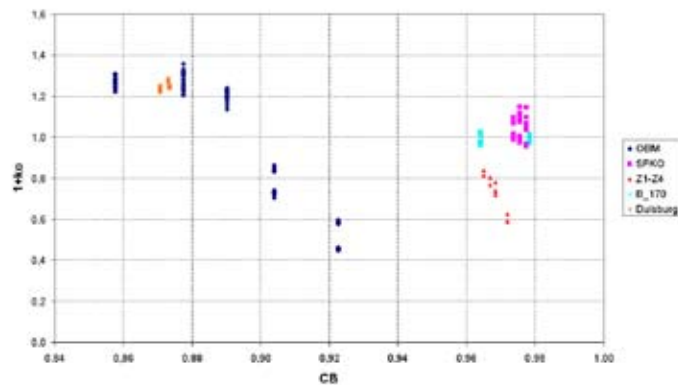

Fig. 5. The shape coefficient as a function of the hull block coefficient CB

Bibliography.

- [1] ITTC, 23rd International Towing Tank Conference, Proceedings of the 23rd ITTC, 2002.
[2] Zawiślak Maciej, Influence of the depth of waterway on the viscous resistance of an inland vessel, Doctor's thesis, Wrocław 2004.

NOMENCLATURE:

$1+k_0$ – shape coefficient

c_v – specific viscous frictional resistance

c_{FO} - specific flat plate frictional resistance

c_B – block coefficient

c_{BD} – block coefficient of the forebody

B – ship breadth

L_w – ship length on waterline

T – ship draught

h – depth of waterway

