

Selected problems of determining an efficient operation standard in contemporary heat-and-flow diagnostics

Jerzy Głuch

Abstract

In this paper are specified causes of ambiguities and difficulties in determining an efficient operation standard for land and marine turbine power plants. Two of them, namely: lowering values of working media inlet parameters and changes in configuration of connections between component devices of thermal cycles, have been analyzed. As a remedy for resulting difficulties a thermal cycle computational model of modular structure has been proposed. As showed, the tuning of the computational model with respect to correct measurements by elaborating individual corrections for calculation coefficients of computational methods used for particular devices ensures good accuracy of determination of unserviceability symptoms in these conditions. Introduction to the modular computational model – of control modules making use of valve opening indicators in DCS system ensures good accuracy also in the case of changes in structure of complex power object.

Keywords: steam turbines, operation of turbines, power units, thermal measurements, thermal diagnostics, diagnostic relations

Introduction

Heat-and-flow diagnostics belongs to such forms of process diagnostics, in which the diagnostic method based on application of a standard, turns out to be useful, Fig. 1. As it belongs to process diagnostics its main task is to assess efficient run of energy transformation in turbine thermal cycles [2, 5, 8, 10, 12, 13, 15, 21]. Such standard is that of efficient work of operationally undegraded object [5, 10, 15].

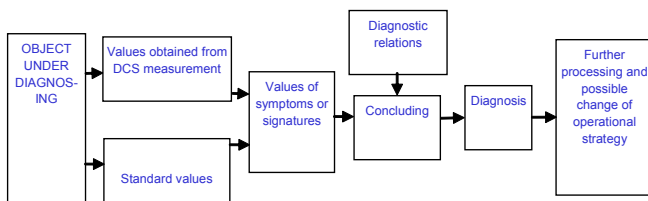

Fig. 1. Schematic diagram of diagnosing process based on a standard

Heat-and-flow diagnostics is intended for the determining of efficient operation of power plants fitted with thermal turbines. Turbine engines are applied to land and marine power plants. In the case of steam turbine power plant, its equipment with many measuring instruments is characteristic both in land applications, [4, 7, 9, 10, 11, 14, 16, 20], Fig. 2, and marine ones [3, 6], Fig. 3. The equipment is available in the frame of Distributed Control System (DCS) [1, 14, 16, 17, 18, 19]. It makes good prospects for diagnosing objects of both kinds by using an efficient operation standard.

Inefficient work of steam power plant results from operational degradation of geometry of component devices of thermal cycle. Control of efficient run of energy transformations in power plant consists in examining signatures consisted of inefficient work symptoms. Every symptom determines deviation of value of heat-and-flow parameter corresponding to it (mass flow, pressure, temperature), or characteristics (e.g. efficiency, steam flow capacity of particular component elements) from a reference value characteristic for undegraded object.

The above presented description seems to be simple but only in the case of object working in stable conditions and with its unchangeable structure. Yet steam turbine power plant (both land and marine one) is characteristic of:

- varying conditions of the loading of the power plant, and of its environment,
- dependence of power plant operational parameters on changes in its loading and environment,
- dependence of power unit's operational parameters on operational degradation of geometry of component devices.

It leads to difficulties in making diagnosis.

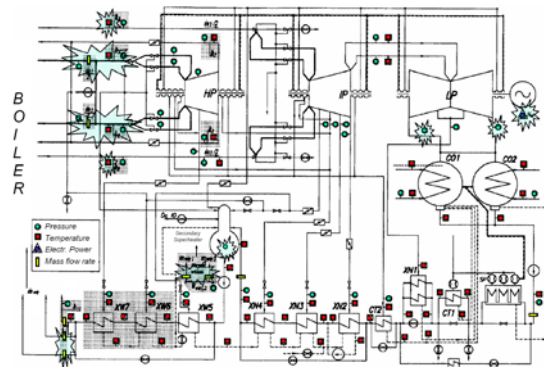

Fig. 2. An example of thermal cycle configuration and arrangement of measurement instruments in a high-power unit of an electric power station

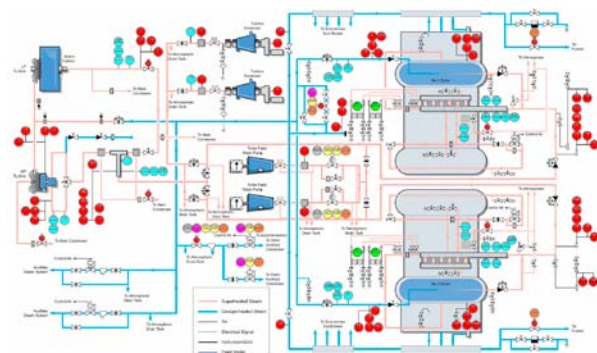

Fig. 3. An example of arrangement of control-measurement instruments (represented by colour circles) in steam power plant of one of contemporary steam turbine ships [6]

To obtain an unambiguous diagnosis, symptoms and signatures should be so formed as to get them depending on all characteristic states of operation. As acquisition of measurement results is performed with taking into account all the states it means that the same requirement is imposed on the standard. Therefore the standard-based diagnostics requires to have:

- an efficient operation standard which reflects dependence of changes of parameters on current load state,
- an efficient operation standard which reflects structure of a given object.

Such aims are fulfilled by a standard of functional type, having modular structure, which makes it possible:

- to identify measurement points,
- to imitate (reproduce) object's structure and,
- to calculate distribution of measured parameters in function of power unit's load and environmental conditions.

Hence every change in mode of operation leads to determination of a new reference state, i.e. a new standard.

The first of the considered situations which complicate diagnosis making, arises when periodical limitations of power unit operational parameters occur or when configuration of connections between the unit's devices should be periodically changed. The second situation takes place when a fault measurement gauge should be replaced by a new one.

The third case concerns a machine in which only some of its degraded component devices were repaired.

A separate problem is to elaborate a standard, i.e. a reference state for on-line diagnostics. This paper is aimed at analyzing the first of the considered disturbances in operation of steam turbine plants. In the case of land power plants limitations of parameters may occur if there is a need to operate a non-fully serviceable object provided it is approved by its manufacturer. In practice are more and more often met circumstances to change configuration of feed component devices, which occur in the case of significant power limitation of the power unit. In the case of ship power plants the necessity to continue ship voyage under limited steam boiler parameters sometimes appears. In some cases it is necessary to keep ship propulsion system working at delivery of power from only one turbine cylinder. For these considerations 200 MW power unit cycle whose schematic diagram is presented in Fig.2, was selected. For this cycle influence of limitations of parameters and selected changes in configuration were analyzed, and selected results of simulation calculations have been presented here.

Investigated object

In Fig. 2 schematic thermal diagram of the 200 MW

power unit is presented. The arrangement of measurement instruments intended for measuring the heat-and-flow parameters such as: pressure, temperature, mass flow rates and – additionally– also electric output power, is given. Majority of the parameters is dependent on load state and environmental conditions of the object. And, a part of them just indicates the load and environmental conditions, and to consider them as independent parameters, is possible. For the 200 MW condensation steam power unit the following parameters belong to the dependent ones:

- electric generator output power or live steam mass flow rate, alternatively,
- live steam pressure,
- live steam temperature,
- interstage superheat temperature,
- condensation pressure,
- pressure in the degasifier (since the constant -pressure degasifier is applied),
- rate of water jet to live steam superheater,
- rate of water jet to reheat steam superheater.

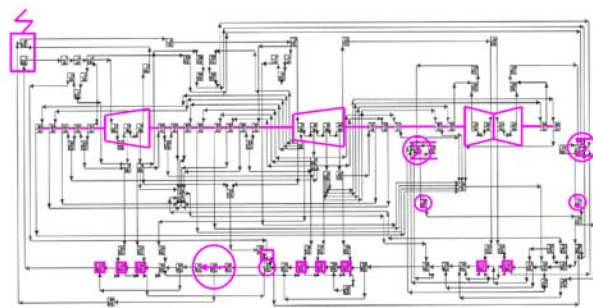

Fig. 4. Illustration of numerical calculation scheme of the power unit [5, 10]

The measurement points of these quantities are indicated by irregular asterisks in the schematic diagram, Fig.2. Results of the measurements can be used to calculate the cycle efficiency characteristics. Measurement results of the dependent parameters together with the so determined characteristics can be taken as current values in heat-and-flow diagnostics. They next serve for determining inefficient operation symptoms.

The efficient operation standard can be determined computationally. For this purpose the steam power plant calculation model [5, 8, 10, 15] as well as the DIAGAR numerical calculation program [5] intended for balancing thermal cycles and performing their diagnostics, can be used. Fig.4 shows graphically the calculation model of the power plant presented in Fig. 2. Every square symbolizes a calculation procedure for particular component devices of the cycle, which makes use of geometrical and flow data of a given device, whereas the connecting lines reproduce structure of the power plant. With the use of the schematic diagram measurement points of heat-and-flow parameters can be identified. After introduction of independent parameters to the calculations, by hand or directly from DCS system, dependent values, including those associated

with measurement points, are calculated. Reference (standard) values are determined by taking into account undegraded geometry of component devices.

The calculation program fulfils role of the efficient operation standard. It is a kind of functional standard. It makes it possible to calculate reference values in function of changes of independent parameters. Structure of the model is flexible and allows to introduce modifications. Partial calculation models of the devices are susceptible to tuning [8, 10]; they can be tuned on the basis of correct experimental results and are characterized by accurate, i.e. convergent with the experiment, calculation results of heat-and-flow quantities [10, 15]. The tuning of model consists in determination of corrections to experimental coefficients appearing in calculation methods. The corrections take into account all phenomena which cause differences between measurement results and relevant calculation results. Such corrections for two flow coefficients: μ_1 and μ_2 , and two velocity coefficients: φ and ψ , were prepared for turbine stages, as well as the heat transfer coefficient k – for heat exchangers [10, 15]. The calculation model tuned with their use satisfies the above mentioned requirements for efficient operation standards.

Application of efficient operation standard in the case of external limitations imposed on power unit operational parameters

In service conditions such situations -usually resulting from minor failures -happen that power generation objects operate at limited inlet parameters of working media because of cost of long -lasting standby periods. This has been observed in land electric power stations. In the cases known to this author live and reheat steam temperatures were decreased (sometimes even by 30°C) because of overrunning repairs of boiler superheaters. In marine conditions similar phenomena can also occur if they happen during voyage which should be continued without generating excessive risk to safety of the ship and its crew. In each of the above mentioned events to get approval to do it from the side of manufacturers of crucial devices (first of all – boiler and turbine) is necessary.

The above mentioned case of limitation of live and reheat steam temperatures is exemplified by a fragment of line of expansion within turbine, Fig. 5. The nominal temperature t_{00} was lowered to that t'_{00} . This resulted in change of run of the expansion line from the nominal state (continuous purple line) to the transient state (dashed purple line). Only minor influence on operation of the valves and control stage can be observed. In both the states the efficiency characteristics of the non-regulated part of the turbine are only slightly different. However pressure distribution within the turbine is changed distinctly. Such state of the power unit can be reproduced in the calculation model of the DIAGAR program. Hence, an efficient operation standard can be elaborated on the basis of the calculation model.

The tuning of the calculation model at limited inlet parameters is excessively time-consuming and unprofitable. Periods of such power plant operation are limited and the time-consuming process of the

tuning cannot be then started. Therefore tuning-up and corrections for the nominal state of operation at different loads should be used.

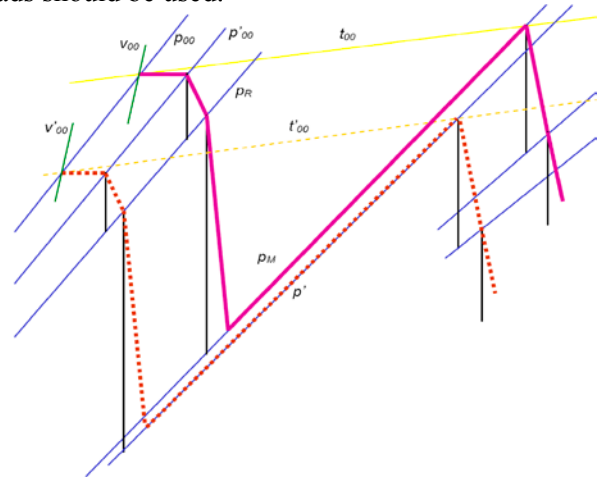

Fig. 5. Simplified schematic diagram of steam flow changes at inlets to HP and IP cylinders in the case of limited superheating temperatures

The corrections of the above mentioned coefficients of turbine stages and the heat transfer coefficients k for heat exchangers can be performed either individually or globally. The global approach consists in introducing the correction in function of the independent parameters of the cycle, as expressed by the below given relations (1)÷(5), [5, 10]:

The individual corrections (6)÷(10) are functions of the local parameters, i.e.: generalized losses – for the velocity coefficients, as well as blade geometrical parameters and Reynolds number – for the flow coefficients, and functions of the heating steam and feed water inlet parameters – for the heat transfer coefficients k for heat exchangers [10, 15]:

$$\frac{\Delta\varphi}{\varphi_{obl}} = f(p_{00}, t_{00}) \quad (1)$$

$$\frac{\Delta\psi}{\psi_{obl}} = f(p_{00}, t_{00}) \quad (2)$$

$$\frac{\Delta\mu_1}{\mu_{1obl}} = f(p_{00}, t_{00}) \quad (3)$$

$$\frac{\Delta\mu_2}{\mu_{2obl}} = f(p_{00}, t_{00}) \quad (4)$$

$$\frac{\Delta k}{k_{obl}} = f(p_{00}, t_{00}) \quad (5)$$

By making use of the global corrections and owing to compliance with experiment, to perform more accurate calculations in conditions of power plant normal load as compared with application of local corrections, is possible. However the global corrections have also

$$\frac{\Delta\varphi}{\varphi_{obl}} = f(x_1, x_2) \quad (6)$$

$$\frac{\Delta\psi}{\psi_{obl}} = f(x_1, x_2) \quad (7)$$

$$\frac{\Delta\mu_1}{\mu_{1obl}} = f(x_{1t}, BC_1, L_1, t_1, Re_1) \quad (8)$$

$$\frac{\Delta\mu_2}{\mu_{2obl}} = f(x_{2t}, BC_2, L_2, t_2, Re_2) \quad (9)$$

$$\frac{\Delta k}{k_{obl}} = f(p_p, i_p, P_{wl}, i_{wl}) \quad (10)$$

disadvantages resulting from their elaboration on the basis of the narrow changeability range of independent parameters, Fig. 6.

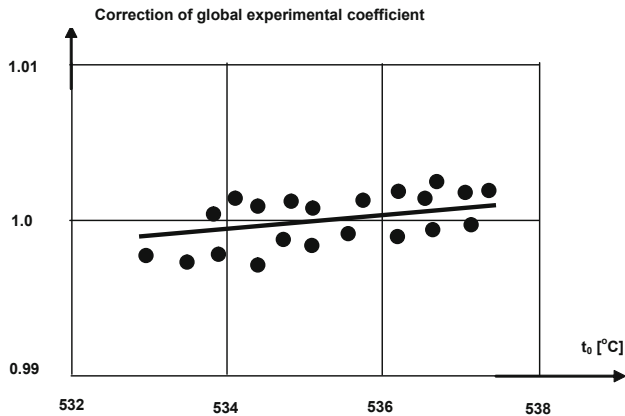

Fig. 6. Example of experimental ranges of live steam changes in conditions of normal turbine load to obtain global correction relations. [15]

The narrow range results from requirements of producers of equipment, especially boilers and turbines, who recommend to maintain values of the parameters relatively constant. It concerns live steam pressure as well as temperatures of primary and secondary superheating. And, the corrections result from regression relations. If the range used for determining the regression relations is exceeded the obtained calculation results will be loaded by large errors reaching even a few dozen percent [5, 10].

The local corrections make it possible to perform more accurate calculations in conditions of large changes of independent parameters, which distinctly exceed the ranges used in tuning the model. It results from only minor exceedance of ranges of independent variables of correction functions, Fig. 7, even at large changes of independent parameters of power plant [5, 10]. In this case linear correction functions are especially favourable [15]. The expected value of calculation errors does not exceed 1% [15].

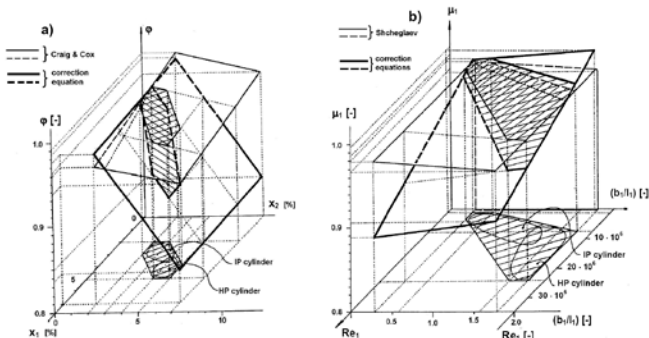

Fig. 7. Example areas of application of individual correction relations for HP and IP cylinders of steam turbine: (a) – for velocity coefficients, ϕ ; (b) – for flow coefficients, μ_1 , [10, 15]

Hence, the application of local correction makes it possible to calculate reference values and values of symptoms with a satisfactory accuracy in conditions of significant limitations of power plant independent parameters. As a matter of fact symptom determination error is greater than that in conditions of normal load but it makes it possible to use the so determined symptoms for diagnosing efficient operation of steam turbine cycles even in the so changed operational conditions.

Application of efficient operation standard in the case of cycle configuration changes

In operational practice cycle configuration changes can be met more often than the lowering of independent parameters. For land power plants for instance it concerns mode of feeding the degasifier, Fig. 8, or unsealing the valves in bypasses of heat exchangers, Fig. 9. Configuration changes often result from short current overhauls of component devices of power unit or also from producing low power. For marine power plants a change in utilization of steam for overall ship purposes or change in electric output power of turbogenerators may lead to changes in configuration of the cycle.

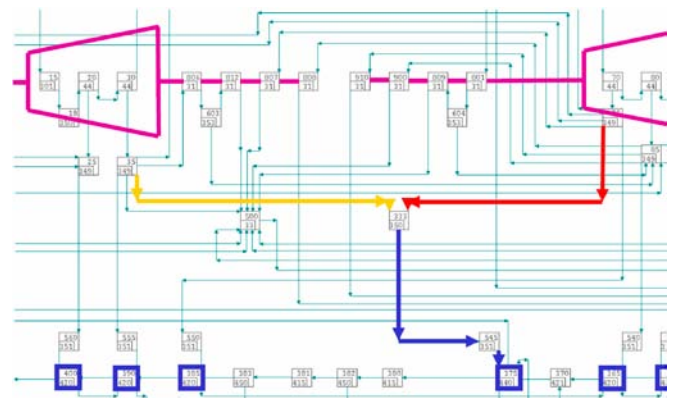

Fig. 8. A fragment of schematic diagram of power unit numerical calculations, which illustrates reproducing the cycle configuration change which consists in choice of various extractions (No. II marked 35/349, or No. III marked 75/349) for feeding the degasifier (marked 375/440), [5, 10]

In the case of possible power plant operation at configuration changes of connections between component devices, calculation procedure of reference state parameters should take into account their occurrence. The above mentioned numerical calculation program DIAGAR [5] fulfils such condition. Due to its modular structure which makes it possible to reproduce power unit's structure it can contain modules intended for the

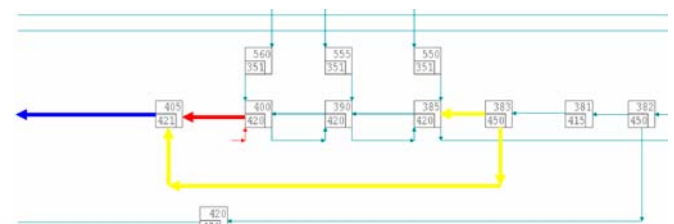

Fig. 9. A fragment of schematic diagram of power unit numerical calculations, which illustrates reproducing the cycle configuration change which consists in activation of the bypass of HP regeneration exchangers – yellow line, [5, 10]

controlling of working media flow to various devices of the power unit. The control modules of the program can be commenced manually by DIAGAR system operator, or automatically by reading valve opening indicators of DCS system. Values of dependent parameters necessary to determine inefficient operation symptoms are then calculated by such system adequately to an operational state of steam turbine power plant.

Significance of reproduction of power object structure is illustrated by the numbers which determine selected parameters of power plant and its efficiency indices, presented in Tab. 1. They are obtained by means of simulation calculations of the chosen power unit of 200 MW output. Characteristics of component devices comply with reference conditions and are not subjected to changes; the changes concern only inlet parameters or configuration. The first column deals with the operation in conditions of nominal configuration of the power unit, which consists a.o. in feeding the degasifier from the extraction III and closing all bypasses of heat exchangers. Three successive columns deal with changes in the cycle. The second one reproduces the operation of the cycle at lowered temperatures of live and reheat steam. The third one reproduces the operation of the cycle at feeding the degasifier from the extraction II. And the fourth one reproduces the operation at partial opening the bypass of HP regeneration exchangers.

Tab. 1. Changes of parameters and characteristics of 200MW power unit in the case of introduction of configuration changes with respect to nominal one

Description	Symbol	Units	Nominal configuration	Changed inlet parameters or configuration		
				Lowered temperatures: t_{00} and t_M	Feeding the degasifier from the extraction II	HP bypass active
Power	N	MW	196.700	196.700	196.700	196.700
Live steam pressure	p_{00}	MPa	12.500	12.500	12.500	12.500
Live steam temperature	t_{00}	$^{\circ}\text{C}$	539.000	500.000	539.000	539.000
Reheat steam temperature	t_M	$^{\circ}\text{C}$	539.000	500.000	539.000	539.000
Condensation pressure	p_c	kPa	9.770	9.770	9.770	9.770
Specific heat consumption	q_j	$\frac{\text{kJ}}{\text{kWh}}$	9221.000	9309.000	9238.000	9266.000
HP cyl. efficiency	η_{HP}	-	0.695	0.695	0.695	0.695
IP cyl. efficiency	η_{IP}	-	0.889	0.889	0.889	0.889
LP cyl. efficiency	η_{LP}	-	0.801	0.801	0.801	0.801
Feed water temp. after the last HP heater	$t_{aII HP}$	$^{\circ}\text{C}$	219.000	219.000	219.000	210.000
Terminal temp. differ. of the last HP heater	Γ_{HP}	$^{\circ}\text{C}$	0.107	0.107	0.107	0.107

Values of the parameters in Tab. 1 indicate that the only quantity susceptible to changes is the specific heat consumption q_j . In a content-related way it is justified because only the parameters assumed nominal and only the nominal configuration ensure to reach maximum value of object's efficiency (i.e. the lowest specific heat consumption). The remaining quantities and characteristics determined by calculation are not subjected to changes.

It shows that the use of the DIAGAR system calculation model as an efficient operation standard is correct even in changed external conditions and for operation of the cycle with changed configuration of connections between component devices.

Summary

The above presented analysis and selected results of simulation calculations indicate that there are applicable solutions which make it possible to solve certain problems concerning the power plant reference state of power objects, including marine ones. The problem is important for heat-and-flow diagnostics carried out with the use of object's efficient operation standard.

In this paper the problem of influence of limitation of values of working media inlet parameters and changes in configuration of connections between component devices of thermal cycles – with respect to conditions deemed nominal – on determining a reference state in the case of correct geometry of thermal cycle component devices, was analyzed.

It was stated that the use of the modular calculation model as an efficient operation standard makes it possible to determine the reference values in the described changeable conditions. Such model tuned to a diagnosed power plant on the basis of correct measurements at nominal configuration will comply with accuracy criteria required for that standard also in the case of changed cycle configuration.

In the case of limitation of working media inlet parameters, corrections to experimental coefficients of calculation methods should be then functions of local parameters in the surrounding of the device modeled by them. Then even large changes in power plant independent operational parameters make only slight impact on values of variables of the corrections. In simulation calculations no significant errors in determining characteristics of component devices, are observed, Tab. 1.

The modular calculation model for reproducing a modified structure of power plant should contain special modules to control calculations, depending on current cycle configuration. Control parameters can be inserted by hand. However the use of information received from contemporary DCS systems makes it possible to automate the process by gaining data from valve opening indicators. In the case of correct geometry of component devices, modification of object's structure does not change their correct characteristics, that is illustrated by the values given in Tab. 1.

Comparison of the values for the nominal configuration, given in Tab. 1, with those for the changed configuration and independent parameters shows that the using of the modular calculation model as an efficient operation standard is correct even in the case of changed external conditions and the operation with changed configuration of connections between component devices.

Bibliography

1. Abernethy R. B., Benedict R. P., Dowdell R. B.: ASME Measurement Uncertainty, Transactions of ASME, Journal of Fluids Engineering, June 1985, ASME 1985
2. Doel D. L.: Sample Analyses Including Interpretation of Residual Error, VKI Lectures Gas Turbine Condition Monitoring & Fault Diagnosis, Ed. Sieverding & Mathioudakis, ISSN0377-8312, January 13-17, Rhode Saint Genese, Belgium, Unit 4,
3. Dzida M.: On the possible increasing of efficiency of ship power plant with the system combined of marine diesel engine, gas turbine and steam turbine, at the main engine – steam turbine mode operation, Polish Maritime Research, 1/2009, Vol. 16, Gdańsk, 2009
4. Fodemski T. R., et al.: Heat measurements, Part I and II (in Polish). WNT (Scientific Technical Publishing House), Warsaw 2001
5. Gardzilewicz A., Głuch J., Bogulicz M., Uziębło W.: Correctness control of heat-and-flow measurement data gained from DCS systems of steam electric power plants (in Polish). Materials of 5th Conference on industrial process diagnostics DPP'2003, Władysławowo, 15÷17.09.2003
6. Głuch J.: Set of lectures for steam turbine power plant engineers. Unpublished internal report of Ship Automation and Turbine Propulsion Department, Faculty of Ocean Engineering and Ship Technology, Gdańsk University of Technology, Gdańsk, 2005.
7. Głuch J.: On searching-out incorrect measurements in DCS systems of power objects (in Polish). Materials of The Scientific Conference „Mechanika 2005”, Gdańsk, 04.02.2005
8. Głuch J.: Application of Artificial Neural Networks (ANN) as Multiple Degradation Classifiers in Thermal and Flow Diagnostics, TASK Quarterly 2005 No. 9, Gdańsk, 2005
9. Głuch J.: Control of heat-and-flow measurements in DCS systems of complex power objects (in Polish). Materials of The DPP'05 Conference, Rajgród, 12÷14.09.2005, Pomiary Automatyka Kontrola, Special issue, 09/2005
10. Głuch J.: A method of heat-and-flow diagnostics, which makes it possible to recognize location and degree of degradation of power turbine sets (in Polish), Series „Monographs”, No. 81, Wydawnictwo Politechniki Gdańskiej (Publishing House of Gdańsk University of Technology), Gdańsk, 2007
11. Głuch J.: Fault detection in measuring systems of power plants, Polish Maritime Research, 4/2008, Gdańsk, December 2008
12. Kosowski K.: Some aspects of vibration control; Part I: Active and passive control, Polish Maritime Research, 4/2004 (42), Vol. 11, Gdańsk, 2004
13. Kosowski K.: Some aspects of vibration control; Part II: An optimal active controller, Polish Maritime Research, 1/2005 (43), Vol. 12, Gdańsk, 2005
14. Kościelny J. M.: Development directions of decentralized automation systems (DCS) (in Polish), Pomiary Automatyka Kontrola No. 6/1998
15. Krzyżanowski J., Głuch J.: Heat-and-flow diagnostics of power objects (in Polish). Wydawnictwo Inst. Masz. Przepł. PAN (Publishing House of Institute of Fluid Flow Machinery, Polish Academy of Sciences), Gdańsk, 2004
16. Makal J.: Measurement uncertainty of multi-channel measuring system (in Polish). Pomiary Automatyka Kontrola, No. 9/2001
17. Polska Norma PR (Polish Standards): PN-EN 60953-1: PR: PN-IEC953-1, PR: PN-EN 60953-2: PR: PN-IEC953-2. Requirements for thermal acceptance tests of steam turbines. Sheet 1 and 2: Methods: A and B (in Polish), December 1998.
18. PTC6: Performance Test Code 6 on Steam Turbines ASME PTC6-2001, 1996 (Revision of ASME PTC6-1976).
19. Romessis C., Mathioudakis K.: Jet Engine Sensor Validation with Probabilistic Neural Networks. Materials of 5-th European Conference on Turbomachinery, Prague, March 17÷21, 2003
20. Ślęzak-Żoła J.: On the Application of the Artificial Neural Network Method to a Neural Simulator of Steam Turbine Power Plant, Polish Maritime Research, 1/2006, Gdańsk, January 2006
21. Żółtowski B., Ćwik Z.: Lexicon of technical diagnostics (in Polish). Wydawnictwo Uczelniane Akademii Techniczno-Rolniczej (Publishing House of Technical and Agricultural Academy of Bydgoszcz), Bydgoszcz, 1996.

Nomenclature

- b, BC – profile chord,
i – enthalpy,
k – heat transfer coefficient,
l – blade length,
p – pressure,
 p_{00} – live steam pressure,
 p_C – condensation pressure,
 p_M – reheat steam pressure,
 q_j – specific heat consumption,
t – working medium temperature or cascade pitch,
 t_{00} – live steam temperature,
 $t_{aft\ HP}$ – feed water temperature after the last HP heater,
 t_M – reheat steam temperature,
 x_1 – generalised primary profile losses,
 x_2 – generalised secondary profile losses,
 x_t – steam dryness at the end of isentropic expansion,
 Δ – deviation between actual and reference values,
 Γ_{HP} – terminal temperature difference of the last HP heater,
 φ – nozzle blade velocity coefficient,
 ψ – rotor blade velocity coefficient,
 μ – blade flow coefficient,
 η – efficiency.

Indices:

- 1 – stands for nozzle blade cascade,
2 – for rotor blade cascade,
HP – for HP turbine cylinder,
IP – for IP turbine cylinder,
LP – for LP turbine cylinder,
obl – for calculated values,
p – for steam,
w – for water.