

On the possible increasing of efficiency of ship power plant with the system combined of marine diesel engine, gas turbine and steam turbine in case of main engine cooperation with the gas turbine fed in parallel and the steam turbine

Marek Dzida, Assoc. Prof.
Janusz Mucharski, M. Sc.
Gdansk University of Technology

ABSTRACT

The article presents a concept of a combined large-power ship propulsion system, composed of the leading internal combustion main engine associated with a power gas turbine and the steam turbine system, both utilising the energy taken from the main engine exhaust gas. In the examined variant the power turbine, arranged in parallel with a turbocharger, is fed with the exhaust gas from the exhaust manifold. A calculation algorithm is presented, along with sample calculations for particular subsystems: supercharging, gas power turbine, and steam turbine system. Assumptions were formulated for the calculations, and were complemented by the adopted limits. Selected system parameters were confronted with the experimental investigations available in the literature. The performed power optimisation of the entire combined marine power plant took only into account the thermodynamic point of view, leaving aside technical and economic aspects. The numerical calculations were performed for the 52 MW low-speed marine diesel engine.

Keywords: marine power plants; combined systems; piston internal combustion engines; gas turbine; steam turbine

INTRODUCTION

Engines which are frequently used in the main propulsion systems on ships are large-power low-speed engines. Their efficiency reaches 48-51%, while large volumes of heat leave the engine with the exhaust gas. This heat can be a subject of further utilisation. Ref. [3] presents calculations of a combined power plant which consists of the main engine and the steam turbine circuit. The authors have proved that in this system, for the fuel consumption identical as for the conventional power plant the power output is increased by about 7%, while the specific fuel consumption decreases by, approximately, 6.5 %.

Due to their high efficiency, modern constructions of piston engine turbochargers do not require large volumes of exhaust gases. This provides opportunities for using a combined system which consists of an diesel engine, a power turbine, and a steam turbine.

In this situation two arrangements of the power turbine with the steam turbine are possible. In the first variant the diesel engine feeds in parallel the turbocharger and the power turbine with the exhaust gas taken from the main exhaust gas manifold. The exhaust gas from the power turbine and the turbocharger are then directed to the waste-heat boiler

which produces the steam used by the steam turbine. In the second variant, the turbocharger and the power turbine are fed in series from the diesel engine exhaust gas manifold. The exhaust gas from the diesel engine does not expand entirely to the atmospheric pressure in the turbocharger but to a higher pressure, thus leaving part of the enthalpy drop to be utilised in the power turbine. From the power turbine the exhaust gas flows to the waste-heat boiler where its heat is taken over by the steam to be used in the steam turbine to produce additional power.

The article discusses a combined system of the main engine with a turbocharger and a power gas turbine, fed in parallel from the exhaust gas manifold, and the steam turbine system. The analysed combined propulsion system has the identical main engine as that discussed in Ref. [3]. The present system was only analysed with respect to thermodynamic aspects of its application as a combined propulsion system. The required power of the gas turbine was determined for the assumed efficiencies of the turbocharger and the power turbine, while the steam turbine cycle was optimised to obtain the maximum power, assuming the use of the two-pressure waste-heat boiler. The optimisation of the steam turbine system took into account limitations resulting from practical designs used in real propulsion systems.

CONCEPT OF MARINE POWER PLANT COMBINED SYSTEM (PARALLEL POWER TURBINE FEEDING)

Fig. 1 shows a combined propulsion system for a large container ship with a marine engine. The system utilises the heat in the main engine exhaust gas. Portions of the exhaust gas which leave particular cylinders are collected in the exhaust gas manifold and then flow to a constant-pressure turbocharger. Due to high efficiency of turbochargers [1, 5], the power needed for compressing the charging air is obtained from part of the exhaust gas, the rest of which can be expanded in an additional gas turbine, a so-called power turbine, fed in parallel. The power turbine drives, as an additional drive, the propeller screw via a gear.

For partial loads, the exhaust gas flow from the main engine is not sufficient to secure the additional operation of the power turbine. In this case a control valve closes the exhaust gas inflow to the power turbine. This valve can be controlled, in the way shown in Fig. 2, by the charging air pressure signal and the propeller shaft angular speed or torque signal [2].

From the power turbine and the supercharger the exhaust gas flows to the waste-heat boiler installed in the main engine exhaust gas duct, in front of the silencer. The waste-heat boiler produces steam used both for driving the steam turbine, the power of which is used for driving the propeller screw, and for meeting general ship demands. The system provides opportunities for independent operation of the piston internal combustion engine, with the power turbine switched off. The adopted control system also makes it possible to control the operation of the supercharging system at partial loads.

The combined propulsion system includes the 9RTA-96C Sulzer main engine produced by Wärtsilä. This is a two-stroke low-speed engine, identical as that analysed in [3].

For the above main engine, the combined system calculations were performed for tropical operating conditions and two main engine loads: 100% and 90 % CMCR (Contract Maximum Continuous Rating) [3].

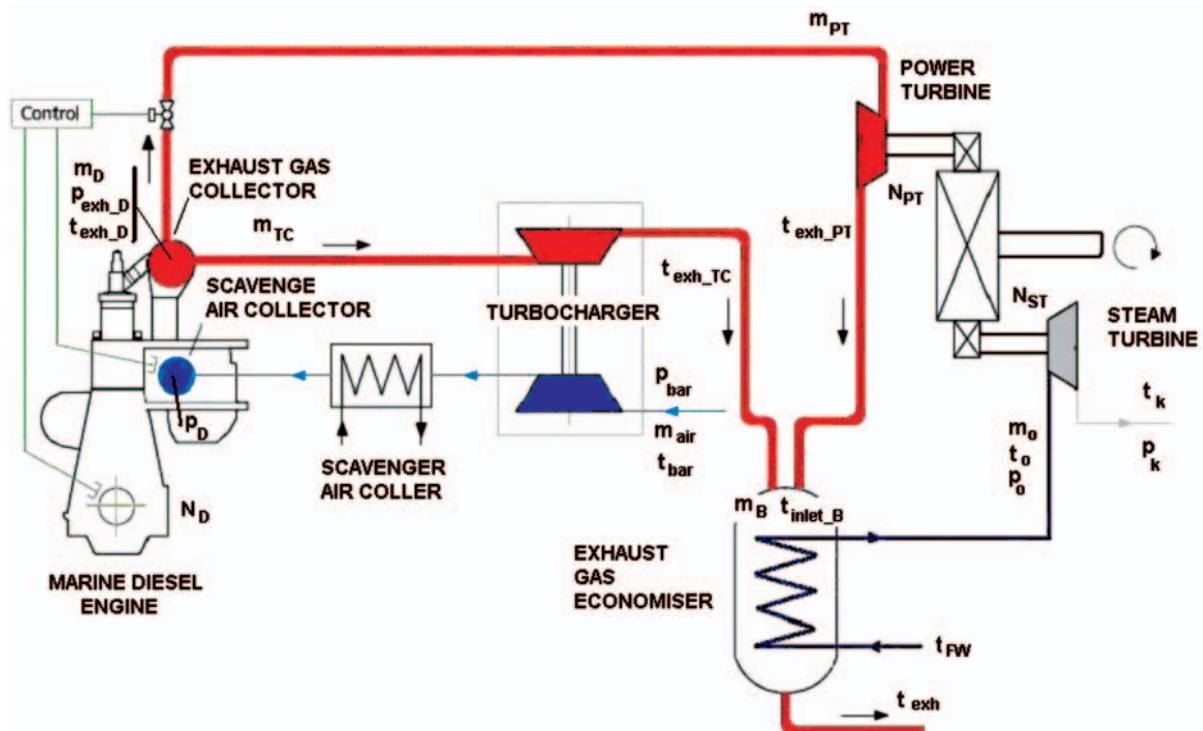

Fig. 1. Combined ship propulsion system

OPERATING CONDITIONS OF MARINE ENGINE TURBOCHARGER

The Diesel engine turbocharger delivers the mass flow rate m_{air} of the charging air, at pressure p_d , to the charging air manifold (after cooling in the charging air cooler), Fig. 1. The compressor is driven by the turbine in which the exhaust gas from the exhaust gas manifold expands.

Based on the available data, it is impossible to determine the exhaust gas temperature and pressure in front of the turbine [6]. Therefore the operating conditions of the marine engine supercharger are to be calculated [1, 2]. It was assumed that the pressure of the exhaust gas at the turbocharger turbine inlet is equal to:

$$p_{exh_D} = \zeta_1 \cdot p_d \quad (1)$$

where:

$\zeta_1 = 0.97 \div 0.98$ – exhaust gas manifold loss coefficient.

The exhaust gas pressure at turbocharger exit is:

$$p_{exh_TC} = p_{bar} + \Delta p_{exh} \quad (2)$$

where:

Δp_{exh} – pressure increment needed to force the exhaust gas flow through the waste-heat boiler.

The loss of this pressure is assumed at the level of $1.5 \div 3.5\%$ of the barometric pressure:

$$\Delta p_{exh} = \begin{cases} 0.015 \div 0.03 \text{ bar acc.to [6] and [7]} \\ 0.03 \div 0.035 \text{ bar acc.to [4]} \end{cases}$$

The temperature of the exhaust gas in front of the turbocharger (in the exhaust gas manifold, Fig. 1) is calculated from gas expansion in the turbocharger turbine:

$$t_{exh_D} = \frac{t_{exh_TC} + 273.15}{1 - \eta_T \cdot \left(1 - \frac{1}{\pi_T^{\frac{\kappa_T - 1}{\kappa_T}}} \right)} - 273.15 \text{ [}^\circ\text{C]} \quad (3)$$

where:

- η_T – turbocharger turbine efficiency
- $\pi_T = p_{inlet_TC} / p_{exh_TC}$ – turbine expansion ratio.

Fig. 2 presents temperature changes in the exhaust gas manifold:

- t_{exh_D} – (calculated) and the temperature of the exhaust gases behind the turbocharger
- t_{exh_TC} – given by the producer [6], as a function of the main engine load.

The exhaust gas flow needed for turbocharger operation is determined from the turbocharger power balance, Fig. 1, using the following formula:

$$\bar{m} \equiv \frac{m_{TC}}{m_{air}} = \frac{1 - \frac{1}{\pi_T^{\kappa_T - 1}}}{\pi_C^{\frac{\kappa_p - 1}{\kappa_p}} - 1} \cdot \frac{T_{exh_D}}{T_{bar}} \cdot \frac{c_g}{c_a} \cdot \eta_{TC} \quad (4)$$

where:

- $\eta_{TC} = \eta_T \cdot \eta_C \cdot \eta_m$ – turbocharger efficiency
- $\pi_C = p_{exh_C} / p_{bar}$ – turbocharger compressor compression ratio.

From the turbocharger, the exhaust gas flow m_{TC} having the temperature t_{exh_TC} is directed to the waste-heat boiler.

POWER TURBINE CALCULATIONS

The power turbine is fed with the exhaust gas from the exhaust gas manifold. The exhaust gas flow m_{PT} has the temperature t_{exh_D} identical as that in the turbocharger, Fig. 1. The mass flow rate of the exhaust gas to the power turbine was calculated from the relation:

$$m_{PT} = m_{air} \cdot (1 - \bar{m}) \quad (5)$$

It was assumed in the cycle calculations that the exhaust gas at power turbine inlet and exit has the same pressure as in the turbocharger. The power output of the power turbine is calculated from the relation:

$$N_{PT} = \eta_m \cdot m_{PT} \cdot H_{PT} \quad (6)$$

where:

- η_m – mechanical efficiency of the power turbine
- H_{TM} – enthalpy drop in the power turbine.

The temperature of the exhaust gas behind the power turbine is slightly higher than that behind the turbocharger, see relevant curves in Fig. 2. The increased load of the main engine results in the increase of both the temperature of the exhaust gas in the manifold, and the mass flow rate of the exhaust gas working in the power turbine. All this, as a final result, increases the turbine power.

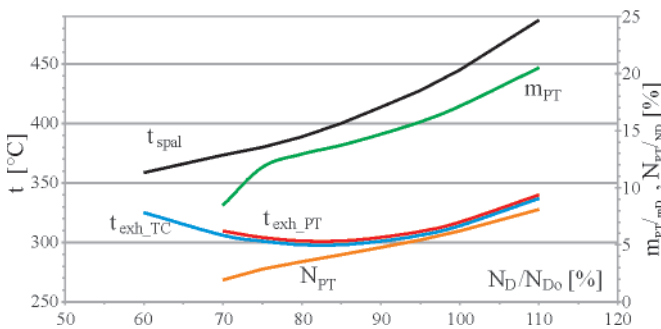

Fig. 2. Power turbine parameters vs. main engine load

Increasing the power in the main engine turbine system results in the power increase amounting to about 2% for engine

loads of an order of 70%, and to over 8% for the maximal loads, accompanied by relevant reduction of the specific fuel consumption, respectively, from 2% to about 7.5%. It is also noteworthy that for the main engine power below 60-70% the operation of the power turbine is impossible. In this case the control system should close the valve which controls the exhaust gas inflow to the power turbine, Fig. 1.

STEAM TURBINE CALCULATIONS

The assumed two-pressure waste-heat boiler is identical with that analysed [3]. Fig. 3 presents a scheme of the steam system consisting of a steam turbine and a waste-heat boiler. From the turbocharger and the power turbine the exhaust gas flows through the waste-heat boiler delivering the heat to the steam cycle. In the high-pressure cycle (p_H) the superheated steam is produced, the parameters of which are (p_o , t_o) and the mass flow rate is m_o . This steam flows to the steam turbine. The low-pressure cycle (p_L) produces the saturated steam, the part m_{pw} of which is taken to cover general ship needs, and the remaining part is delivered to the steam turbine increasing its power. The applied steam turbine is a condensation turbine which drives, as an additional drive, the ship propeller screw via a reduction gear. The assumed boiling type degasifier supplies the waste-heat boiler with water having the temperature t_{FW} . The condensate flows to the degasifier from the condenser and from the heat box, a component of the general ship needs system. Additional heat needed for increasing the water temperature to the boiling temperature in the degasifier is taken from a steam turbine extraction point. The exhaust gas leaving the waste-heat boiler has the temperature t_{exh} . The temperature of the gas in front of the boiler is calculated from the balance of the mixture of gases from the turbocharger and from the power turbine.

$$t_{inlet_B} = \frac{m_{TC} \cdot i_{exh_TC} + m_{PT} \cdot i_{exh_PT}}{m_D \cdot c_g} - 273.15 \text{ [}^\circ\text{C]} \quad (7)$$

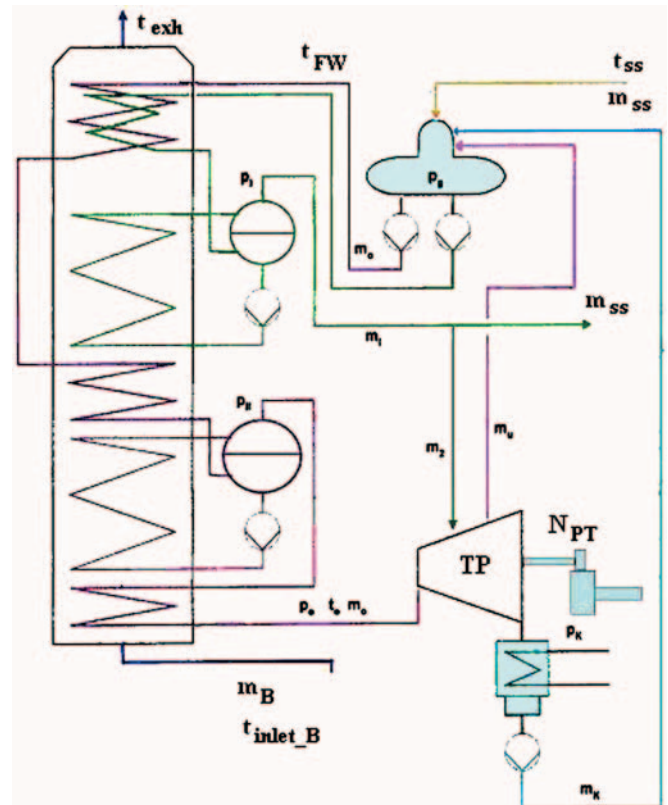

Fig. 3. Scheme of the ship system consisting of a steam turbine and a waste-heat boiler

Steam cycle optimisation

The numerical calculations of the steam cycle were performed using the algorithm presented [3]. The calculations were performed in variants for: the assumed range of the high-pressure cycle pressure (live steam pressure) $p_o \in \langle p_{o, \min}, p_{o, \max} \rangle$, the assumed range of the low-pressure cycle pressure $p_l \in \langle p_{l, \min}, p_{l, \max} \rangle$ and the assumed pressure range in the degasifier $p_g \in \langle p_{g, \min}, p_{g, \max} \rangle$.

Tab. 1 collects optimum parameters of the steam cycle for two loads of the Diesel engine. The maximum power of the steam turbine, obtained from the optimisation calculations, is $N_{ST_{\max}} = 3470$ kW for the Diesel engine load equal to 90 %. This case did not take into account the adopted limits. In a real system, certain limits are to be taken into account in the ship steam cycle. For the assumed limits the maximum power of the steam cycle is $N_{ST_{\max}} = 3075$ kW. When a steam turbine was added to the Diesel engine system, the power output of the ship propulsion system was increased by $\Delta N_{ST}/N_D = 7.37$ % and 6.64 %, respectively for the 100 and 90 % load, at simultaneous reduction of the specific fuel consumption in the combined system, respectively, from 174 g/kWh to 162.1 g/kWh and from 169.8 g/kWh to 159.2 g/kWh, see Tab. 2. The specific fuel stream was decreased by 6.86 % for 100 % load and by 6.22 % for 90 % load of the diesel engine, as compared to the fuel consumption of the diesel engine alone.

In the steam system with the limits, the heat in the diesel engine exhaust gas is used, at 90 % load for instance, for the production of the live superheated steam $m_o = 12.9$ t/h having parameters $t_o = 289$ °C and $p_o = 25$ bar, and the live wet steam $m_l = 9.30$ t/h, having temperature $t_l = 165$ °C and pressure $p_l = 7$ bar, see Tab. 1.

Tab. 1. Optimal steam cycle parameters in the combined system consisting of the Diesel engine, power turbine (parallel feeding), and steam turbine

No	N_D [%]	t_o [°C]	p_o [bar]	p_l [bar]	t_l [°C]	p_g [bar]	t_{exh} [°C]	t_{FW} [°C]	x	m_o [t/h]	m_l [t/h]	m_u [t/h]	N_{ST} [kW]	N_{ST}/N_D
without limits														
1	100	299	27.0	7.0	165	0.50	153	82	0.8715	15.02	10.78	1.93	4073	0.0791
2	90	286	20.0	5.0	152	0.50	143	82	0.8796	0.037	0.03	0.005	3470	0.0749
with limits														
1	100	299	22.0	7.0	165	2.00	163	121	0.8800	0.042	0.025	0.009	3794	0.0737
2	90	286	19.0	7.0	165	2.00	164	121	0.8812	0.038	0.022	0.008	3075	0.0664

Tab. 2. Power, efficiency and specific fuel consumption for a combined ship propulsion system with a two-stroke engine 9RTA 96C, power turbine (parallel feeding) and steam turbine

No	RTA96C engine		Diesel Engine & Power Turbine		Diesel Engine & Steam Turbine		Diesel Engine & Power Turbine & Steam Turbine		
	N_D [%]	N_D [kW]	N_{PT} [kW]	$\Delta N_{PT}/N_D$ [%]	N_{ST} [kW]	$\Delta N_{ST}/N_D$ [%]	N_{combi} [kW]	$\Delta N_{combi}/N_D$ [%]	
1	100	51480	3203	6.22	3794	7.37	58477	13.59	
2	90	46332	2211	4.77	3075	6.64	51618	11.41	
	N_D [%]	N_D [kW]	b_{ed} [g/kWh]	b_{ePT} [g/kWh]	$\Delta b_{ePT}/b_{ed}$ [%]	b_{eST} [g/kWh]	$\Delta b_{eST}/b_{ed}$ [%]	b_{ecombi} [g/kWh]	$\Delta b_{ecombi}/b_{ed}$ [%]
1	100	51480	174.0	163.8	-5.86	162.1	-6.86	153.2	-11.97
2	90	46332	169.8	162.1	-4.56	159.2	-6.22	152.4	-10.24
	N_D [%]	N_D [kW]	η_D [%]	η_{PT} [%]	$\Delta \eta_{PT}/\eta_D$ [%]	η_{ST} [%]	$\Delta \eta_{ST}/\eta_D$ [%]	η_{combi} [g/kWh]	$\Delta \eta_{combi}/\eta_D$ [%]
1	100	51480	48.46	54.90	6.22	52.04	7.37	55.05	13.59
2	90	46332	49.66	55.53	4.77	52.96	6.64	55.33	11.41

THERMODYNAMIC ANALYSIS OF THE COMBINED CYCLE

The use of the combined ship propulsion system increases its efficiency, which leads to the decrease of the specific fuel consumption and the increase of the power, without delivery of additional fuel. Tab. 2 collects powers, efficiencies, and specific fuel consumptions for the examined combined ship propulsion system.

The use of the power turbine increases the power produced by the system by 2211 kW, i.e. by 4.77 % for the 90 % main engine load, and decreases the specific fuel consumption by 4.6 %, as compared to the classical propulsion system. Introducing a steam turbine to the combined system increases its power by 11.4 % and decreases its specific fuel consumption by 10.2 %. The efficiency of the combined propulsion system increases from 50 % to 55 %.

CONCLUSIONS

- The proposed concept of a combined marine power plant consisting of a low-speed marine diesel engine with a power turbine and steam turbine utilising the heat transported with the diesel engine exhaust gas decreases the specific fuel consumption of the plant by about 10 %. Moreover, without changing nominal power of the main engine the total power of the power plant is increased by about 11% due to the use of the waste heat in the exhaust gas. Simultaneously, the specific fuel consumption decreases by 10 ÷ 12 % as compared to the standard power plant.
- For marine power plants on large merchant ships with low-speed engines of power output over 50 MW, power plants of this type seem to be competitive with a traditional power plant.

○ At power load of 100 % CMCR, the engine 9RTA96C consumes 215 t/24h, while for the combined power plant the same power is obtained by the plant at the main engine load of 90 % CMCR and fuel consumption equal to 189 t/24h. This brings the ship owner measurable gains expressed in fuel consumption reduction by 26 t/24h.

NOMENCLATURE

b_c	- specific fuel oil consumption
c_g, c_a	- specific heat of exhaust gas and air, respectively
i	- specific enthalpy
m	- mass flux of a medium
N	- power
p	- pressure
T, t	- temperature
W_u	- calorific value of fuel oil
η	- efficiency
κ_g, κ_a	- isentropic exponent of exhaust gas and air, respectively

Indices

bar	- barometric conditions
B	- boiler
combi	- combined system
D	- marine diesel engine, supercharging
f	- fuel
inlet	- inlet passage
k	- parameters in a condenser
o	- live steam, calculation point
air	- air
ss	- ship living purposes
π	- stage of: compression in a compressor, decompression in a turbine
C	- compressor
g	- exhaust gas
T	- turbine

TC	- turbocharger
PT	- power turbine
ST	- steam turbine
exh	- exhaust passage
FW	- water supplying a waste heat boiler

BIBLIOGRAPHY

1. *A new turbocharger generation*. ABB Turbo Systems Ltd. Publication No. CH-Z 2035 98E.
2. *Description of Marine GenSet- Type L28/32H*. MAN B&W Diesel A/S. November 1993.
3. Dzida M.: *On the possible increasing of efficiency of ship power plant with the system combined of pi-ston combustion engine, gas turbine and steam turbine, at the main engine - steam turbine mode of cooperation*. Polish Maritime Research No 1(59), Vol. 16, 2009
4. Kehlhofer R.: *Combined-Cycle Gas & Steam Turbine Power Plants*. The Fairmont Press, INC. USA. 1991.
5. Schrott K. H.: *The New Generation of MAN B&W Turbochargers*. MAN B&W Publication S.A. 236 5581E. 1995
6. *Sulzer RTA 96C. Engine Selection and Project Manual*. June 2001. Wärtsilä.
7. *The MC Engine. Exhaust Gas Date. Waste Heat Recovery System. Total Economy*. Publication MAN B&W. October 1985.

CONTACT WITH THE AUTHORS

Marek Dzida, Assoc. Prof.
Faculty of Ocean Engineering
and Ship Technology
Gdansk University of Technology
Narutowicza 11/12
80-233 Gdansk, POLAND
e-mail: dzida@pg.gda.pl