

Numerical calculations of behaviour of ship double-bottom structure during grounding

Karol Niklas

Gdańsk University of Technology

ABSTRACT



The idea of the CORET project consists in adding, to the existing construction, special polymer-concrete coatings intended for the increasing of ship's capability against losing structural tightness during collision or grounding. In order to correctly design the protective barriers, to perform relevant numerical simulations is necessary. The elaborating of numerical models of ship structure behaviour during collision is very complicated and requires auxiliary simulations (on submodels) to be performed. This paper is devoted to elaborating a numerical model of a fragment of ship double-bottom structure. On the basis of experimental tests it was possible to verify and calibrate the numerical model which may be used in further design work aimed at the increasing of crashworthiness of structure during collision.

Keywords: numerical simulation, grounding, collision, CORET project, LS-DYNA software

INTRODUCTION

In the frame of the EUREKA E!3614 CORET project a proposal has been given on application, to ship double-bottom structure, additional polymer-concrete protective barriers. In the case of ship's grounding, when its double bottom outer plating is torn up, such additional barrier can ensure tightness to tanks filled with fuel oil. Numerical simulations of ship grounding are carried out to design ship side structure in such a way as to be it capable of absorbing as large amount of energy as possible (at maintained tightness). The elaborating of numerical models of ship structure behaviour during collision is very complicated and requires auxiliary simulations to be performed. The most difficult task is to model a fragment of double bottom structure in the vicinity of its contact with ground. In this zone the structure undergoes large deformations, buckling, plastic flow and tearing phenomena. For this reason a submodel of the collision zone was produced to form a model of ship double bottom fragment, which would follow - in a possibly reliable way - real structure behaviour during collision. On the basis of experimental tests it is possible to verify and calibrate the numerical model for using it further in a larger ship structure model. The below presented simulation of indenting a sphere into a fragment of ship bottom structure, being the most difficult task, is thought to aid - after making a physical experiment to verify and calibrate it - the elaborating of the model of ship double bottom structure fragment during ship grounding. In the future the model may be also used to perform calculations for designing a ship double bottom structure of an increased capability against losing its tightness during ship grunding or collision.

FEM NUMERICAL MODEL

The indenting of the sphere into a ship structure fragment by means of a hydraulic ram was simulated with the use of a numerical model. The FEM model geometry and real structure model is presented in Fig. 1. The model's analysis was made by using the explicite solver of LS-DYNA (v9.71) software. The quasi-static simulation conditions were assumed with a view of relevant conditions for the model calibration experiment. To accelerate the calculations the sphere velocity equal to 0.8 m/s was assumed. The diameter of the sphere was equal to 0.3 m, and it was modeled as a solid body.

The boundary conditions adequate to fixing the model during the experimental tests, were assumed (Fig. 2). Though the small velocity value allows for neglecting the dynamic aspects, it makes time of the calculations much longer.

Duration time of the simulation, assumed equal to 5s, and the maximum time step possible to be applied, made it necessary to introduce mass scaling in order to shorten time of calculations. The model consisted of 18.000 shell elements. To lower the total number of elements by making the FE grid more dense in the regions of the greatest expected stresses, is rather not effective in the calculations which take into account large non-linearities. Apart from an unknown influence of the more dense grid on calculation results and necessity of its checking, the effect of lowering the total number of elements would be reduced by a shorter time step. As the time step is selected for the smallest element of the model hence the grid concentration would be rather not effective in the case in question.



Fig. 1. Numerical model and real structure model of a fragment of ship double bottom structure

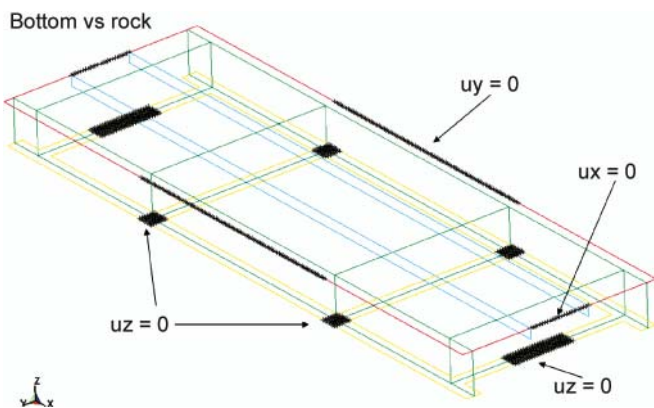

Fig. 2. Boundary conditions assumed for the numerical model

To apply greater elements to the whole model is also not possible because of the reasons given below. Very large deformations expected during the simulation (up to complete tear-up of the plating) allow for using only a certain number of FEs per span of structural element. In the structure in question the small-depth stiffener (flat bar) is that which determines the smallest dimension. For correct modeling the strictly elastic deformations one FE per span of the stiffener is sufficient. For correct taking into account the buckling and ultimate strength phenomena four FEs per stiffener span are necessary.

If the modeling of large plastic deformations is required, especially those around „plastic hinge”, the minimum number of FEs will amount to 16.

The elaborated model satisfies all the above mentioned conditions resulting from numerical aspects.

The next aspect of building the numerical model is to select an appropriate FE.

The LS-DYNA software contains a rich data base of shell FEs. The usually assumed shell element is that of Belytschko-Tsay type (BT), based on ideally flat geometry, which is

very effective during calculations. Until cracks and very large deformations are not involved the BTElement correctly represents the behaviour of thin-walled steel structures during collision [1, 2]. However the necessity of taking into account very large deformations and plate tearing-up, induces to select more sophisticated FEs, namely: the Belytschko-Wong-Chiang FE and 16 FE (fully integrated shell). For the model, influence of FE selection on calculation results should be also analyzed. The successive aspect is to select a form of shell FE (triangular or quadrilateral), arrangement of FEs (uniformly arranged or not), as well as a number of integration points. As regards numerical errors a better solution is to select obviously a quadrilateral FE, however predefined lines of nodes constitute the main drawback of a regular grid composed of quadrilateral FEs, which often make real crack directions during plate tearing-up false [3]. Simultaneously, the using of triangular FEs, even to control numerical errors, is rather unfavourable. The influence of the grid on calculation results, especially in the case of highly non-linear calculations, may be very large [1]. It seems reasonable to investigate influence of using various grids in the most interesting zones of structure. The phenomenon of contact is a successive non-linearity taken into account in the model in question. In the analysis, automatic algorithms of contact to monitor distances of particular nodes during each time step, are applied. The static friction coefficient equal to 0.74 and dynamic one equal to 0.57 (steel-to-steel) was assumed.

The model of elastic-plastic material behaviour following the stress-strain relationship (based on tensile test) and having strain-dependent plasticity limit (acc. Cooper-Simonds model), was assumed. The material failure phenomenon was taken as the strain (elongation) criterion. When strain in any element exceeds its limit value the element is automatically excluded from the model and the calculations based on the eroded grid, are continued. The influence of critical strain (elongation) on calculation results was analyzed in the work [4]. The limit strain of FE is defined in function of FE's size. The critical strain value of the best fit can be determined by simulating the tensile test of a sample and calibrating the model with the use of real sample test results.

RESULTS

The energy equation shown in Fig. 3, is calculated for each time step. The energy is composed of elastic strain energy and work done for plastic deformation. And, the external work contains work done by applied forces, pressures, as well as that done by elements of the applied boundary conditions

$$E_{kin} + E_{int} + E_{si} + E_{rw} + E_{damp} + E_{hg} = E_{kin}^0 + E_{int}^0 + W_{ext}$$

Total Energy E_{total}

where:

- E_{kin} – kinetic energy
- E_{int} – internal energy
- E_{si} – sliding energy
- E_{rw} – rigidwall energy
- E_{damp} – damping energy
- E_{hg} – hourglassing energy
- E_{kin}^0 – kinetic energy ($t = 0$)
- E_{int}^0 – internal energy ($t = 0$)
- W_{ext} – external work

Fig. 3. Energy equation

(displacements, velocities and accelerations). In Fig. 4 the particular total energy components are presented. As it can be observed, internal energy is of the greatest share. The energy increases until the limit strain values assumed for plating elements are not exceeded, and after plate tearing-up it maintains almost constant value. Friction energy a little only contributes in the total energy and its influence grows after plate tear-up. Percentage share of the kinetic energy resulting from possible increase of the sphere's velocity in order to reduce time of calculations, would be negligible, hence quasi-static conditions have been maintained. The maximum value of the reaction force at supports along z- axis (Fig. 5) is equal to 1.15 MN.

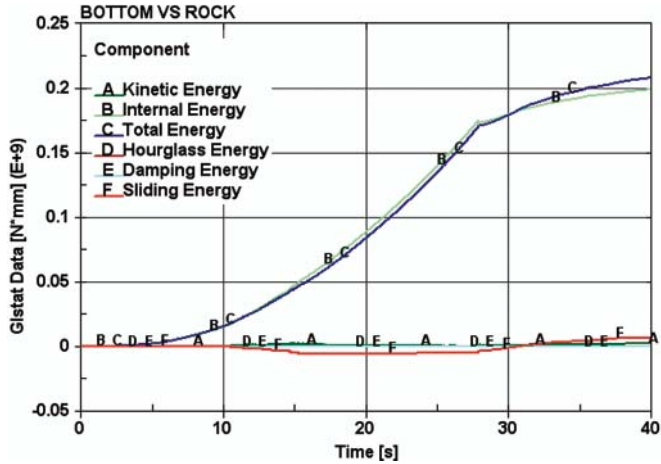

Fig. 4. Total energy and its components

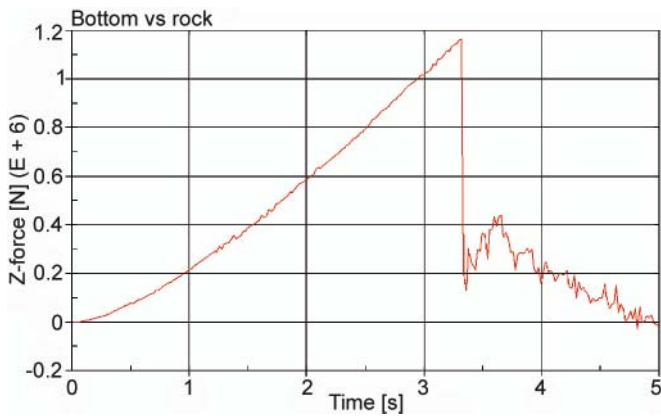

Fig. 5. Total reaction force at supports along z - axis.

Fig. 6 presents the reduced (Mises) stresses in successive time instants during simulation. The tear-up of plating takes

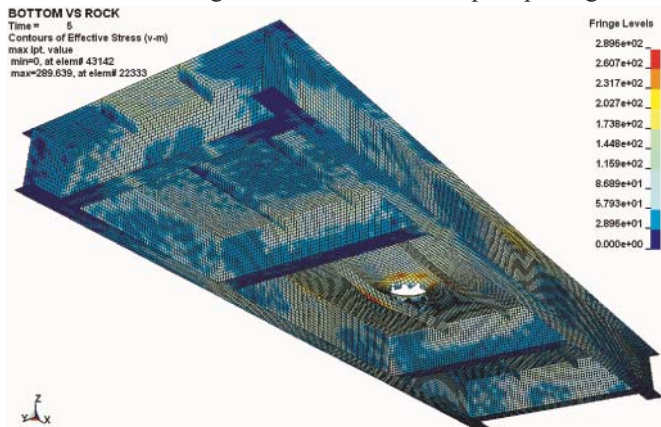

Fig. 7. Image of reduced (Mises) stresses (t=5s)

place after 3.3s and covering the distance of 266 mm. Fig. 7 shows the stress image after stopping the simulation. In the instant $t=3.3$ s the deformations of particular elements of the model are as follows: large-depth stiffeners - 15.8 mm (Fig. 8); small-depth stiffeners - 129.4mm (Fig. 9); side plating - 262.9 mm (Fig. 10).

Structural failures caused by indenting the sphere into side plating are of a local character.

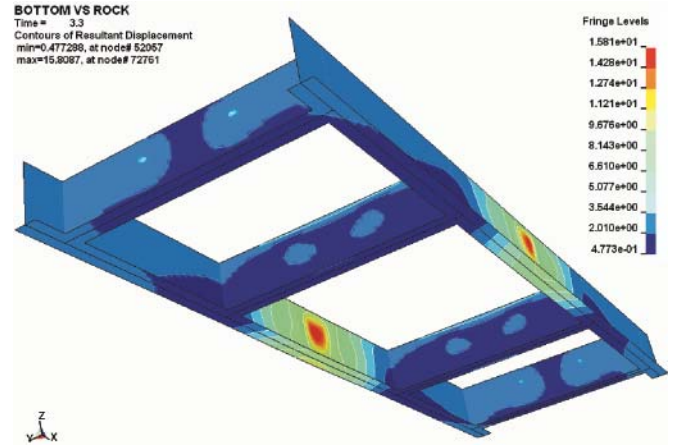

Fig. 8. Deformations of large-depth stiffeners

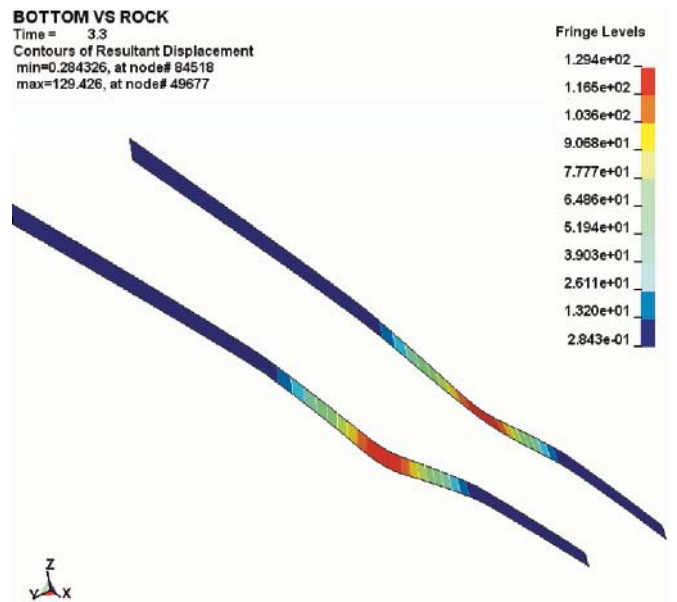

Fig. 9. Deformations of small-depth stiffeners

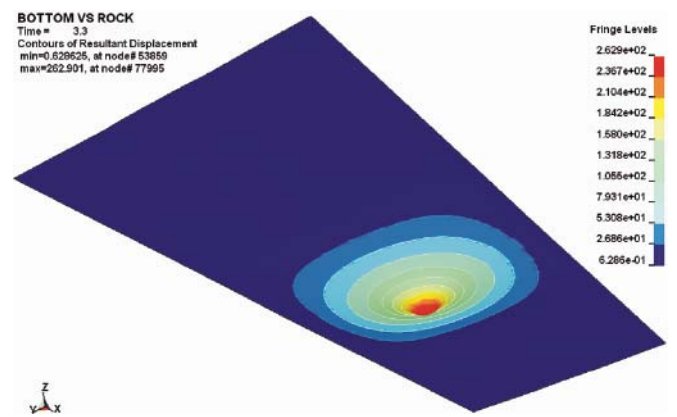

Fig. 10. Deformations of side plating

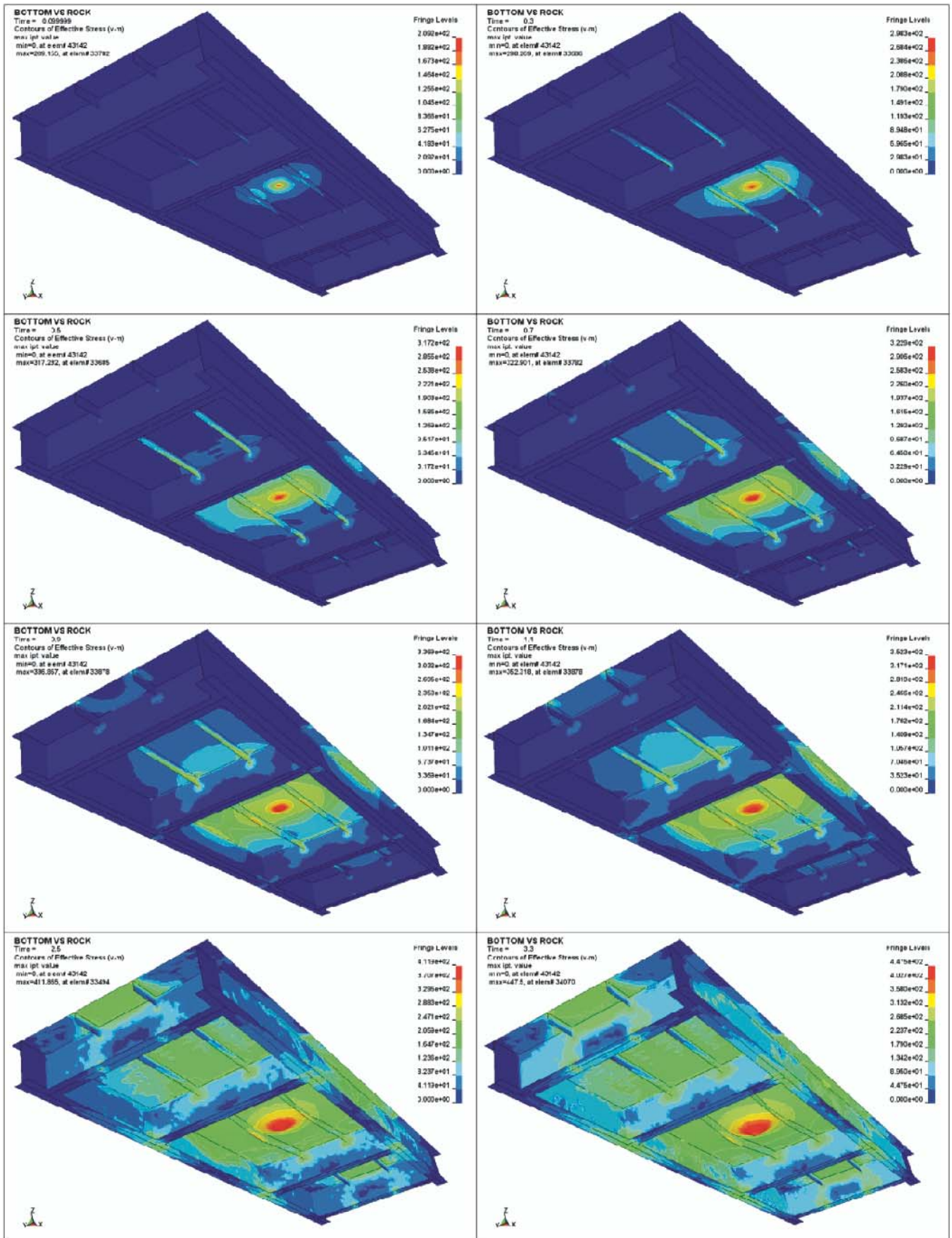

Fig. 6. Reduced (Mises) stresses in successive time instants (down from top, row by row: $t = 0.1, 0.3, 0.5, 0.7, 0.9, 1.1, 2.5, 3.3s$)

SUMMARY

Ship traffic statistics of the last years as well as predictions for the coming ten years leave no doubts that risk of ship collision and grounding is still a very serious problem.

Many research projects on safety improvement have been carried out by many scientific centres worldwide, e.g. [5-10]. Some problems have been solved so far. Most attention has been focused on the increasing of structural capability of tankers against losing tightness resulting from collision or grounding. Until 2015 all single-skin tankers have to be withdrawn from service. Simultaneously, size of new tankers of various types has so increased that the amount of fuel oil carried out onboard for their propulsion has become comparable to cargo capacity of a small tanker. Single-skin fuel oil tanks are often located in ship's double bottom. In the case of ship's grounding danger of ecological disaster resulting from outer plating tear-up is similar to that in the case of a single-skin tanker. Therefore the attempt at decreasing the risk of loss of tank tightness in the case of collision, by applying, to the typical ship structure, additional polymer-concrete coatings, has been undertaken. To this end, the numerical simulations of collision were used. However auxiliary simulations on submodels were necessary to make the numerical model fully adequate to real conditions. Such submodels usually cover structural fragments most difficult for modeling, and their verification and calibration is done in an experimental way. This work has been aimed at the elaboration of the double-bottom structure fitted with additional polymer-concrete layers, capable of preventing fuel oil leakage in the case of collision.

BIBLIOGRAPHY

1. Simonsen B. C., Lauridsen L. P.: *Energy absorption and ductile failure in metal sheets under lateral indentation by a sphere*. Int. J. Impact Eng. England, 2000
2. Tornqvist R.: *Numerical prediction of ultimate strength of steel structures*. Department of Naval Architecture and Offshore Engineering, England, 2000
3. Wu F., Spong R., Wang G.: *Using numerical simulation to analyze ship collision*. International Conference on Collision and Grounding of Ships 2004, Japan
4. Zhang A., Suzuki K.: *Numerical simulation the bottom structure grounding test by LS-DYNA*. 5th European LS-DYNA Users Conference, Convention Centre in Birmingham, United Kingdom, May 2005
5. HELCOM: *Maritime Transport in the Baltic Sea. Draft HELCOM Thematic Assessment in 2006*. Stakeholder Conference on the Baltic Sea Action Plan, Helsinki, Finland, 07.03.2006
6. Germanischer Lloyd: *Rules for Classification and Construction: Ship Technology, Part-1 Seagoing Ships, Chapter 1 Hull Structures, Section 33 Strengthening against Collisions*. Hamburg, Germany, 1992
7. Alsos H.S., Amdahl J.: *Intentional grounding of disabled ships*. Marine 2005 Conference on Computational Methods in Marine Engineering, Oslo, Norway, 27-29 June 2005
8. Hu Z., Gu Y., Gao Z.: *Research on crashworthiness of Y-shape side structure design for FPSO*. International Offshore and Polar Engineering Conference (ISOPE), Seoul, South Korea, June 2005
9. Brown A.J.: *Modelling Structural Damage in Ship Collisions*. SSC-422, Ship
10. Sajdak, J., Brown, A.J.: (2005). *Modeling longitudinal damage in ship collisions*, Report SSC-437/SR-1426, Ship Structure Committee 2004

