

A method for evaluating durability of porous slide bearings

Piotr Bzura, Ph. D.
Gdansk University of Technology

ABSTRACT



The article presents the structures of porous slide bearing bushes and greasy lubricants, and the similarity criterion resulting from these structures. A physical model is proposed which describes the operation of the porous slide bearing bush taking into account, via analogy, the phenomena taking place in the greasy lubricant nodes instead of those observed in the bush structures.

Included are the results of experimental tests of three greasy lubricants which allow transferring the results recorded in model experiments to real objects.

Key words: structure; durability; strength of bonds

INTRODUCTION

The published data on operating parameters of Diesel engines used in shipbuilding reveal a remarkably slowing increase, or even decrease, of the consumption of lubricating media [17, 18]. This effect results, on the one hand, from ship owners' permanent search for the ways to reduce the cost of operation of the internal combustion engines, and, on the other hand, from increasing pressure toward the reduction of environment pollution caused by those engines [5]. The rationalisation of the use of lubricating media requires delivering them to tribological nodes in optimal volumes and precisely defined time intervals [11, 12].

This need for rationalisation of lubrication is the reason why slide bearings with "limited supervision" are expected to be used in future in marine piston engines. To this group belong, for instance, the bearings with porous bushes. A distinguishing feature of these bearings is their durability, which can be evaluated in laboratory tests using the here presented method.

DURABILITY OF POROUS SLIDE BEARINGS

The porous slide bearings belong to the group of bearings which do not need lubricating service, and therefore they are frequently called the slide bearings with "limited supervision". The lubricant is not delivered to them from outside, but it is

collected in bush wormholes and is to be periodically refilled. Taking into account the lubricating supervision, a distinction should be made between the porous slide bearings and those with conventional lubrication - Fig. 1 [11, 12].

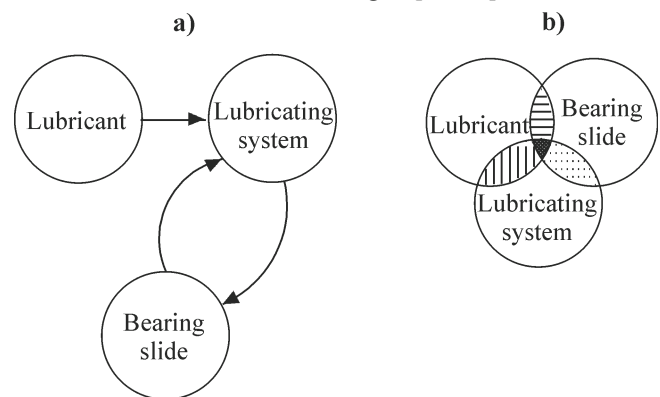

Fig. 1. Scheme illustrating the classification of slide bearings due to lubricating supervision: **a)** slide bearings with conventional lubrication, **b)** porous slide bearings (the lubricating system and the lubricant are within the journal-bush area)

The bushes in the porous slide bearings (Fig. 2) resemble a sponge, due to the presence of wormholes having the form of capillary ducts [4]. After saturating the porous bush with the lubricant using the vacuum method and connecting it with the journal, the self-lubricating porous slide bearing is ready for operation [9, 11, 12]

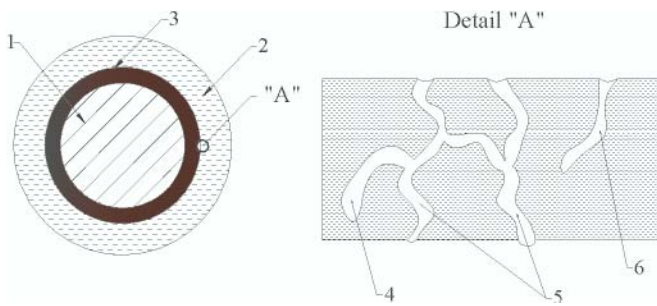

Fig. 2. Scheme of porous slide bearings : 1) journal, 2) bush, 3) lubricant placed in the bush material, 4) dead end, 5) capillary ducts open at two ends, 6) capillary duct open at one end

The self-lubricity of the porous bearings [3,10,11,12,14,15] is realised using the oil flow from the porous wall, which is mainly forced by the difference in thermal expansion of the lubricating oil and the metal bush structure (Fig. 3). Initially, when the bearing is cold, some role is also played by elastic strains of the bush material which, pressed by the journal, releases the oil from the wormholes (per analogy to a sponge). Then the journal moving at the presence of the oil generates the hydrodynamic pressure in the oil clearance. In the high pressure area the oil is pressed back into the porous wall, then it flows through the wormholes and flows out to the oil clearance at the low pressure area.

During the operation, the porous slide bearings lose their durability, following the decrease of their lubricating ability. All this is caused by oil evaporation and leakage off the bearing, due to excessively high temperatures of bearing operation and the ageing of the oil. Therefore the area of application of the porous slide bearing is limited by its load capacity, i.e. the journal load, at which the porous slide bearing can still work safely which is affected by [12]:

- the reduced amount of oil and rate of its circulation,
- the decreased hydrodynamic uplift pressure.

Experimental tests are in progress now which are oriented on evaluating permissible journal loads in porous slide bearings for given sliding speeds at which the slide bearing can still work safely [9, 11, 12, 14]. Unfortunately, in these tests different criteria of load limits for given speeds are adopted, which reduces the space for data comparison and reliability.

In this context, to provide opportunities for comparing journal load limits in different porous slide bearings, a simple physical model is proposed in the form of a four-sphere apparatus T-02. The frictional association in this machine is created using four spheres, each of 12.7 mm in diameter, made of ŁH15 steel in the accuracy class 16 according to the PN-83/M-86452 standard. Three spheres are placed in the lower holder-container having the form of a small cup, which is poured with the greasy lubricant. The fourth sphere, which

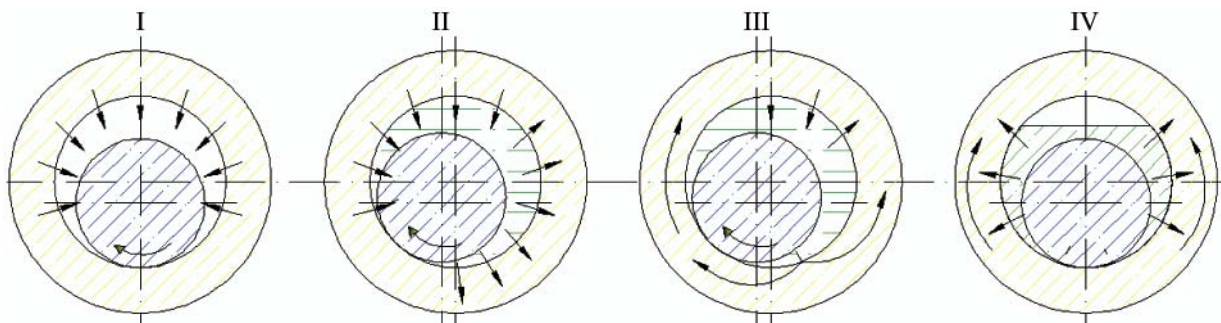

Fig. 3. Scheme of porous bearing lubrication: I) start-up, II) thermal outflow, III) equilibrium, IV) standstill [12]

models the journal in the porous slide bearing, is fixed in the upper holder. The spheres in the cup are pressed towards the sphere fixed in the upper holder using a special lever. The parameters controlled during the tests include the journal load and rotational speed, and the greasy lubricant temperature [19] – Fig. 4.

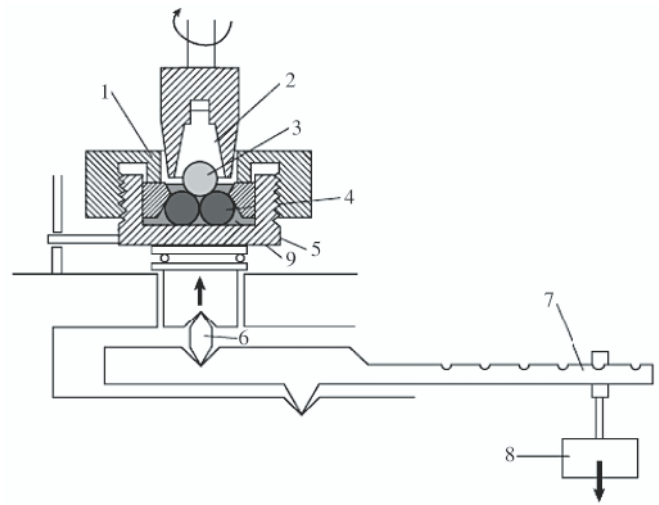

Fig. 4. Kinetic scheme of the four-sphere apparatus: 1) cover which fixes the lower spheres, 2) holder of upper sphere, 3) upper sphere (rotating), 4) lower spheres (stationary), 5) container with the tested lubricant, 6) prism, 7) lever, 8) weights, 9) tested greasy lubricant [19]

DURABILITY OF GREASY LUBRICANTS

The greasy lubricants [16] are semi-liquid plastic lubricants having the colloidal structure which consist of the base oil (the mineral oil in general, but in exceptional cases also the synthetic oil) and the thickening agent. They are used wherever frequent lubricating oil refilling is extremely difficult or impossible. They execute all functions of liquid lubricants – except cooling and cleaning of friction surfaces. Like for the porous bearing bushes, which are the systems consisting of a metal skeleton filled with the lubricating substance, the structure of the greasy lubricants (composed of the base oil and the thickener, Fig. 5) resembles the sponge, and this fact was assumed as the required similarity criterion for creating the physical model.

In the greasy lubricant the percent share of the thickener is low, unlike the porous bushes in which the bush skeleton plays the role of “the thickener”. Frequently, to strengthen the structure of the lubricant and make it more resistant to the action of external agents, extra additives are used [16] which modify the cohesion forces between the base oil and the thickener in the required range. The bigger the cohesion forces, the more coherent is the body and the more difficult is to stratify it. Therefore the strength of the bonds can be considered the property determining durability of the greasy lubricants.

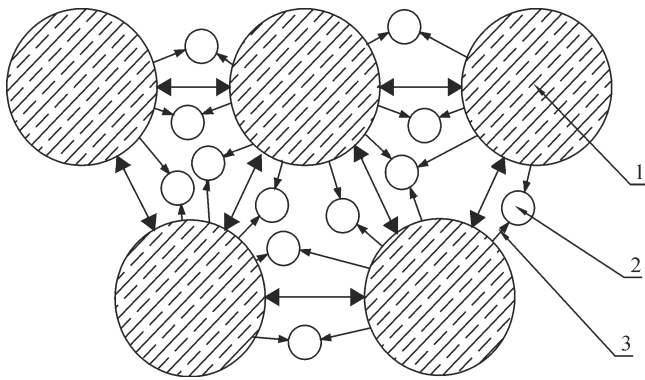

Fig. 5. Scheme of the structure of greasy lubricants: 1) thickener; 2) base oil, 3) cohesion forces

The parameter which determines the durability of a conventional slide bearing (Fig. 1a) is the lubricating ability of the oil, i.e. the property of the lubricating substance which characterises its ability to preserve lubricating features in mitigated solid friction conditions. This way it determines oil ability to create a stable boundary layer being the consequence of the adsorption of fluid particles on the solid body surfaces. The measure of the lubricating ability of the oils is the durability of the boundary layer, i.e. the durability of bonds between the lubricating substance (adsorbent) and the base [1, 2, 6, 8, 16].

In this context it seems logical to relate the durability of the bonds with the lubricating ability of the greasy lubricants, which defines the minimal pressure required for stopping the action of the cohesion forces between the thickener and the base oil. Therefore the lubricating ability of the greasy lubricants can be considered a parameter determining the durability of the slide bearing with "limited supervision" (Fig. 1b).

PHYSICAL MODEL OF A POROUS SLIDE BEARING

The structure of the porous bearing bush is characterised by the set of technical and operating characteristics assumed when designing and manufacturing the bearing. These characteristics determine the level of bearing applicability to realise assumed tasks in given operating conditions. Each structure has a separate set of structure parameters which map the technical condition.

$$U = \{u_i\} \text{ for } i = 1, \dots, n \quad (1)$$

Change in the technical condition of the porous slide bearing is, among other factors, a function of the resistance of the porous bush saturated with the lubricant to ageing. During bearing operation, the effects of excitation forces acting in the micro- and macro- environment of the bush cumulate with time, which leads to the leakage flow of the lubricant, and bearing seizure as a possible further consequence. Therefore an important parameter which determines the durability of the porous slide bearing is structural strength of the bushes saturated with the lubricant.

The durability of the greasy lubricant is, in turn, the feature which determines the strength H of the bonds between the thickener and the base oil (Fig. 5). Consequently, the strength of bonds of the greasy lubricant can be identified with the structural strength of the porous slide bearing bush.

The strength of bonds of the greasy lubricant can be evaluated by analysing the diagram of the friction torque (Fig. 6) as the time function, created using the results of the investigations of the physical model which was the friction pair of the apparatus T-02 (Fig. 4) immersed in the greasy lubricant.

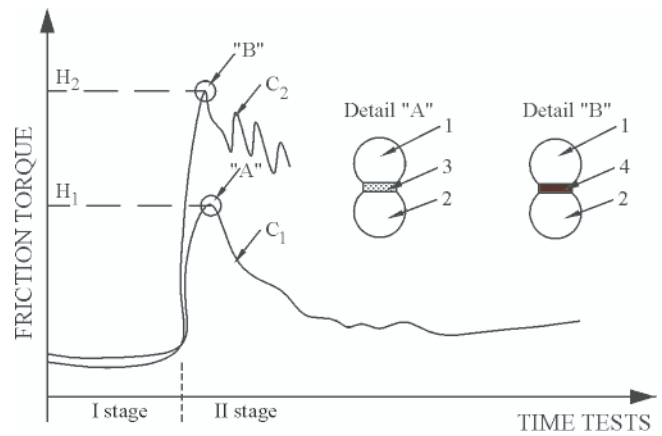

Fig. 6. Diagram of greasy lubricant friction torque: C_1) curve which characterises the greasy lubricant revealing small strength of bonds H_1 , C_2) curve which characterises the greasy lubricant revealing large strength of bonds H_2 , A) time when the boundary layer is broken and reconstructed, B) time when the boundary layer is broken and not reconstructed, 1) upper sphere of the friction pair, 2) lower sphere of the friction pair, 3) greasy lubricant base oil, 4) friction pair seizures

The shapes of curves C_1 and C_2 depend on the type of the greasy lubricant. It results from their nature that the limit of strength of bonds between the thickener and the base oil is preserved as long as the lubricant resistance to breaking is larger or equal to the destroying actions (stage I). Once the bonds are broken, the leakage of the base oil takes place. If the base oil reveals high lubricating ability, characteristic for lubricants [1, 2] and, simultaneously, it has low strength of bonds of the greasy lubricant H_1 (symbol A in Fig. 6), all this produces stable bonds between the base oil and the foundation. In the opposite case, when the base oil reveals low lubricating ability concerning the lubricating oil and, at the same time, high strength of bonds of the greasy lubricant H_2 (symbol B in Fig. 6) the boundary layer will not appear and the seizure of the bearing will take place.

That is why the porous slide bearings for which the physical model is the friction pair in which the seizure is observed (curve C_2), are characterised by larger maximal load which they can carry.

EXPERIMENTAL TESTS

The measurements were performed on the friction pair of the T-02 apparatus with spheres immersed in a greasy lubricant (Fig. 4). The following lubricants were tested:

- the graphite grease created on the base of the mineral oil with 10% of natural graphite, the minimum, thickened with the lime and used for lubricating heavily loaded friction pairs in temperatures ranging between -20 and $+50^\circ\text{C}$;
- the LT43 grease created on the basis of the mineral oil thickened with lithium. It contains refining additives, especially those acting towards anticorrosion, anti-oxidation and improvement of lubricating abilities. It is used for lubricating heavily loaded friction pairs in temperatures ranging between -20 ÷ $+130^\circ\text{C}$;
- the grease being a composition of the graphite grease and the LT43 grease.

Due to the flow limits of the greasy lubricants, all tests were performed at the temperature of 100°C . Two test procedures were executed:

- determining the strength of bonds H [Nm] at continuous load increase for the rotational speed of the spindle equal to 500 rev/min,

- determining the strength of the structure H [Nm] at continuous load increase for the rotational speed of the spindle equal to 1440 rev/min.

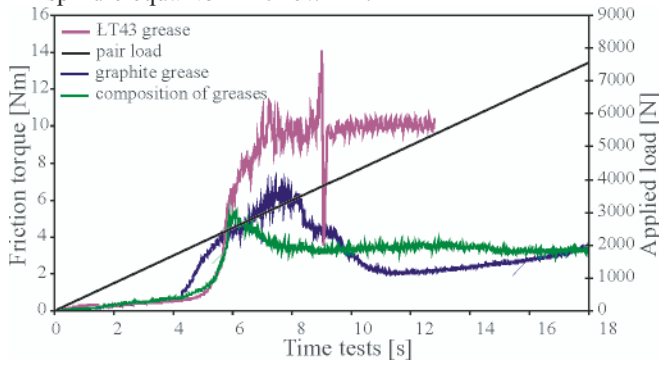

Fig. 7. Joint diagram of greasy lubricants for spindle rotational speed $n = 500$ rev/min

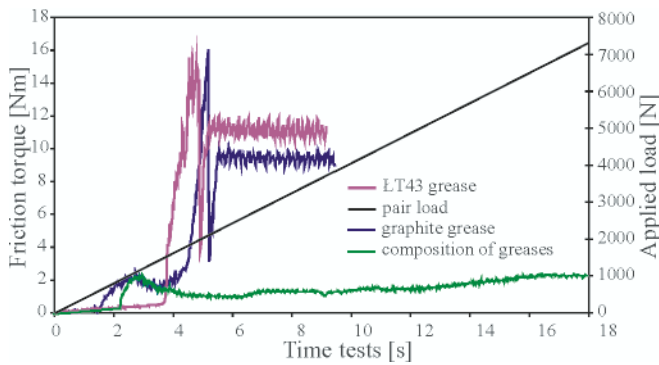

Fig. 8. Joint diagram of greasy lubricants for spindle rotational speed $n = 1440$ rev/min.

The obtained values show that:

- the smaller the rotational speed of the journal, the larger the load P[N] needed for breaking the boundary layer created on the spheres,
- the graphite grease with the thickener having calcium compounds reveals very small strength of bonds, and the boundary layer between the spheres and the greasy lubricant in the friction pair was broken at low seizing load;
- the LT43 grease with the thickener having lithium compounds reveals high strength of bonds and breaking the boundary layer took place at higher value of seizing load.
- the composition of greases consisting in 50% of the graphite grease and 50% of the LT43 grease reveals the strength of bonds comparable with the graphite grease.

When the boundary layer is broken, the thickener and the base oil separate from each other (points A and B in Fig.6) which provides opportunities for evaluating the strength H of

bonds of the greasy lubricants. This value of H can be identified with the structural strength of the bushes saturated with the lubricating oil, considered the basic parameter of the durability of porous slide bearings.

POSSIBILITY OF TRANSFER OF THE MEASURED RESULTS TO A REAL OBJECT

The rate of the conversion of the porous slide bearing from the state of operating ability to partial ability, or disability, can be presented using the Weibull, normal, or another distribution. Therefore transferring the experimental data from the physical model to a real object is possible, for instance by creating the interval of porous slide bearing technical efficiency tolerance [8] depending on the bush structure parameter which determines the durability of porous slide bearings. This can be done in the following steps:

- measuring the strength of bonds of the greasy lubricant having the characteristics correlated (via acoustic emission, for instance [7]) with the strength of the porous bearing bush structure with respect to the operating time τ_1 (the values will be within the interval $u' - u''$ and their distribution will be close to normal – Fig. 9);

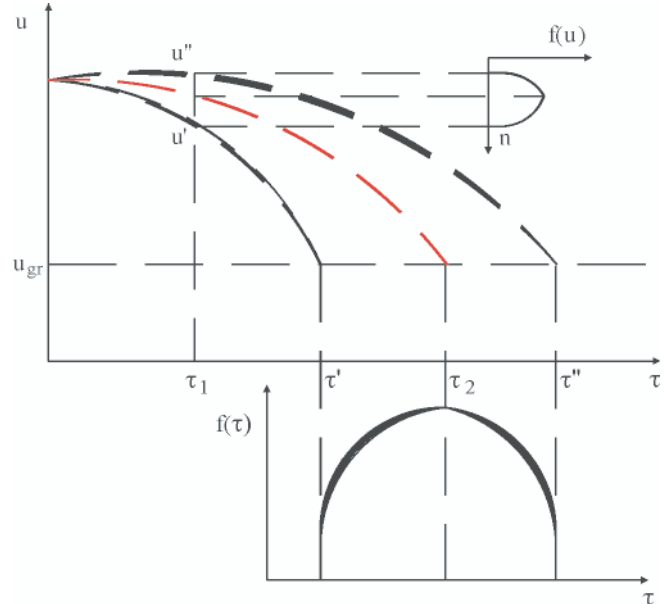

Fig. 9. Interval of porous slide bearing technical efficiency tolerance: τ – time of porous slide bearing operation, u – strength of porous slide bearing bush structure, u_{gr} – bush structure strength limit, $f(u)$ – probability density of the random variable u , $f(\tau)$ – probability density of the random variable τ

- determining the time period of full operating ability of the porous slide bearings until time τ_2 with the tolerance ranging

Table 1. Evaluated values of diagnostic parameters

| | Results of measurements for $n = 500$ rev/min | | |
|--|---|------------------------------|-------------------------|
| | Seizing load P[N] | Seizing load limit P_z [N] | Strength of bonds H[Nm] |
| Graphite grease | 1656 | 7400 | 6.7 |
| Grease LT43 | 2229.6 | 3943.2 | 11.21 |
| Composition of greases | 1924.8 | 7400 | 5.37 |
| Results of measurements for $n = 1440$ rev/min | | | |
| | Seizing load P[N] | Seizing load limit P_z [N] | Strength of bonds H[Nm] |
| Graphite grease | 700.8 | 2389.2 | 2.34 |
| Grease LT43 | 1461.6 | 1984.8 | 15.61 |
| Composition of greases | 820.8 | 7400 | 2.29 |

within $\tau' - \tau''$ for the known limit of the strength of bonds of the greasy lubricant (the value taken from experimental investigations) - Fig. 9.

FINAL REMARKS AND CONCLUSIONS

- Although the physical model of a porous slide bearing, presented in the article as the friction pair of the apparatus T-02, cannot be treated as fully adequate to real porous slide bearings, the obtained results of the tests indicate that the application of the here presented method for examining the strength of the porous bush structure is fully justified.
- The presented theoretical and experimental analysis of the physical model shows that the strength of bonds of the greasy lubricants, i.e. their lubricating ability can be considered one of parameters of porous bearing bush structure. The analysis of lubricating ability of the greasy lubricants determines the area of applications of the porous slide bearings with respect to their lubricating ability, i.e. durability.

BIBLIOGRAPHY

1. Bzura P.: *Method of identification of the slide tribological system top laser condition by ASSESSMENT of the T-02 four-ball tester friction NODE operation*, Journal of KONES Powertrain and Transport, Vol.16, No.3, p.69-76, Warszawa 2009.
2. Bzura P.: *The effect of lubricating ability on the operation of the tribological system*, (in Polish), Zeszyty Naukowe Akademii Marynarki Wojennej, 178A / editor: Cz. Dyrzc - Instytut Konstrukcji i Eksploatacji Okrętów AMW. - Gdynia: Wydaw. AWM. – 2009.
3. Cameron A.: *The principles of lubrication*. New York McHill 1987.
4. Cegielski W., Rutkowski W.: *Sintered bearings* (in Polish). Warsaw, PWT, 1960.
5. Girtler J.: *Statistic and probabilistic measures of diagnosis likelihood on the state of self-ignition combustion engines*, Journal of POLISH CIMAC Diagnosis, Reliability and Safety, Vol.2, No. 2, Gdańsk 2007, p.57-63.
6. Girtler J.: *Stochastic Model Of The Process Of Starting Combustion Engines And Practical Application Of The Process*, Journal of POLISH CIMAC Diagnosis, Reliability and Safety, Vol.3, No. 2, Gdańsk 2008, p.47-54.
7. Girtler J., Darski W., Olszewski A., Baran I., Nowak M.: *The use of acoustic emission to identification damages bearings the main and crank engines about the automatic ignition*, Journal of POLISH CIMAC Diagnosis, Reliability and Safety, Vol.4, No. 2, Gdańsk 2009, p.57-70.
8. Hebda M., Mazur T., Pelc H.: *Theory of operation of vehicles*, (in Polish), Wydawnictwo komunikacji i łączności Warsaw 1978.
9. GLACIER INDUSTRIAL BEARINGS Catalogues, UK.
10. Krzeziński K.: *Pressure distributions and load capacity of the hydrodynamic lubricating film in porous bearings*, (in Polish), Theoretical and Applied Mechanics 2/1978, s. 169–180.
11. Lawrowski Z.: *Technique of lubrication*, (in Polish), Wydawnictwo Naukowe PWN Warsaw 1996.
12. Lawrowski Z.: *Maintenance-free slide bearings*, (in Polish), Wydawnictwo Politechniki Wrocławskiej, Wrocław 2001.
13. Meurisse M.H., Guidicelli B.: *3D conservative model for self-lubrication porous journal bearings in hydrodynamic study-state*. Journal of Tribology. Tran. of the ASME, Vol. 121/3, 1999, s. 529–537.
14. Nepale M.J.: *Tribology handbook*, Butterworths, Londyn 1973.
15. Nield D.A., Bejan A.: *Convection in Porous Media*. Springer-Verlag, New York, Berlin, Heidelberg 1999.
16. Industrial lubricants. Manual, (in Polish), Wydawnictwo TOTAL Polska Sp.z o.o., Warsaw 2003.
17. Project Guides, MAN Diesel&TURBO.
18. Ship Power Product Catalogue, Wärtsilä.
19. Szczerek M., Tuszyński W.: *Tribological tests. Seizing*. Radom: Biblioteka Problemów Eksploatacyjnych 2000.

CONTACT WITH THE AUTHOR

Piotr Bzura, Ph. D.
Faculty of Ocean Engineering
and Ship Technology
Gdansk University of Technology
Narutowicza 11/12
80-233 Gdansk, POLAND
e-mail: pbzura@pg.gda.pl