

Graphical interpretation of the power of energy losses and power developed in the hydrostatic drive and control system elements

Grzegorz Skorek, Ph.D.
Gdynia Maritime University, Poland

ABSTRACT



This publication presents, analyses and compares the areas of the power fields of energy losses occurring in the elements of two hydraulic systems with different structures of the hydraulic linear motor speed control.

Keywords: hydraulic motor; energy balance; energy losses; energy efficiency; capacity pump; hydraulic servo mechanism; hydrostatic drive system

INTRODUCTION

The paper presents graphical interpretation of the power of energy losses and power developed in the elements of two different systems with the throttling series control of the hydraulic linear motor speed. The analysis was carried out by comparing, at selected hydraulic linear motor operating parameters, the areas of the power fields of energy losses occurring in the elements of those structures.

The investigations involved two systems with proportional directional valve, fed by a constant capacity pump (Fig. 1):

- with the use of an overflow valve - a constant pressure structure,
- with the use of a hydraulic cylinder supply conduit pressure controlled overflow valve - a variable pressure structure.

The investigated structures operated at the same hydraulic linear motor operating parameters, i.e. its load F_M and speed v_M .

The analysis allows to compare the values of power ΔP of losses ensuing from the used structure of control of the hydraulic linear motor speed as well as the value of power P_{pc} absorbed (consumed) by the pump from its driving electric motor, power necessary for providing the required stable value of useful power $P_{Mu} = F_M v_M$ of the hydraulic linear motor driven by the pump.

Graphical presentation, by fields of specified areas, of the power of energy losses in the hydrostatic drive and control system elements as well as power developed in the hydraulic displacement machines used in the system, becomes a tool facilitating comparing the values of particular losses [1].

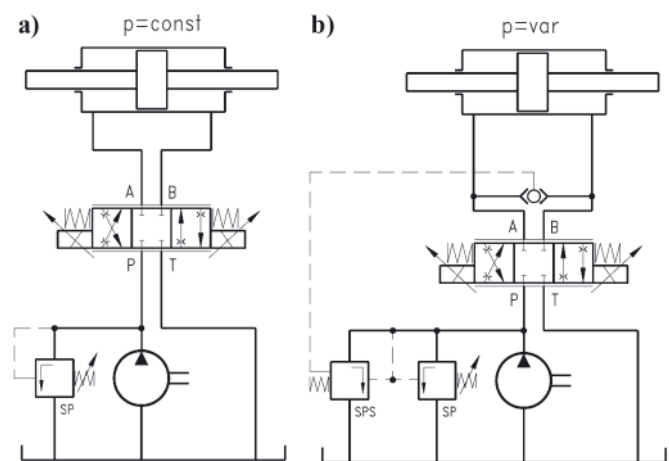

Fig. 1. System with proportional directional valve fed by a constant capacity pump [3]: **a)** with the use of an overflow valve – $p = \text{const}$ structure, **b)** with the use of a hydraulic cylinder supply conduit pressure controlled overflow valve – $p = \text{var}$ structure

Presentation of the fields of power of energy losses allows to make conclusions regarding e.g. elimination of the power of structural volumetric and pressure losses in the motor speed throttling control elements, in the proportional control systems and in the hydraulic servo-mechanism systems. Graphical interpretation by the field areas of the power of energy losses in the hydrostatic drive system elements and of the power developed by the system elements allows to compare those losses and powers with the area of the reference power field defined by the product $Q_{pt} p_n$ of the theoretical pump capacity and the system nominal pressure [1].

HYDRAULIC SYSTEM WITH PROPORTIONAL CONTROL OF THE CYLINDER FED BY A CONSTANT CAPACITY PUMP IN THE CONSTANT (P = CONST) AND VARIABLE (P = VAR) PRESSURE SYSTEM

Proportional control of a cylinder consists in throttling the liquid stream both at its inlet and outlet [3].

The basic proportional control system is a system fed by the constant capacity pump. The overflow valve SP (Fig. 1a) determines the system nominal pressure. The pressure decrease in the cylinder compensates the load on the cylinder. The proportional directional valve generates two pressure drops at the cylinder inlet and outlet. The pump in the $p = \text{const}$ system must generate, before the overflow valve, pressure not lower than pressure required by the cylinder. Therefore, the hydraulic cylinder or the system working cylinder may require pressure, depending on the load, in the range from zero to the nominal value. When the load approaches the nominal value, pressure decrease in the directional valve throttling slots tends to zero. It may be said that the pump-overflow valve assembly in the $p = \text{const}$ system is ready to feed the system with the maximum pressure and maximum capacity, but most often it is not used to that extent as the working element is loaded with a force that requires pressure drop smaller than the

nominal value [3]. A constant pressure system achieves a high energy efficiency, equal to the efficiency of a system without throttling control, only at the point of maximum values of the controlled hydraulic linear motor load coefficient \bar{M}_M and speed coefficient $\bar{\omega}_M$. The system efficiency η decreases rapidly with decreasing motor load and particularly with simultaneous decreasing motor speed [2].

The variable pressure ($p = \text{var}$) structure is represented by a system with constant capacity pump cooperating with an overflow valve controlled by the cylinder inlet pressure (Fig. 1b). This is an advantageous solution from the viewpoint of the cylinder energy efficiency as well as of the pump and the whole control system efficiency. The variable pressure ($p = \text{var}$) structure with the overflow valve controlled by the current directional valve outflow to cylinder pressure allows to adjust the pump discharge conduit pressure to the current cylinder load, which limits the pressure loss in the working liquid outflow slot from the directional valve to the tank. Additionally, the system maintains constant piston speed irrespective of the load. This is an effect of maintaining practically constant pressure drop Δp_{DE1} in the proportional directional valve throttling slot [3].

Fig. 2 presents graphical interpretation of the power of energy losses in elements of an individual system with proportional control of a hydraulic cylinder, fed by a constant capacity pump cooperating with an overflow valve in a constant

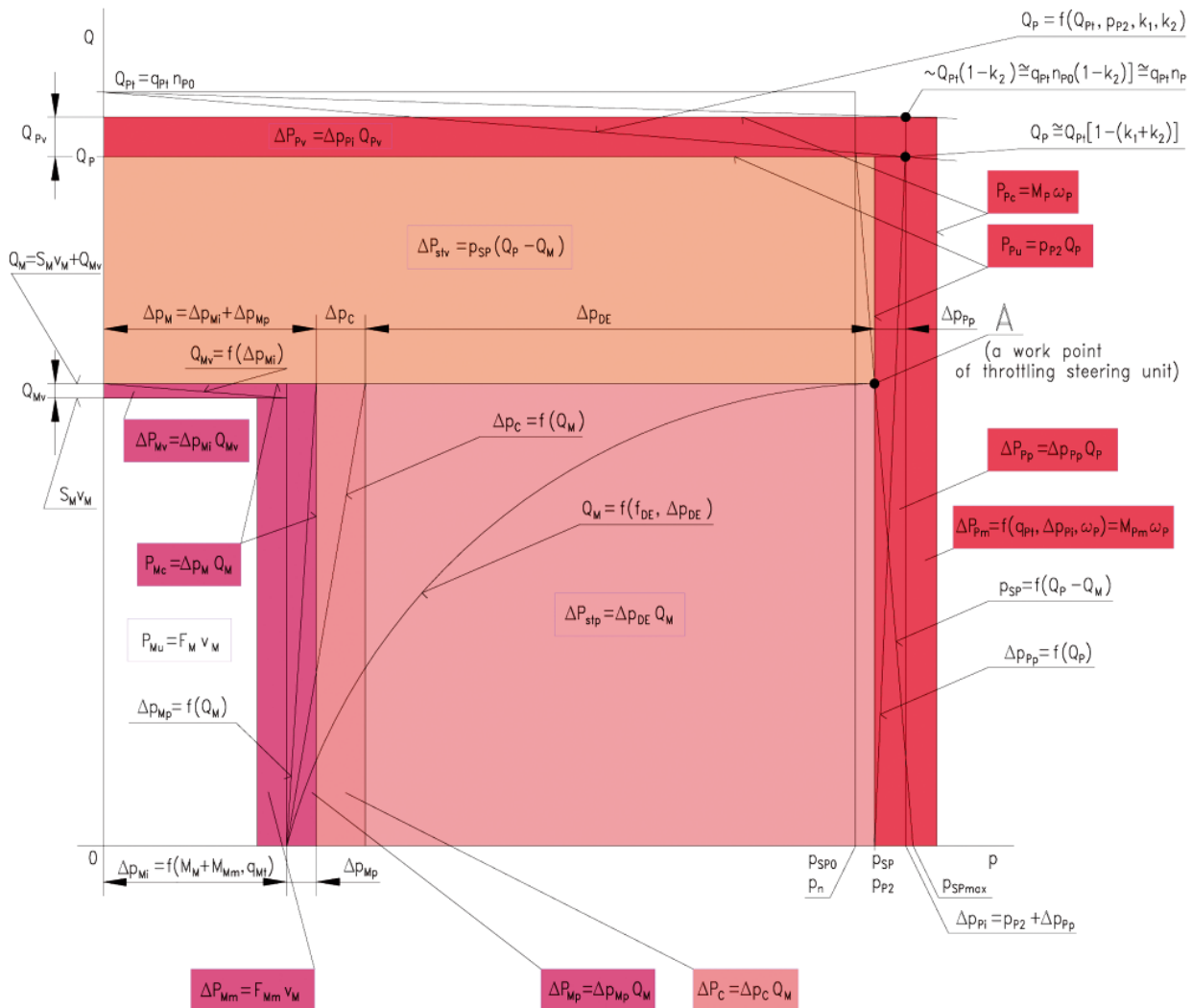

Fig. 2. Graphical interpretation of the power of losses in the hydrostatic drive and control system elements. An individual system with series throttling control of the hydraulic linear motor speed, fed by a constant capacity pump cooperating with the overflow valve in a constant pressure system – $p = \text{const}$; the series throttling control assembly in the form of [3]:
 - adjustable throttling valve; - adjustable two-way flow regulator; - servovalve; - proportional directional valve

pressure system ($p = \text{const}$), and Fig. 3 – with an overflow valve controlled in a variable pressure system ($p = \text{var}$).

The pump operation nominal pressure p_n is determined by the need to ensure the hydraulic linear motor a maximum pressure drop $\Delta p_{M\text{max}}$ to cope with the maximum force $F_{M\text{max}}$ on the cylinder piston rod that may occur from time to time as an effect of the cylinder load.

The current cylinder useful power $P_{Mu} = F_M v_M$ is a product of the cylinder piston rod force F_M and the piston rod speed. The hydraulic linear motor useful power P_{Mu} depends on the current load and is independent of the control structure and of the losses in the elements of a hydrostatic drive system with a specific structure [1].

In figure 2, the hydraulic linear motor current useful power $P_{Mu} = F_M v_M$ is presented as the area of the white rectangle, to which the following fields are “added”:

- field $\Delta P_{Mm} = F_{Mm} v_{Mm}$ of the power of mechanical losses in the cylinder,
- field $\Delta P_{Mv} = \Delta p_{Mi} Q_{Mv}$ of the power of volumetric losses in the cylinder,
- field $\Delta P_{Mp} = \Delta p_{Mp} Q_M$ of the power of pressure losses in the cylinder,
- field $\Delta P_C = \Delta p_C Q_M$ of the power of pressure losses in the system conduits,
- field $\Delta P_{stp} = \Delta p_{DE} Q_M$ of the power of structural pressure losses in the throttling control assembly (in the proportional directional valve),
- field $\Delta P_{stv} = p_{SP} (Q_p - Q_M)$ of the power of structural volumetric losses in the throttling control assembly (in the overflow valve),
- field $\Delta P_{Pp} = \Delta p_{Pp} Q_M$ of the power of pressure losses in the pump,
- field $\Delta P_{Pv} = \Delta p_{Ppi} Q_{Pv}$ of the power of volumetric losses in the pump,
- field $\Delta P_{Pm} = M_{Pm} \omega_p$ of the power of mechanical losses in the pump.

The sum of areas of the cylinder current useful power P_{Mu} rectangle and the ΔP rectangles representing the values of power of particular losses occurring at a given instant in the hydrostatic drive and control system elements, makes up the area of rectangle corresponding to the current power P_{pc} absorbed (consumed) by the pump from its driving electric motor and equal to the product of the current torque M_p and current pump shaft angular speed – $P_{pc} = M_p \omega_p$ [1].

The power P_{pc} absorbed by the pump from the driving motor may be greater than the reference power $p_n Q_{pt}$ – a product of the nominal pressure p_n and pump theoretical capacity Q_{pt} [1].

In figures 2 and 3 the pump capacity is represented by two descending lines originating at point Q_{pt} . The higher line illustrates the pump capacity in the situation when the pump volumetric loss coefficient k_1 has a zero value ($k_1 = 0$). The line below represents the pump capacity at $k_1 > 0$. The volumetric losses occur in the latter situation [3].

The Q_M curve presents the proportional directional valve characteristic with a given pressure drop Δp_{DE} in the directional valve and with a given throttling slot area f_{DE} (Fig. 2 and 3). At point “A” it crosses the overflow valve (SP) characteristic $p_{SP} = f(Q_p - Q_M)$. In effect, the intensity Q_M of flow through the throttling slot to the cylinder is obtained, and with a given piston and piston rod area – the speed v_M . The working point A is a result of the overflow valve SP and of the proportional directional valve characteristics [3].

The cylinder useful power P_{Mu} is a product of its speed v_M and load F_M . In other words, it is power developed by the cylinder on the piston rod. The cylinder useful power P_{Mu} field

is marked white to distinguish it from the power of losses in the system.

Power ΔP_{Mv} of volumetric losses is a function of the pressure drop Δp_{Mi} in the cylinder.

Power ΔP_{Mm} of mechanical losses is a function of the load force F_M .

Power ΔP_C of losses in the system conduits is a product of the sum of resistance of flow Δp_C and flow intensity Q_M towards the cylinder.

Power ΔP_{stp} of structural pressure losses is a product of the sum of pressure losses Δp_{DE} in the directional valve throttling slots and of the flow intensity Q_M corresponding to the cylinder speed v_M . It can be reduced almost to zero during cylinder operation at the $F_{M\text{max}}$ load.

Power ΔP_{stv} of structural volumetric losses is a product of pressure p_{SP} in the pump discharge conduit and of the flow intensity Q_0 directed, through the overflow valve SP or the controlled overflow valve SPS, to the tank [3]. It decreases almost to zero when the cylinder operates with maximum speed $v_{M\text{max}}$.

There are three types of losses in the pump.

Power ΔP_{Pm} of mechanical losses in the pump occurs between the pump working chamber and the shaft. It is proportional to the pump capacity per one revolution q_p and to the pressure increase Δp_{pi} in its working chambers. The Δp_{pi} value is influenced by the resistance of flow Δp_{pp} in the pump channels [3]. Fig. 2 presents the power of pump mechanical losses in the $p = \text{const}$ system as a field whose width is determined by the torque M_{pm} of mechanical losses and height corresponds to the pump shaft angular speed ω_p .

In the $p = \text{var}$ system (Fig. 1b and 3), the pump working pressure p_{p2} , controlled by the controlled overflow valve SPS, is set at a level higher by the value:

$$\Delta p_{SPS} = \Delta p_{DE1|f_{DE1\text{max}}, Q_{Pt}} + \Delta p_{C1\text{max}} = \text{cte}$$

than the current pressure p_2 in the throttling directional valve outlet conduit to the hydraulic linear motor. The value Δp_{SPS} of the pressure difference $\Delta p_{SPS} = p_{p2} - p_2$ must ensure obtaining, with the throttling directional valve slot DE1 controlling the flow intensity Q_M feeding the hydraulic linear motor, the flow intensity Q_M equal to the theoretical pump capacity Q_{pt} , i.e. $Q_M = Q_{pt}$. The slot cross-section area DE1 reaches then its maximum value $f_{DE1\text{max}}$, with a possibility of obtaining the $\Delta p_{DE1|f_{DE1\text{max}}, Q_{Pt}}$ drop required by the throttling directional valve structure and at the same time the capability of overcoming the maximum resistance of flow $\Delta p_{C1\text{max}}$ that may appear between the pump and the directional valve. The pressure value p_1 before the throttling directional valve slot DE1 is equal to $p_1 = p_{p2} - \Delta p_{C1}$ [1].

The current value of the pump discharge pressure p_{p2} , higher by Δp_{SPS} than the current p_2 value at the throttling directional valve outlet to the hydraulic linear motor, results from the pressure value p_{M1} required by the hydraulic cylinder at its inlet. The maximum limit pressure value $p_{p2\text{max}}$ in the pump discharge conduit is determined by the overflow valve SP, whose opening pressure p_{SP0} is equal to the system nominal pressure p_n [1].

In the $p = \text{var}$ system (Fig. 3), the width of the field of power ΔP_{Pm} of mechanical losses in the pump is proportional to the pressure and is smaller as the pressure in the pump working chambers is lower. In effect, it requires a smaller torque on the pump driving motor shaft [3].

The field ΔP_{Pp} of the power of pressure losses in the $p = \text{var}$ system pump is greater than the $p = \text{const}$ system ΔP_{Pp} .

The power ΔP_{Pv} of volumetric losses in a $p = \text{var}$ system pump is distinctly smaller than the power ΔP_{Pv} of those losses in a $p = \text{const}$ system pump.

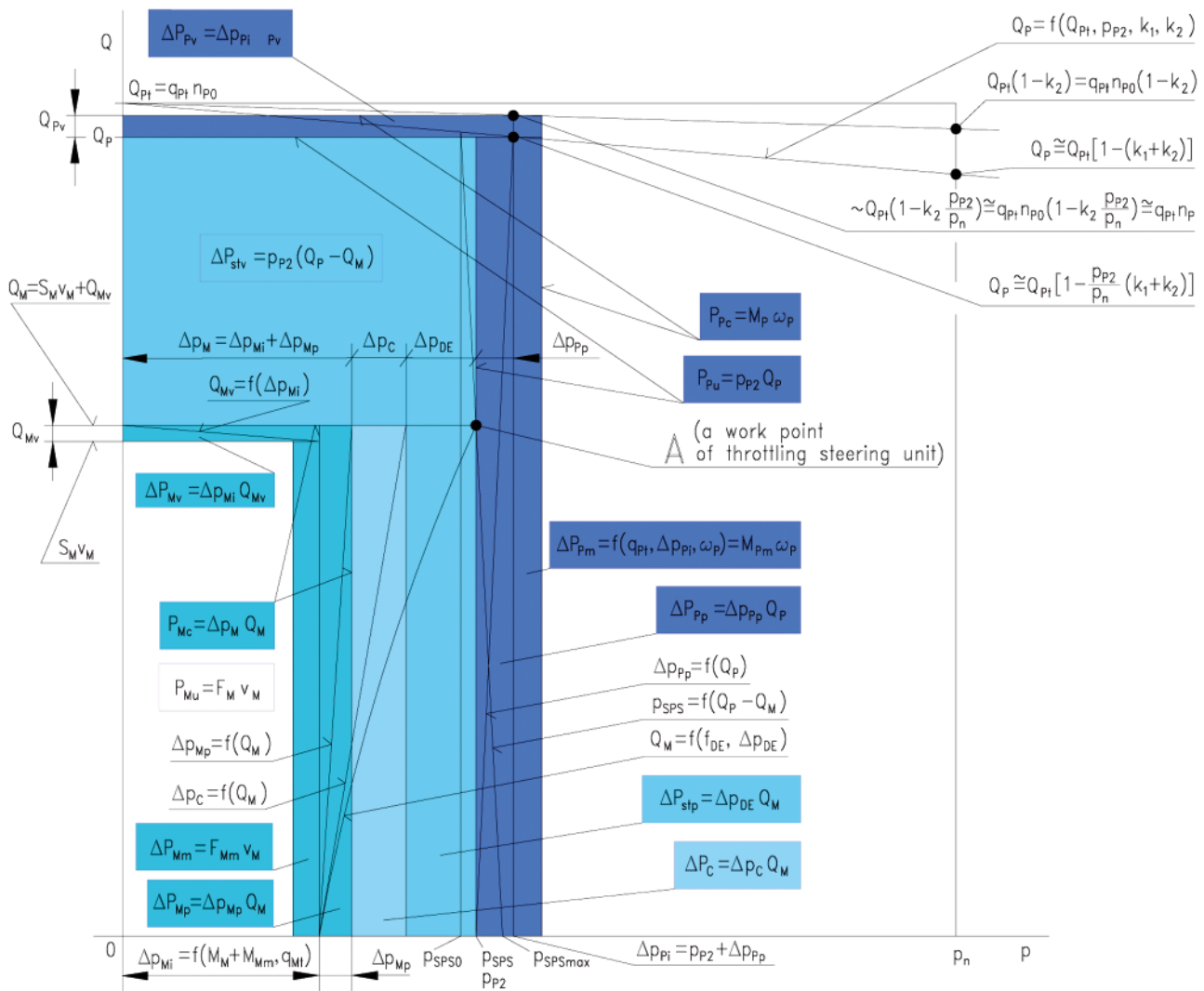

Fig. 3. Graphical interpretation of the power of losses in the hydrostatic drive and control system elements. An individual system with series throttling control of the hydraulic linear motor speed, fed by a constant capacity pump cooperating with the overflow valve in a variable pressure system – $p = \text{var}$; the series throttling control assembly in the form of [3]:
 - adjustable throttling valve (together with a controlled overflow valve, creating a three-way flow regulator); - servovalve; - proportional directional valve

The intensity Q_M of flow towards the hydraulic cylinder results from the pressure drop Δp_{DE1} and Δp_{DE2} in the proportional directional valve slots. On the other hand, those pressure drops change when the pressure drop Δp_M required by the hydraulic cylinder changes [3].

COMPARISON OF THE AREAS OF FIELDS OF THE POWER OF ENERGY LOSSES IN THE ELEMENTS OF TWO STRUCTURES – $P = \text{CONST}$ AND $P = \text{VAR}$

Figures 4 to 9 present graphical interpretation of the power of losses in the hydrostatic drive and control system elements, investigated in a constant pressure ($p = \text{const}$) and variable pressure ($p = \text{var}$) system, with the hydraulic cylinder load values $F_M = 10 \text{ kN}$, 25 kN and speed values $v_M = 0.05 \text{ m/s}$, 0.20 m/s and 0.35 m/s . The fields of power of losses ΔP in the constant pressure system are shaded red and fields of power of losses in the variable pressure system - shaded blue.

At the cylinder zero load $F_M = 0$ there is no field of the cylinder useful power P_{Mu} and only losses occur in the $p = \text{const}$ and $p = \text{var}$ system.

In Fig. 4, at the cylinder load $F_M = 10 \text{ kN}$ and speed $v_M = 0.05 \text{ m/s}$, great structural volumetric losses ΔP_{stv} are visible in the SP overflow valve, as with small cylinder speed

the flow intensity Q_M towards the cylinder is small. Most part of the flow intensity Q_P generated by the pump is directed to the tank as the Q_0 intensity.

Fig. 5 illustrating a variable pressure ($p = \text{var}$) structure shows structural volumetric losses ΔP_{stv} , occurring in the controlled overflow valve SPS, the greatest among the losses as with small cylinder speed the flow intensity Q_M towards the cylinder is small. Most part of the flow intensity Q_P generated by the pump is directed to the tank in the form of a Q_0 intensity. At the same time, power ΔP_{stv} of volumetric losses is much smaller here than ΔP_{stv} in the $p = \text{const}$ system (Fig. 4), as the pump working pressure p_{p2} , set with the controlled overflow valve, is much lower.

Comparing the energy balance of the $p = \text{var}$ system shown in Fig. 5 with the $p = \text{const}$ system balance shown in Fig. 4, with the same cylinder load and speed coefficients, one can notice much smaller structural losses ΔP_{st} in the proportional directional valve and in the controlled overflow valve as well as the pump volumetric losses ΔP_{pv} in the $p = \text{var}$ system. This is connected with adjusting the p_{p2} pressure in the pump discharge conduit to the current cylinder load, i.e. to the p_2 pressure. As Fig. 5 illustrates the energy balance of a $p = \text{var}$ system under a small load, losses in the system are smaller.

Losses in the conduits are the smallest in this case, as the power of losses in the conduits ΔP_C is a product of the sum

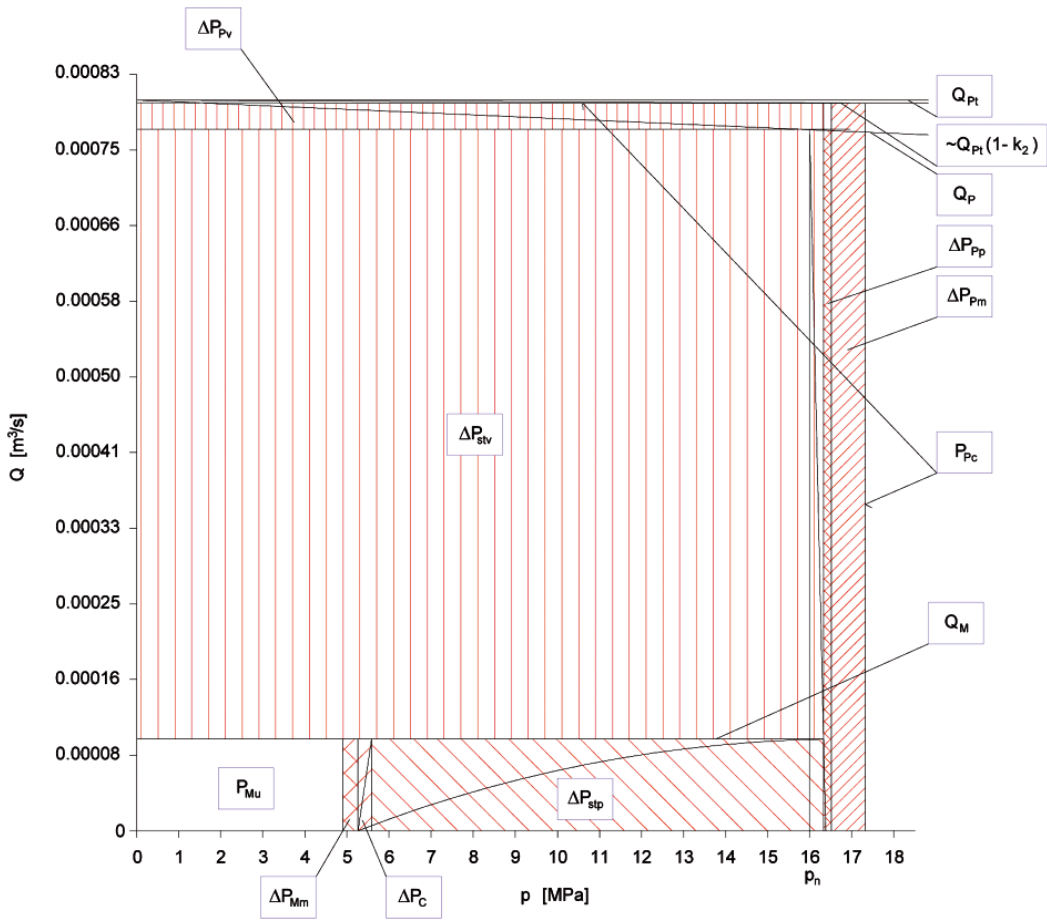

Fig. 4. Energy balance of a constant pressure ($p = \text{const}$) system investigated at the cylinder load $FM = 10\text{kN}$ and speed $v_M = 0.05\text{m/s}$

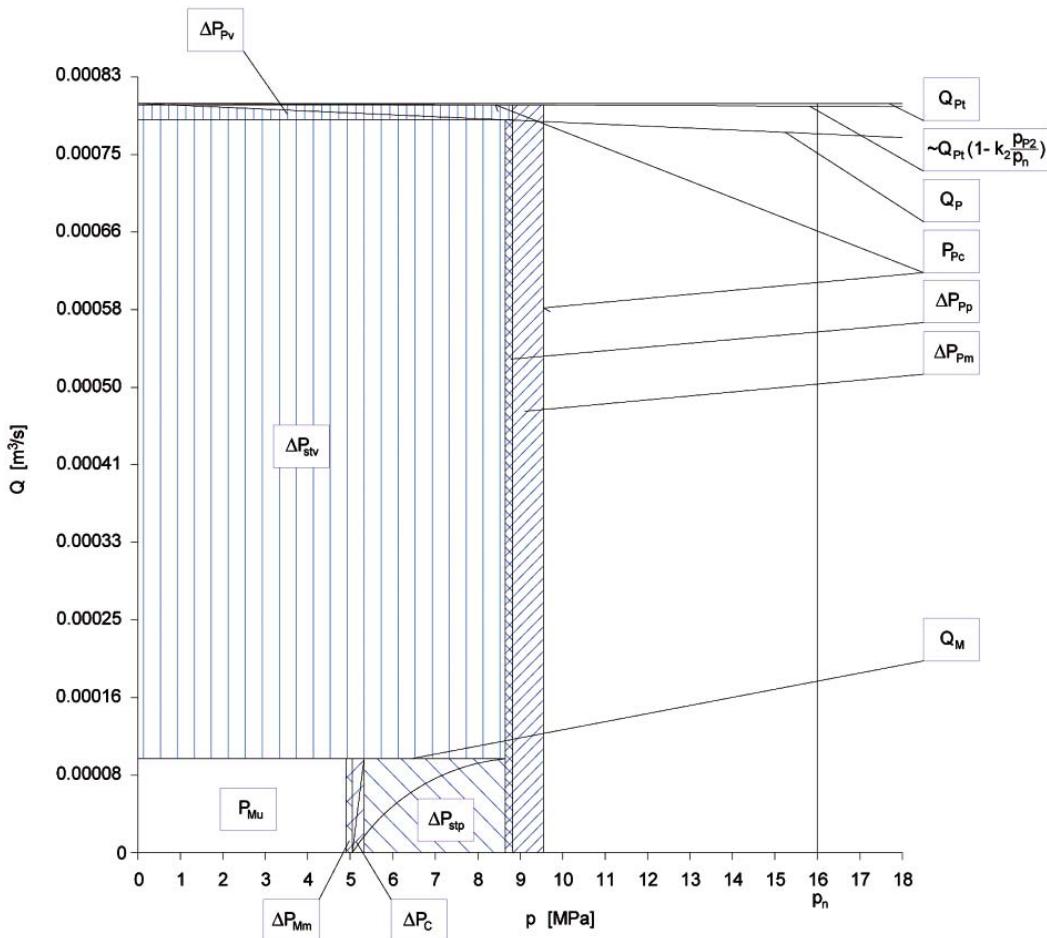

Fig. 5. Energy balance of a variable pressure ($p = \text{var}$) system investigated at the cylinder load $FM = 10\text{kN}$ and speed $v_M = 0.05\text{m/s}$

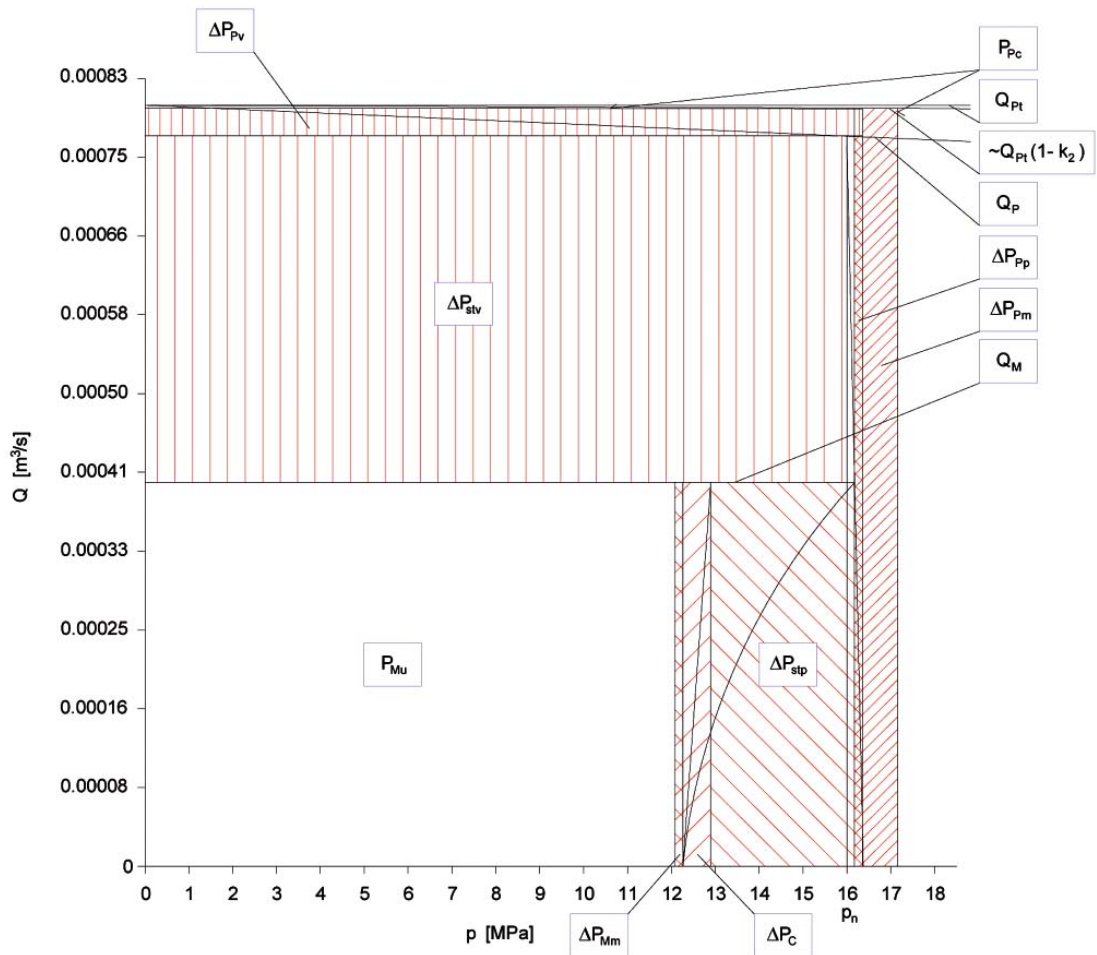

Fig. 6. Energy balance of a constant pressure ($p = \text{const}$) system investigated at the cylinder load $FM = 25\text{kN}$ and speed $vM = 0.20\text{m/s}$

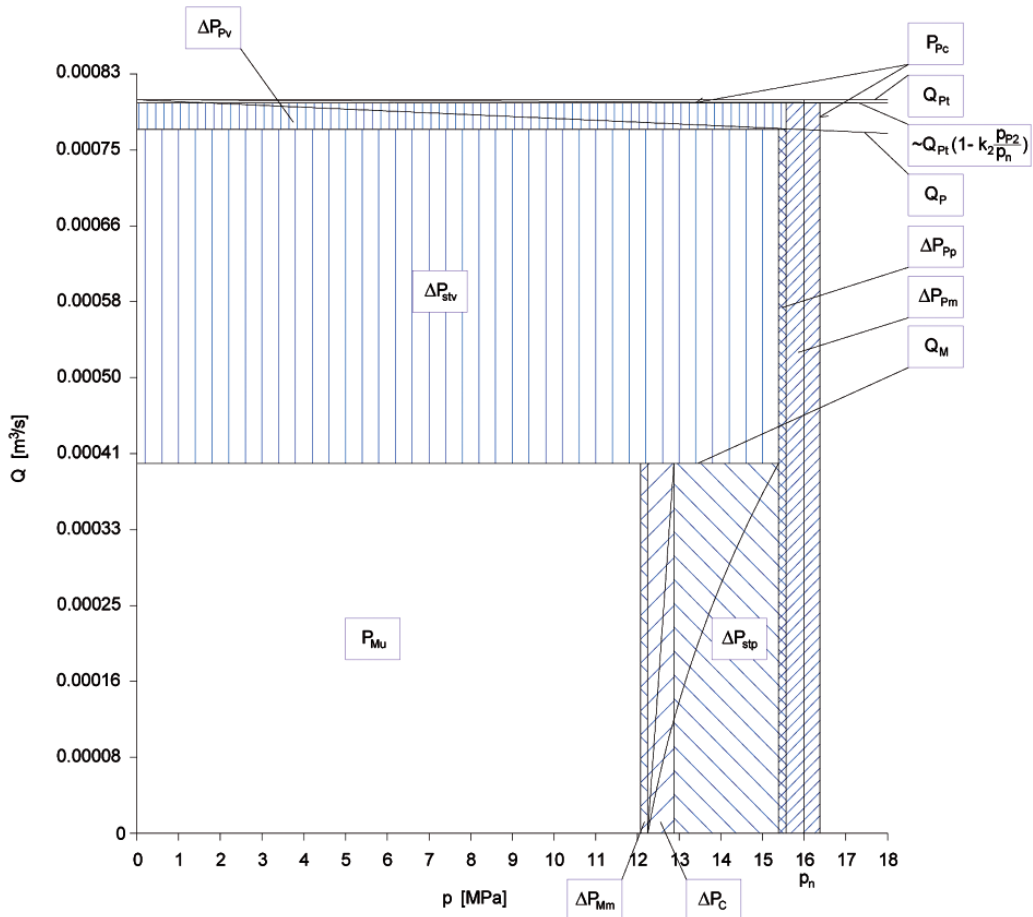

Fig. 7. Energy balance of a variable pressure ($p = \text{var}$) system investigated at the cylinder load $FM = 25\text{kN}$ and speed $vM = 0.20\text{m/s}$

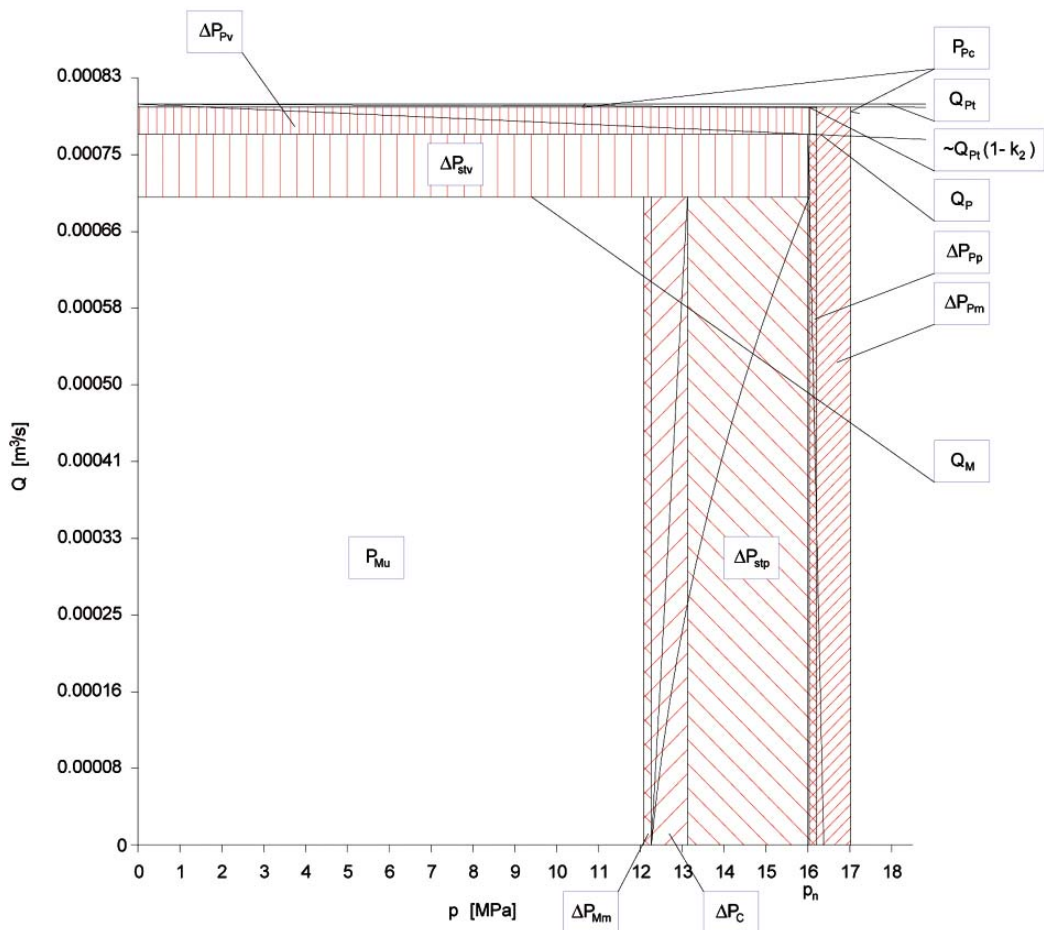

Fig. 8. Energy balance of a constant pressure ($p = \text{const}$) system investigated at the cylinder load $FM = 25\text{kN}$ and speed $vM = 0.35\text{m/s}$

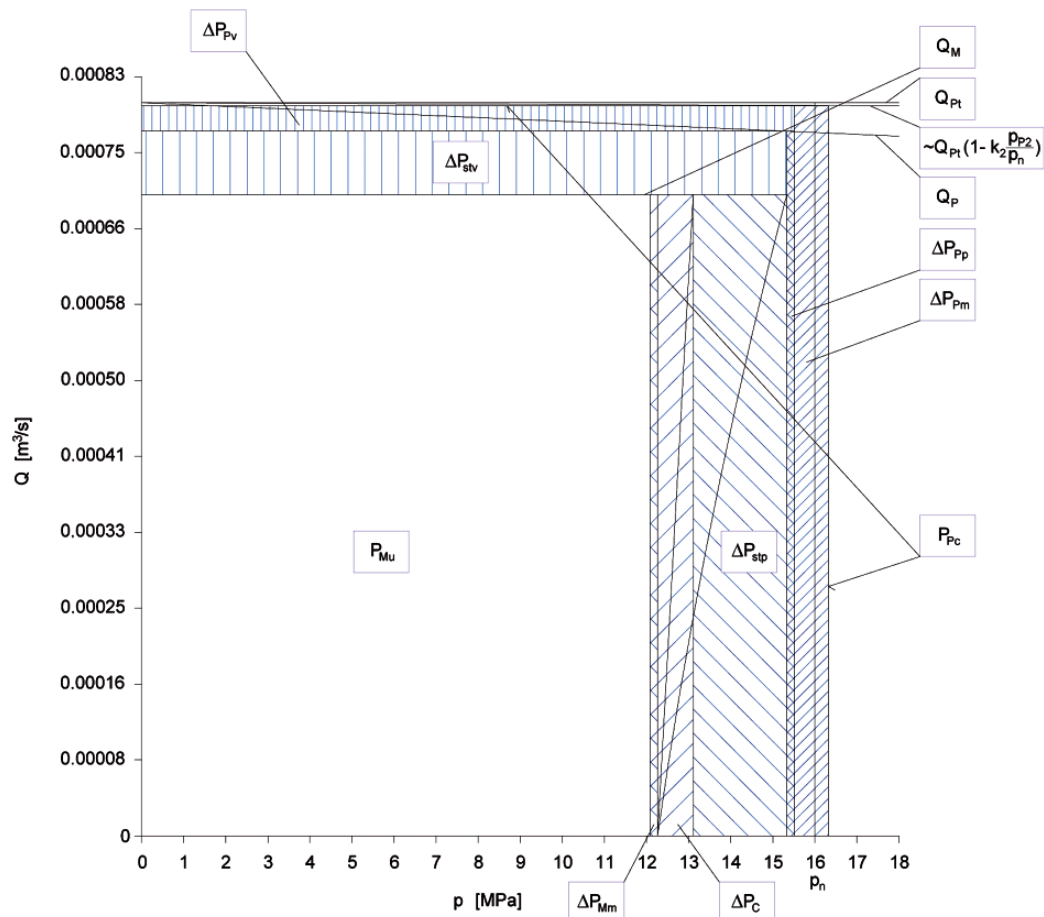

Fig. 9. Energy balance of a variable pressure ($p = \text{var}$) system investigated at the cylinder load $FM = 25\text{kN}$ and speed $vM = 0.35\text{m/s}$

of resistance of flow Δp_c and flow intensity Q_M towards the hydraulic cylinder, and that intensity is small due to small cylinder speed $v_M = 0.05$ m/s.

Figures 6 and 7 present the field P_{Mu} of the hydraulic cylinder useful power (white field) and the fields of the power ΔP of losses that occur in the $p = \text{const}$ system (Fig. 6) and $p = \text{var}$ system (Fig. 7) at the cylinder speed $v_M = 0.20$ m/s and cylinder load $F_M = 25$ kN. The fields of power ΔP of losses are shaded red.

The share of structural volumetric losses ΔP_{stv} and pressure losses ΔP_{stp} in the total energy balance of a constant pressure system is relatively great compared with other losses in the elements. The pressure energy accumulated in the liquid pressed by the pump is only partially used effectively in the cylinder. The remaining power, presented in the form of losses ΔP , is a loss of power. The greatest share in the losses have the ΔP_{stv} losses connected with the SP overflow valve. The pressure drop in the directional proportional valve is integrally connected with the system operation, as it decides the flow intensity and hydraulic cylinder speed. As the cylinder speed is assumed equal to $v_M = 0.20$ m/s and the load equal to $F_M = 25$ kN, the ΔP_{stp} losses are the second greatest losses in the system. Noteworthy is here much greater field P_{Mu} of the cylinder useful power compared with that field presented in Fig. 4. This is also connected with higher cylinder speed.

Also noteworthy in the presented figures are losses connected with the pump. Although they make a small part of the total losses, they are next in size to the structural losses ΔP_{st} in the system. Mechanical losses ΔP_{pm} are in the first place. The field of pump volumetric losses ΔP_{pv} is smaller and the field of pump pressure losses is smaller than that of the volumetric losses.

In figures 6 and 7 the field of cylinder useful power P_{Mu} is a smaller part of the field P_{pc} of power absorbed by the pump. This is connected with the hydraulic cylinder small load and small speed. As the power of mechanical losses ΔP_{Mm} in the cylinder is a function of the loading force F_M , the field of power of those losses is also small compared with other losses in the system.

Comparing the energy balance of a $p = \text{var}$ system presented in Fig. 7 with the balance of a $p = \text{const}$ system shown in Fig. 6 with the same cylinder speed and load coefficients, it can be noted that the structural losses ΔP_{st} in the proportional directional valve and in the controlled overflow valve as well as the pump volumetric losses ΔP_{pv} in a $p = \text{var}$ system are smaller due to the smaller pump discharge pressure p_{p2} .

Also smaller is power ΔP_{pm} of the pump mechanical losses.

Figures 8 and 9 present the energy balance of an investigated constant pressure ($p = \text{const}$) and variable pressure ($p = \text{var}$) system with the hydraulic cylinder $F_M = 25$ kN load and $v_M = 0.35$ m/s speed. It can be seen that structural losses are much smaller than in the case of limited or partial use of the cylinder speed and load, which is presented in figures 4 to 7. The pressure losses ΔP_c in the conduits increased due to higher cylinder speed.

Comparing the energy balance of the $p = \text{var}$ system shown in Fig. 9 with the balance of the $p = \text{const}$ system in Fig. 8, with the same cylinder speed and load coefficients, it can be noted that the balances are similar in the sense of areas of the corresponding fields.

Structural losses are much smaller than in the case of limited or partial use of the cylinder speed and load. Mechanical losses ΔP_{Mm} in the cylinder and pressure losses ΔP_c in the conduits increased due to higher cylinder speed and load.

SUMMARY AND CONCLUSIONS

The hydrostatic drive energy efficiency is a product of the efficiencies of drive system components. Efficiency of the component elements is, in turn, a product of the mechanical, pressure and volumetric efficiency of those elements. While determining those efficiencies, the power of losses in the elements is not taken into account, but only torque or force of the mechanical losses, pressure losses in the conduits or intensity of the volumetric losses. It is acceptable in the case of rotational pumps and motors and double-piston rod cylinders. However, it is not sufficient in considering the energy efficiency of commonly used linear motors, single-piston rod cylinders and systems with those machines. Therefore, not always justified simplifying assumptions are applied [3].

Full picture of the energy losses in a hydrostatic drive system is a picture of the power of energy losses in the system elements. The system feeding pump shaft power is equal to the sum of the hydraulic motor shaft or piston rod power plus powers of losses occurring in the energy stream flowing through the component elements. Power delivered to the system on the pump shaft is also influenced by the interrelation between the pump driving motor speed $n_p = n_{Mm}$ and the pump shaft torque M_p . Powers of the energy losses in the system elements and also powers developed by the elements must be precisely defined. The picture of energy losses requires the range to be determined of the hydraulic motor useful power P_{Mu} , determined in turn by the range of torque M_M and angular speed ω_M of a rotational motor shaft, or force F_M and linear speed v_M of a linear motor. The picture of energy losses in a hydrostatic drive system should be built from the hydraulic rotational motor shaft or linear motor piston rod towards the system feeding pump shaft [4, 5].

CONCLUSIONS

1. The impact is presented of the P_{Mu} power on the P_{pc} power in the analysed systems and also the impact of power ΔP of losses in the elements on the P_{pc} power. The hydraulic cylinder instantaneous useful power P_{Mu} , defined as a product of force F_M and cylinder piston rod speed v_M , is independent of all the losses. The following powers should be added to the useful power P_{Mu} : power ΔP_{Mm} of mechanical losses in the cylinder, power ΔP_c of losses in conduits, power ΔP_{stv} of structural volumetric losses and power ΔP_{stp} of structural pressure losses connected with the throttling control, as well as powers of the pump losses: pressure losses ΔP_{pp} , volumetric losses ΔP_{pv} and mechanical losses ΔP_{pm} . The sum of the useful power P_{Mu} and the ΔP power of all the system losses determines the instantaneous value of the P_{pc} power that the pump requires of its driving motor.
2. The analysis of the power of losses has been performed; for instance, in the $p = \text{const}$ system (Fig. 4), power ΔP_{Mm} of mechanical losses in the cylinder is smaller than power ΔP_{pm} of mechanical losses in the pump. In the $p = \text{var}$ system (Fig. 5), powers of losses ΔP_{Mm} and ΔP_{pm} are smaller; also here the ΔP_{Mm} is smaller than the ΔP_{pm} power.
3. It has been shown that with cylinder unchanged load F_M and its increased speed v_M , the power of structural pressure losses ΔP_{stp} increases, because the intensity of flow through the proportional directional valve is increased (Figures 6 to 9).
4. The change of structure from $p = \text{const}$ to $p = \text{var}$, with the same system useful power P_{Mu} , brings in effect a serious decrease of the power ΔP_{st} of structural losses (Figures 8 and 9). Simultaneously, at the same cylinder speed v_M , in

- the $p = \text{var}$ structure, the power ΔP_{pv} of volumetric losses in the pump and power ΔP_{pm} of mechanical losses in the pump decrease, but power ΔP_{pp} of pressure losses in the pump slightly increases.
5. Comparing the energy balance of the $p = \text{var}$ system with the $p = \text{const}$ system balance, with the same greatest values of the hydraulic cylinder speed coefficient $\bar{\omega}_M$ and load coefficient \bar{M}_M it can be noticed that those energy balances are close to each other in the sense of size of the field of power of losses (Fig. 8 and 9).
 6. Considerable decrease of the power of pump structural losses ΔP_{st} and power of volumetric losses ΔP_{pv} in the $p = \text{var}$ system in relation to the $p = \text{const}$ system can be seen with smaller hydraulic cylinder loads. This is connected with lower p_{p2} pressure in the $p = \text{var}$ system, because a system with the overflow valve controlled by the current pressure p_2 of outflow from the directional valve to the cylinder inlet chamber allows to adjust the p_{p2} pressure in the pump discharge conduit to the current cylinder load, i.e. the p_2 pressure, in such a way that pressure loss Δp_{DE1} in the directional valve slot f_{DE1} and pressure loss Δp_{DE2} in the directional valve slot f_{DE2} are limited. The Δp_{DE1} pressure drop in the directional valve is smaller than the Δp_{DE1} drop in the $p = \text{const}$ system. In connection with lower p_{p2} pressure, the power P_{pc} absorbed by the pump is significantly lower (Fig. 4 and 5).
 7. With small hydraulic cylinder speed v_M and small load F_M it can be noticed, that in spite of using a constant capacity pump, the power of structural pressure losses ΔP_{stp} and also power of structural volumetric losses ΔP_{stv} is considerably smaller in the $p = \text{var}$ system compared with the $p = \text{const}$ system. Although the intensity of flow Q_0 through the overflow valve to the tank with the same cylinder speed v_M is in the compared systems practically the same, the product of smaller pump discharge pressure p_{p2} and the flow intensity Q_0 (the $Q_p - Q_M$ difference) results in a smaller value of the power ΔP_{stv} of structural volumetric losses in the $p = \text{var}$ system (Fig. 4 and 5).
 8. Power ΔP_C of losses in the conduits is great at a great value of flow intensity Q_M towards the hydraulic cylinder (Fig. 8 and 9) compared with the power ΔP_{pp} of pressure losses in the pump. In the investigated $p = \text{const}$ and $p = \text{var}$ systems, in the individual conduit sections many elements are installed (filters, conduit connections, cut-off valves in fully opened position, temperature sensors), which change the direction or speed of flow in the conduits. Therefore, even greater pump capacity Q_p causes smaller flow resistance in the pump channels (which in the drawing corresponds to smaller width of the field of power ΔP_{pp} of losses) than the flow resistance in the conduits (which in the drawing corresponds to the width of the field of power ΔP_C of losses).
 9. Power ΔP_{Mm} of mechanical losses in the hydraulic cylinder changes with the change of pressure in its chambers. In a variable pressure system power ΔP_{Mm} of mechanical losses is smaller than in the $p = \text{const}$ system, as the F_{Mm} force of friction losses in the cylinder is smaller (Fig. 4 and 5).
 10. With increasing the hydraulic cylinder speed v_M and load F_M to the maximum values v_{Mmax} and F_{Mmax} respectively, the power ΔP_{stv} of structural volumetric losses and power ΔP_{stp} of structural pressure losses, connected with the throttling control assembly, is minimized.
 11. When the hydraulic cylinder does not displace (when its speed is equal to zero - $v_M = 0$) and the pump operates, the cylinder useful power P_{Mu} is equal to zero; the following powers of losses occur in the system: power ΔP_{stv} of structural volumetric losses and powers of losses in the pump: pressure losses ΔP_{pp} , volumetric losses ΔP_{pv} and mechanical losses ΔP_{pm} . The sum of those powers is equal to the power P_{pc} absorbed by the pump. With smaller loads F_M of the stopped cylinder, power P_{pc} absorbed by the pump in the $p = \text{var}$ system is smaller than power P_{pc} in the $p = \text{const}$ system
 12. The presented energy balances indicate that power P_{pc} absorbed by the pump (with the same cylinder useful power P_{Mu}) is different in two investigated systems. Pump operating in the $p = \text{const}$ system with constant capacity and nominal pressure p_n absorbs all the time much greater power P_{pc} than in the $p = \text{var}$ system. Apart from the wasted power, elements of the constant pressure system get worn out faster and hydraulic oil as the working medium is also used faster.
 13. Presentation of the energy balance of investigated systems by means of graphical interpretation as fields of power of energy losses shows in a legible and simple way the powers in the system and powers of losses in the elements, dependent on the hydraulic cylinder speed v_M and load F_M , on the speed v_M throttling control structure and on the quality of the system component elements. This is the first example of the changes of fields of power ΔP of losses in the elements and of power P_{pc} absorbed by the pump, as a function of the hydraulic cylinder useful power P_{Mu} .
 14. The variable pressure system has clearly smaller, compared with the constant pressure system, power of structural pressure losses in the throttling control assembly during a decreasing external load on the hydraulic linear motor. Also power of structural volumetric losses in the controlled overflow valve decreases, although the intensity of flow of the volumetric losses in that valve slightly increases compared with the constant pressure system due to greater pump capacity. In the pump operating in a variable pressure system, slight increase occurs of the power of pressure losses, decrease of the power of volumetric losses and also decrease of the power of mechanical losses. In effect, during a small load on the hydraulic linear motor, a decrease is noticed of the power absorbed by the pump from its driving electric motor, which, with unchanged useful power of the hydraulic linear motor, significantly increases the energy efficiency of the whole system compared with the constant pressure system efficiency.
 15. The two compared systems may achieve, during operating with maximum load and maximum speed, the same maximum overall efficiency. The variable pressure system becomes then a constant pressure system and the working conditions of both systems are the same.

BIBLIOGRAPHY

1. Paszota Z.: *Graphical presentation of the power of energy losses and power developed in the hydrostatic drive and control system elements. Part I – Systems with the series throttling control of the hydraulic rotational motor speed.* Chapter in the monograph: "Research, design, manufacturing and operation of hydraulic systems". Adam Klich, Edward Palczak and Andrzej Meder editors, "Cylinder" Library (in Polish), Centrum Mechanizacji Górnictwa „Komag”, Gliwice 2008, p. 121-139, figures: 12, bibliographic positions: 10.
2. Paszota Z.: *Model of losses and energy efficiency of a hydraulic system with proportional control of the cylinder fed by a constant capacity pump in a variable pressure system.* Chapter in the monograph: "Research, design, manufacturing and operation of hydraulic systems". Edward Palczak editor, "Cylinder" Library (in Polish). Centrum Mechanizacji

- Górnictwa „Komag”, Gliwice 2005, p. 145-162, figures: 6, bibliographic positions: 8.
3. Skorek G.: *Energy characteristics of a hydraulic system with proportional control of the cylinder fed by a constant capacity pump in a constant and variable pressure system*. Doctor dissertation (in Polish), Gdansk University of Technology, Faculty of Ocean Engineering and Ship Technology, Chair of Ship and Ocean Engineering Equipment, Gdansk 2008, 253 pages, 141 figures, 62 bibliographic positions.
 4. Paszota Z.: *Power of energy losses in the hydrostatic drive system elements – definitions, relations, change ranges, energy efficiencies. Part I – Hydraulic motor*. Chapter in the monograph: "Research, design, manufacturing and operation of hydraulic systems". Andrzej Meder and Adam Klich editors, "Cylinder" Library (in Polish). Centrum Mechanizacji Górnictwa „Komag”, Gliwice 2007, p. 99 – 120, figures: 3, bibliographic positions: 6.
 5. Paszota Z.: *Power of energy losses in the hydrostatic drive system elements – definitions, relations, change ranges, energy efficiencies. Part II – Conduits, throttling control assembly, pump*. Chapter in the monograph: "Research, design, manufacturing and operation of hydraulic systems". Andrzej Meder and Adam Klich editors, "Cylinder" Library (in Polish). Centrum Mechanizacji Górnictwa „Komag”, Gliwice 2007, p. 121 – 139, figures: 1, bibliographic positions: 6.

CONTACT WITH THE AUTHOR

Grzegorz Skorek, Ph.D.
Department of Engineering Sciences
Faculty of Marine Engineering,
Gdynia Maritime University
Morska 81/87
81-225 Gdynia, POLAND
e-mail: grzesko@am.gdynia.pl