

**COMPUTER SIMULATION OF VIBRATION
SURVEILLANCE OF DISCRETELY IDEALISED
MECHANICAL SYSTEMS.
PART II: TOOL-WORKPIECE VIBRATION
IN A NON-STATIONARY MODEL
OF THE CUTTING PROCESS**

KRZYSZTOF J. KALIŃSKI

*Faculty of Mechanical Engineering, Gdansk University of Technology,
Narutowicza 11/12, 80-952 Gdansk, Poland
kkalinsk@sunrise.pg.gda.pl*

(Received 29 August 2003; revised manuscript received 4 November 2003)

Abstract: The problems of tool-workpiece vibration surveillance during machining have been researched. The object of investigation has been analysed, and cutting dynamics and calculation model creation described. Various approaches to and computer simulations of non-stationary model vibration surveillance are explained, based upon optimal spindle speed control and step-changing spindle speed control. A procedure is developed for computer prediction of results of the programme-controlled spindle speed surveillance strategy. Performance results are compared with those measured on a VMC FADAL 4020HT milling machine.

Keywords: machine tools, modelling, control, simulation

1. Introduction

Tool-workpiece relative vibration during the cutting process is extremely inconvenient from the point of view of dynamic properties of the machine tool system. Under certain conditions it may lead to a loss of stability and generate self-excited vibrations called *chatter*. Researchers have tried to prevent *chatter* by the following means [1, 2]:

- Spindle speed regulation by matching the eigenfrequency of the system [3]. It depends upon such adjustment of the frequency of the edge pass, that it should be equal to that of *chatter* vibration. Also, the development of resonant forced vibration is disturbed due to thickness of the cutting zone being variable in time. Once a *chatter* vibration is detected, feed should be stopped immediately, or accelerated tool wear will occur. Switching the feed on again results in a relatively long suspension time of free vibration. Moreover, the edge leaves

a wavy trace on the cut surface, which increases the danger of kinematically-excited vibration near the resonant zone.

- Spindle speed pulse control [4–6]. Some experiments have proven that cutting with periodically changing spindle speed prevents *chatter* vibration in a wide range of speed values. Recommended amplitudes of the pulse spindle speed are within the limits of 10–15% of the desired value, while pulse frequencies – up to 14Hz. However, no recommendation concerning the choice of an optimal value has been given, all the more so as the development of *chatter* is observed in some cases [7].
- Spindle speed regulation by matching it to the optimal phase shift between two subsequent passes of tool edges [1, 2, 8]. A state of vibration is monitored by a special computer system, which generates a spindle speed control command in real time. There is no need to identify the machine tool structure or disconnect the feed during machining.
- Permanent increase of the cutting speed [9]. Modern production techniques, in which spindle speeds reach up to a few ten-thousands rev/min and feed speeds – up to a few tens m/min, guarantee high quality and productivity at significantly lesser depths of cutting. They also meet the high quality requirements of finishing manufacturing. It results in saving up to 80% of time, or a 30% saving in manufacturing cost.

Despite various attempts, no effective method of dealing with the problem of *chatter* suppression has been developed thus far. Moreover, experimental research of the strategies of *chatter* avoidance is time-consuming and very expensive. Therefore, a new approach towards computer prediction of tool-workpiece vibration surveillance is proposed. It first makes use of a computer simulation of the cutting model, with the subsequent real performance of the cutting process.

2. Major requirements for machine tools [1, 2]

Modern machine tools are preferred for successful use of the available methods of tool-workpiece vibration surveillance. In this case, investigation of implementation of vibration control strategies is fully reasonable, as they secure meeting all the conditions concerning:

- a rigid carrying system, the effect of which on the dynamics of the cutting process is unnoticeable;
- small inertia of the main driving system, which favours structures with short kinematic chains and the motor installed directly on the spindle (the so-called electrospindles);
- a production process in which some problems with meeting technological criteria (*e.g.* surface quality, tool life, productivity) are observed due to the danger of *chatter*;
- a possibility of utilising the standard CNC control system of the machine tool for programming surveillance strategies;
- a possibility of co-operation between the standard CNC control system and an external spindle speed control device.

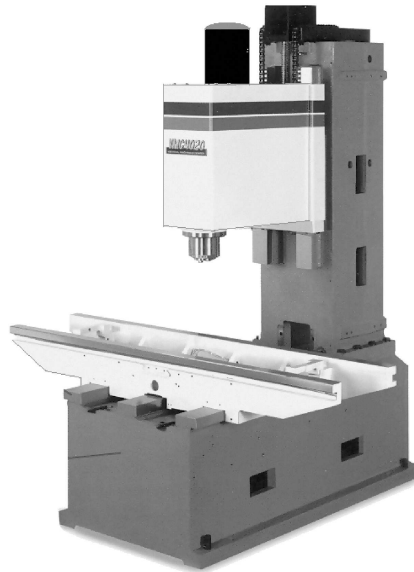

Figure 1. VMC FADAL 4020HT vertical milling centre

An American vertical milling centre, VMC FADAL 4020HT (Figure 1), has been chosen as an object of the investigation, as it satisfies the above mentioned requirements.

3. Dynamics of the cutting process

A face milling process by a slender-end mill is the object of our considerations. Cutting with slender tools is observed very frequently in modern machining centres. Its technological reason lies in the necessity of making hobbings access to which is difficult (*e.g.* die pockets). Slender-end milling is frequently treated as finishing work, so that high demands on the accuracy of machining are strictly observed, even at significant cutting depths. Considerable depths of cut may also occur during manufacturing the first row. A study of the dynamics of the machining process has been performed basing upon the following assumptions [1]:

- Some subsystems executing the desired relative motions are separated from the machine tool structure, *viz.* the spindle with the tool fixed in the holder and the table with the workpiece. A computer simulation of the dynamic behaviour of some flexible machine tools has proven that the above mentioned elements significantly affect the dynamics of the cutting process, while the contribution of other parts of the machine is minimal [10]. Thus, because of the more rigid structure of contemporary machine tools, the above rule seems to be clear.
- Only the flexibility of the slender tool has been considered. Other elements of the structure, including the main driving system, are idealised as perfectly rigid. Former experimental investigations of the cutting process, performed on VMC FADAL 4020HT using a short-end mill, have demonstrated a lack of any essential influence of the dynamic properties of the structure, even at extreme cutting depth values (up to 15mm) [1]. Also, the measurement procedures of

its main driving system have shown that its first eigenfrequency is very high, above 1500Hz.

- The effect of the cutting process has been considered as a closed-loop interaction, and coupling elements (CE) have been applied for modelling [1, 2].
- Cutting dynamics has been described using the proportional model [1], due to the anticipated high values of cutting velocity (above 100m/min) and the expected values of *chatter* frequency in the range of a few hundred Hz [11].
- An effect of the first pass of the edge along the cutting layer is proportional feedback, but an effect of multiple passes is additional, delayed feedback.

The above are reasons for the use of a simplified model of the milling process for computer simulation (Figure 2). It has six degrees of freedom and is composed of a beam flexible finite element (DFE) no. e of length L , fixed at its upper end, and coupling elements (CE), whose positions refer to instantaneous positions of mill edge tops and, obviously, vary with time [1]. The tool-workpiece conventional contact point S is introduced. Denoted here are generalised directions x_1, x_2, x_3 for this point, as well as generalised co-ordinates x_{e1}, x_{e2}, x_{e3} of the DFE.

The tool is spinning with the speed of revolution n , while the workpiece is moved with the desired feed speed v_f . The length of the machined specimen is L_w , while the widths of milling are B_1 and B_2 .

An instantaneous position of the edge top of the milling cutter, defined by the immersion angle $\varphi_l = \varphi_l(t)$, is idealised by CE no. l , while axes y_{l1}, y_{l2}, y_{l3} are the desired axes of feedback interaction of this CE. It has also been assumed that:

- the edge geometry elements are: the rake angle, γ_0 , the inclination angle, λ_s , and the main cutting angle, κ_r ;
- the actual cutting layer thickness is h_l , while the cutting force acting along it is F_{yl2} ;
- the actual cutting depth is a_p , and that the desired width, b_D , is derived from the relationship $b_D = a_p / \sin \kappa_r$;
- the main cutting force, F_{yl1} , is acting along the direction of the cutting speed.

We may transform displacements from the y_{l1}, y_{l2}, y_{l3} system to the x_1, x_2, x_3 system with the following matrix:

$$\check{\Theta}_l(t) = \begin{bmatrix} 1 & 0 & 0 \\ 0 & \sin \kappa_r & \cos \kappa_r \\ 0 & -\cos \kappa_r & \sin \kappa_r \end{bmatrix} \begin{bmatrix} \cos \varphi_l(t) & -\sin \varphi_l(t) & 0 \\ \sin \varphi_l(t) & \cos \varphi_l(t) & 0 \\ 0 & 0 & 1 \end{bmatrix}. \quad (1)$$

If we consider a proportional description of the cutting process and the effect of inner and outer modulation [1, 2], instantaneous cutting force components will be determined for CE no. l as follows:

$$F_{yl1}(t) = \begin{cases} k_{dl} b_D [h_{Dl}(t) - \Delta h_l(t) + \Delta h_l(t - \tau_l)] & \text{for } h_{Dl}(t) - \Delta h_l(t) + \Delta h_l(t - \tau_l) > 0, \\ 0 & \text{for } h_{Dl}(t) - \Delta h_l(t) + \Delta h_l(t - \tau_l) \leq 0, \end{cases} \quad (2)$$

$$F_{yl2}(t) = \begin{cases} \mu_l k_{dl} b_D [h_{Dl}(t) - \Delta h_l(t) + \Delta h_l(t - \tau_l)] & \text{for } h_{Dl}(t) - \Delta h_l(t) + \Delta h_l(t - \tau_l) > 0, \\ 0 & \text{for } h_{Dl}(t) - \Delta h_l(t) + \Delta h_l(t - \tau_l) \leq 0, \end{cases} \quad (3)$$

$$F_{yl3}(t) = 0, \quad (4)$$

where k_{dl} is the average dynamic specific cutting pressure; $h_{Dl}(t)$ – the desired cutting layer thickness, $h_{Dl}(t) = f_z \sin \kappa_r \cos \varphi_l(t) (\Delta b \cong 0)$; $\Delta h_l(t)$ – dynamic change

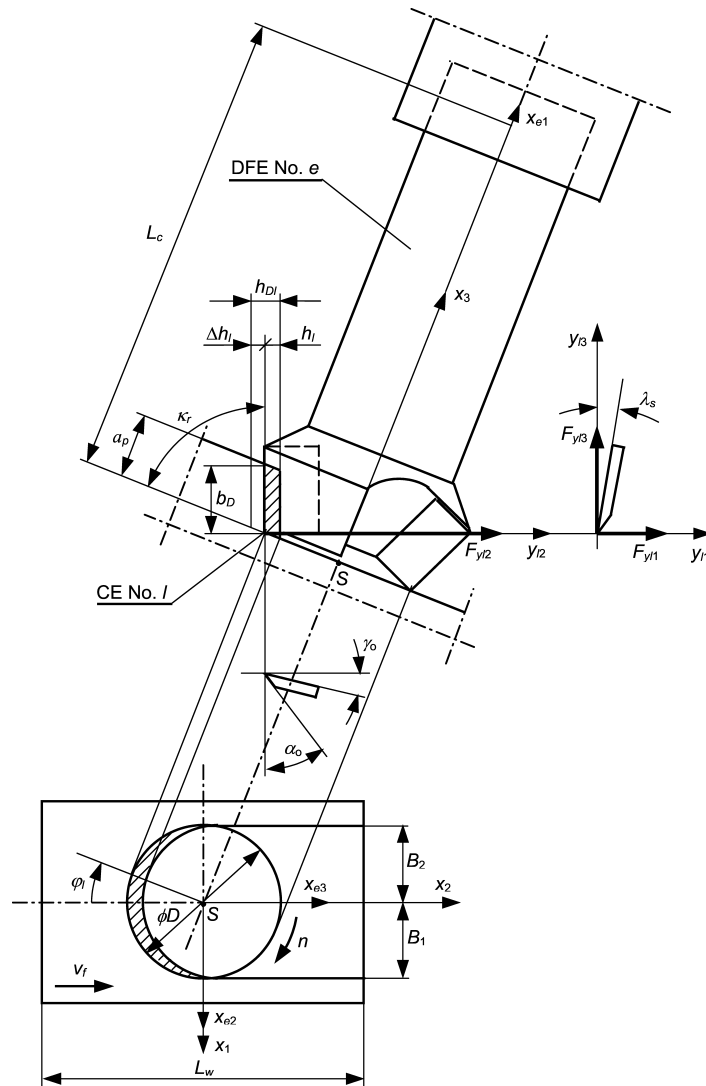

Figure 2. A scheme of the process of face milling by a slender-end mill

in thickness of the cutting layer for time instant t ; $\Delta h_l(t - \tau_l)$ – dynamic change in thickness of the cutting layer for time instant $t - \tau_l$; τ_l – time delay between the same position of CE no. l and of the previous one (CE no. $l - 1$); μ_l – the cutting force ratio; f_z – feed per tooth.

Zero values of the components indicate loss of contact between the tool and the workpiece.

If we suppose that spindle speed changes instantaneously with respect to angular position, φ (i.e. $n = n(\varphi)$), time τ_l can be determined from the formula:

$$\tau_l = \int_{\varphi_l - \varphi_{0l}}^{\varphi_l} \frac{60}{2\pi} \cdot \frac{d\varphi}{n(\varphi)}, \quad (5)$$

where φ_l is the current angular position of CE no. l ; φ_{0l} – the difference between the same angular position of CE no. l and CE no. $l-1$; $n(\varphi)$ – instantaneous spindle speed as a function of angular position φ .

After transformation of displacements into a generalised x_1, x_2, x_3 co-ordinate system of the conventional point S , an equation of dynamics shall have the following form [1, 2]:

$$\mathbf{M}\ddot{\mathbf{q}} + \mathbf{L}\dot{\mathbf{q}} + \mathbf{K}^*(t)\mathbf{q} = \mathbf{f}^*, \quad (6)$$

where

$$\begin{aligned} \mathbf{K}^*(t) &= \mathbf{K} + \sum_{l=1}^{i_l} \mathbf{T}_l^T(t) \mathbf{D}_{Pl} \mathbf{T}_l(t), \\ \mathbf{f}^* &= \mathbf{f}_0 + \sum_{l=1}^{i_l} \mathbf{T}_l^T(t) \mathbf{D}_{Ol} \Delta \mathbf{w}_l(t - \tau_l), \\ \mathbf{f}_0 &= \sum_{l=1}^{i_l} \mathbf{T}_l^T(t) \mathbf{F}_l^0(t), \end{aligned}$$

and \mathbf{q} is the vector of the generalised co-ordinates of the system; $\mathbf{M}, \mathbf{L}, \mathbf{K}$ – matrices of inertia, damping and stiffness of the mechanical system; $\mathbf{F}_l^0(t)$ – vector of the desired cutting forces of CE no. l ; \mathbf{D}_{Pl} – matrix of the proportional feedback coefficients of CE no. l ; \mathbf{D}_{Ol} – matrix of the delayed feedback coefficients of CE no. l ; $\Delta \mathbf{w}_l(t - \tau_l)$ – vector of deflections of CE no. l for time instant $t - \tau_l$; i_l – number of “active” coupling elements (CE).

The matrix of transformation $\mathbf{T}_l(t)$ is time-dependent because several edges of the cutter change their positions due to motion of the spindle and the workpiece. This means that the system becomes a system with time-varying coefficients of matrix \mathbf{K}^* .

4. Tool-workpiece relative vibration surveillance through spindle speed optimal control [1, 12]

Here, the problem of spindle speed optimal control during the cutting process is formulated. It is assumed that cutting is executed at a changing spindle speed, n . In this case, time delay τ_l for edge no. l (Equation (5)) becomes a function of instantaneous spindle speed n , *i.e.* $\tau_l = \tau_l(n)$. As a result of an instantaneous change in spindle speed, δn , Equation (6) shall assume the following form:

$$\mathbf{M}\ddot{\mathbf{q}} + \mathbf{L}\dot{\mathbf{q}} + \mathbf{K}^*(t)\mathbf{q} = \sum_{l=1}^{i_l} \mathbf{T}_l^T(t) \mathbf{F}_l^{(0)}(t) + \sum_{l=1}^{i_l} \mathbf{T}_l^T(t) \mathbf{D}_{Ol} \Delta \mathbf{w}_l' \left(t - \int_{\varphi_l - \varphi_{0l}}^{\varphi_l} \frac{60}{2\pi} \cdot \frac{d\varphi}{n(\varphi)} \right). \quad (7)$$

It has been shown [1] that the dynamics of the cutting process (Equation (7)) with changing spindle speed can be represented using the description of a controlled multibody system [1, 12], where the control matrix is:

$$\mathbf{B}_u(t) = \sum_{l=1}^{i_l} \mathbf{T}_l^T(t) \mathbf{D}_{Ol} \Delta \dot{\mathbf{w}}_l \left(t - \int_{\varphi_l - \varphi_{0l}}^{\varphi_l} \frac{60}{2\pi} \cdot \frac{d\varphi}{n(\varphi)} \right) \cdot \left[-\frac{\Delta t}{n(\varphi_l)} \right] \quad (8)$$

and the control command is:

$$\mathbf{u} \equiv \delta n. \quad (9)$$

It follows from Equations (8) and (9) that spindle speed optimal control depends upon instantaneous change, δn , in spindle speed, $n(t)$, introduced as a command.

The following surveillance procedure is suggested in view of the foregoing.

- *On-line* computer simulation of spindle speed optimal control. As a result, a changing spindle speed programme is obtained.
- *Chatter* detection: spectral analysis and time-plot analysis.
- *On-line* control of a real structure using the changing spindle speed programme.

5. Tool-workpiece relative vibration surveillance through step-changing spindle speed control [1, 13]

Let us now analyse the milling process again and assume that spindle speed, $n(t)$, changes with time in accordance with the following inertia step relationship:

$$n(t) = \begin{cases} n_0 & \text{for } 0 \leq t \leq t_1, \\ n_{j-1} + (n_j - n_{j-1}) \cdot \left(1 - e^{-\frac{t-t_{j-1}}{T_j}}\right) & \text{for } t_{j-1} \leq t \leq t_j, \quad j = 2, \dots, N, \end{cases} \quad (10)$$

where n_0 is the nominal (initial) spindle speed; T_j – time constant of stage no. j of step-changing spindle speed; t_j – switching time of stage no. j of step-changing spindle speed.

The problem of vibration surveillance is formulated as follows.

Adjust a sequence of spindle speeds, n_1, n_2, \dots, n_N , for values from a switching time set $\{t_1, t_2, \dots, t_N\}$ and subsequently perform the process for the determined parameter values.

For this purpose, a set of design variables is defined:

$$\mathbf{X} = \{X_1 \quad X_2 \quad \dots \quad X_N\}, \quad (11)$$

where $X_1 = n_1, X_2 = n_2, \dots, X_N = n_N$. The design variables are constrained by the following equations (for $i = 1, \dots, N$):

$$\begin{cases} X_i - n_{\max} \leq 0, \\ -X_i + n_{\min} \leq 0. \end{cases} \quad (12)$$

The min and max subscripts refer to minimum and maximum values of spindle speed, $n(t)$. Switching times $\{t_1, t_2, \dots, t_N\}$ should be adjusted so that the machine tool's main driving system and the spindle speed control system should be capable of performing them.

The cost function is defined as:

$$F(\mathbf{X}) = \sum_{i=0}^{m_i} [\mathbf{q}_{t_i} - \bar{\mathbf{q}}_{t_i}]^T \hat{\mathbf{Q}} [\mathbf{q}_{t_i} - \bar{\mathbf{q}}_{t_i}], \quad (13)$$

where $m_i + 1$ is the number of points of the time plot in the time interval $\langle t_0, t \rangle$; \mathbf{q}_{t_i} – vector of generalised displacements of the system for time instant t_i ; $\bar{\mathbf{q}}_{t_i}$ – vector of generalised displacements of the system for time instant t_i at the desired motion; $\hat{\mathbf{Q}}$ – the matrix of weighing coefficients, which should be minimised with respect to design variables \mathbf{X} .

The following surveillance procedure is proposed in view of the foregoing.

- *Off-line* determination of step-changing spindle speed parameters.
- Vibration monitoring by measuring the tool's displacement with proximity sensors.
- *Chatter* detection: an analysis of time plots with low-pass and band-pass filters or with spectral analysis.
- Programme-controlled spindle speed *on-line*: computer simulation or real machining performance.

Programme-controlled spindle speed can be easily realised in modern milling machines (*e.g.* the VMC FADAL 4020HT machine tool) using a software controller [1, 13]. A special computer code is started from an external PC. It generates step-changing spindle speed (control command), the values of which are switched in minimum time of 0.08s and transmitted to the machine through the RS232 port. It appears to be a very economical solution, as it only makes use of the standard driving and control systems of the machine, with no necessity to modify the structure. An instantaneous change in spindle speed by about ± 350 rev/min at the time constant value of 0.1s is obtainable on a real machine tool.

6. Computer simulation of tool-workpiece vibration surveillance

A computer simulation of face-milling vibration surveillance on a VMC FADAL 4020HT machine has been performed using a NOMA 206.016 W-W slender-end mill and a non-stationary model of the cutting process.

The specimen is made of carbon steel. The following data have been introduced: nominal spindle speed of revolution $n_0 = 3000$ rev/min, feed speed $v_f = 600$ mm/min, number of indexable inserts of the mill (cover material: TiN) $z = 2$, mill diameter $D = 16$ mm, widths of cutting $B_1 = B_2 = 8$ mm, length of cutting $L_w = 60$ mm, and main cutting angle $\kappa_r = 90^\circ$.

Tool vibration along direction x_1 is calculated. In order to evaluate the vibration level, the root mean square (*RMS*) value of a time plot is defined as follows:

$$RMS = \sqrt{\frac{1}{i_\alpha} \sum_{\alpha=1}^{i_\alpha} q_{1\alpha}^2}, \quad (14)$$

where $q_{1\alpha}$ is the vibration at point α of a time plot along direction x_1 ; i_α is the number of points of a time plot along direction x_1 .

Milling with a depth of $a_p = 0.3$ mm is a case of stable cutting (Figure 3a). The presumed *chatter* resonant peaks are almost unnoticeable. Cutting with increased depth (*i.e.* $a_p = 0.5$ mm) leads to a loss of stability and the appearance of strong *chatter* vibration (Figure 3b). Two dominant *chatter* resonant frequencies have been determined.

The efficiency of surveillance is assessed on the basis of the F_{RMS} ratio of vibration:

$$F_{RMS} = \frac{RMS}{RMS_0}, \quad (15)$$

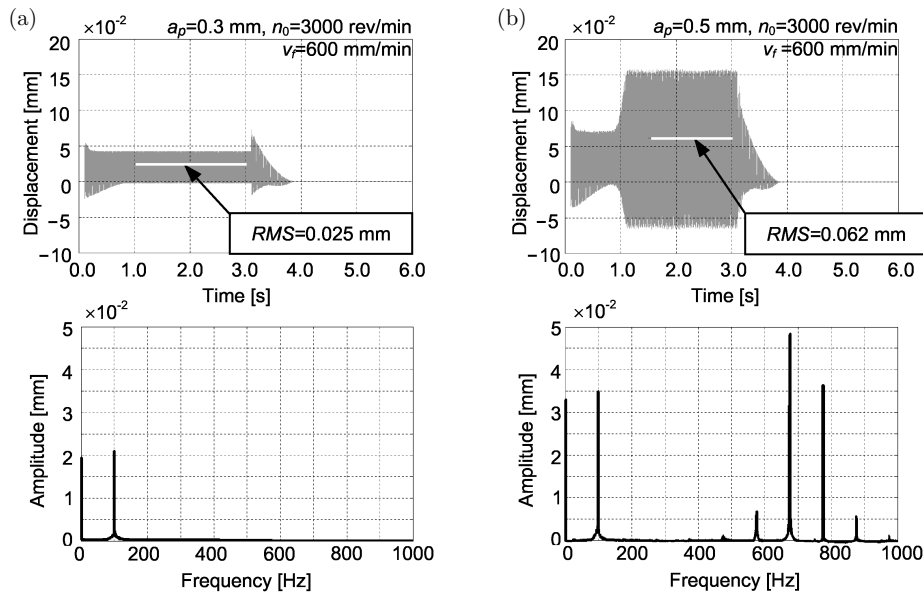

Figure 3. Results of computer simulation of tool vibration along direction x_1 , no surveillance: (a) stable cutting; (b) *chatter* vibration

where RMS_0 denotes the *RMS* of the vibration plot without surveillance, and *chatter* amplitude ratio along direction x_1 , as follows:

$$F_{ch} = \frac{q_{1ch}^0}{q_{1ch0}^0}, \quad (16)$$

where q_{1ch}^0 is the dominant *chatter* amplitude along direction x_1 ; q_{1ch0}^0 – the dominant *chatter* amplitude along direction x_1 without surveillance.

Two sets of computer simulation results, as shown in Figure 4, refer to two programmes of spindle speed change, *i.e.* spindle speed optimal control and step-changing spindle speed control. Both cases are evidence that the method of the proposed computer simulation is applicable, as the changing spindle speed programme has been successfully applied to a real milling machine and *chatter* vibration has been reduced. The latter is indicated both by the *RMS* factor F_{RMS} (reduction by about 30%) and by the *chatter* amplitude factor F_{ch} (almost complete reduction).

7. A prediction procedure for tool-workpiece vibration surveillance results [1, 14]

Despite the possibility of direct real performance of the developed strategy of programmed spindle speed, a preliminary computer prediction of the results is suggested. The main reason is that the computer simulation appears to be more economical than a real cutting process, which may be a source of considerable savings in technology. Thanks to fast computer devices and software, many machining alternatives for various cutting parameters can also be examined in short time. Finally, real performance is applied as a result of the delivered concept, and chances of making any mistakes are greatly reduced. Therefore, the following procedure is suggested for the prediction of tool-workpiece vibration surveillance results.

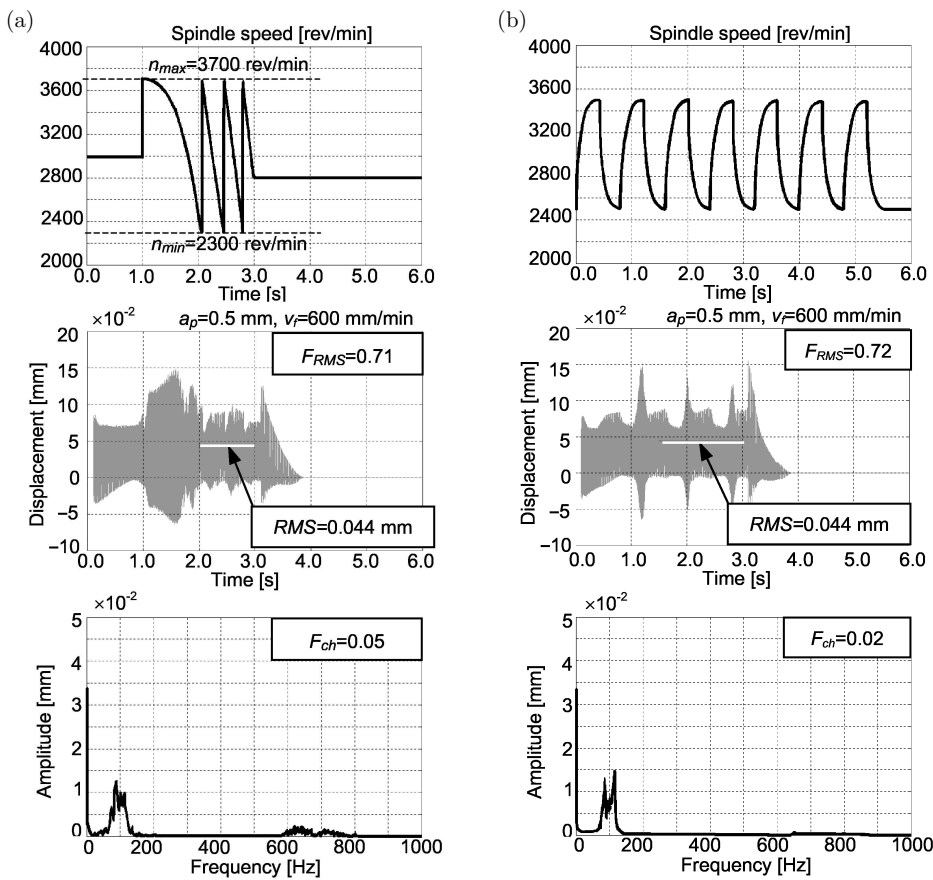

Figure 4. Results of a computer simulation of tool transverse vibration surveillance of the face milling process: (a) spindle speed optimal control; (b) step-changing spindle speed control, switching time 0.4s, time constant 0.08s

- Determination of the model parameters, based upon a comparison of frequency characteristics (measured and simulated) during vibrations without surveillance. Based upon the introduced milling model, the following parameters are sufficient in order to match the plots: the average dynamic specific cutting pressure, k_{dl} , the cutting force ratio, μ_l , and the damping constant of the tool material, η .
- Matching the step changing speed plots to those resulting from the changing spindle speed programme. Inertia of the real main driving system (time constant about 0.1s) should be considered as well.
- Evaluation of the quality of time plots and frequency characteristics obtained after application of the programme-controlled spindle speed strategy.
- Comparison of results of vibration surveillance, predicted and actually obtained.

Illustrative example. A computer simulation is performed of face milling vibration surveillance in a VMC FADAL machine using a NOMA 206.016 W-W slender-end mill, designed for high-speed cutting, and considering a non-stationary model of the process (Equation (6)). The specimen is made of carbon steel. The data being intro-

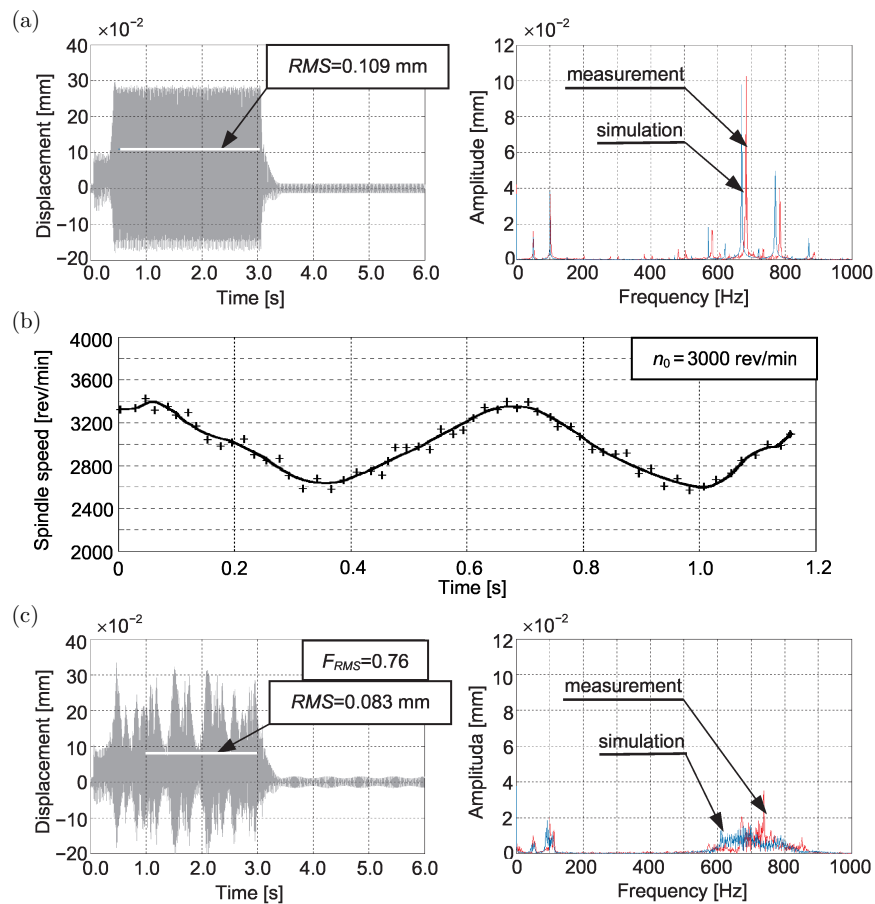

Figure 5. Results of a computer simulation and comparison of frequency plots of tool transverse vibration in the face milling process: (a) no vibration surveillance; (b) performance of the machine tool changing spindle speed programme, switching time 0.125s; (c) vibration surveillance at switching time 0.125s

duced are as per Chapter 6, except for feed speed, $v_f = 1200$ mm/min, and length of cutting, $L_w = 60$ mm. Experimental results have been obtained for these parameter values [1, 14]. Vibration along direction x_1 is calculated. The choice is very convenient, because it provides opportunities for comparison of the simulated results with those obtained from measurements.

Cutting with a depth of $a_p = 0.2$ mm leads to a loss of stability and the appearance of a strong, developed *chatter* vibration (Figure 5a). In the range of two-edge cutting, the level of vibration has reached about 0.300 mm, at $RMS = 0.109$ mm. Two resonant frequency values are dominant in the amplitude spectrum. Maximum resonance amplitude is over 0.100 mm.

Using the trial-and-error approach, the following parameters have been determined for the simulation: specific dynamic cutting pressure $k_{dl} = 2.3 \cdot 10^9$ N/m², cutting force ratio $\mu_l = 0.4$, and a damping constant of the tool material of $\eta = 1.4 \cdot 10^7$ Ns/m. Good agreement between the measured and simulated frequency curves has been obtained as a result (Figure 5a).

Following that, the model with the determined parameter values has been employed for computer prediction of results of programme-controlled spindle speed performance (Figure 5b). Selected data for the examined strategy are scheduled below (Table 1).

Table 1. Selected parameters for programme-controlled spindle speed

| No. | Change of spindle speed n | n_j [rev/min] | t_j [s] | T_j [s] |
|-----|-----------------------------|---|--------------------------------|-----------|
| 1 | Step-changing | 3350, 3000, 2650, 3000, 3350, 3000,... | 0.125, 0.25, 0.375, 0.5,... | 0.1 |

The parameters values have been typed, so that the method can be applied to a real milling machine. The results of computer simulations of the above strategy have shown that (Figure 5c):

- the *RMS* value of the time plot is reduced to 0.083mm,
- maximum resonance amplitudes are reduced a few times,
- actual behaviour of the milling process has been predicted. The latter is supported by a comparison of the frequency plots obtained from the simulation and measurements.

8. Conclusions

Results of the computer simulation have demonstrated very good efficiency of the strategy of vibration surveillance by spindle speed optimal control and step-changing spindle speed control. Peak values of resonant *chatter* vibration have been reduced almost completely. The *RMS* values have also been significantly decreased. The strategy appears to be fully efficient for surveillance of vibration observed during real machining operations. The application of computer simulation tools has also allowed us to generate a changing spindle speed programme, so that the subsequent application of vibration surveillance on real structures will be an effect of the developed concept. The proposed strategy of suppressing the *chatter* vibration can be applied with success, as its efficiency is observed throughout the machining process.

The method of prediction of tool-workpiece vibration surveillance by a programme-controlled spindle speed strategy has been developed in the paper and the results have been successfully verified. The importance of the tool-workpiece vibration surveillance methodology has been emphasised from the view-point of its usefulness for both computer prediction and real performance. Thus, the goal of determining optimal spindle speeds in order to minimise tool-workpiece vibration during the cutting process has been reached.

Suitable computer simulations, in which the original software had been applied, allowed us to accurately predict the course of a real cutting process. Further development of the research will focus on the implementation of the strategies described in the paper for surveillance of vibration observed during various machining operations.

References

- [1] Kaliński K 2001 *Vibration Surveillance of Mechanical Systems which are Idealised Discretely*, The Publication of Gdansk University of Technology (in Polish)
- [2] Kaliński K 1999 *Advances in Technology of the Machines and Equipment* **23** (3) 17

- [3] Smith S and Tlustý J 1990 *Trans. ASME J. Engng. for Industry* **112** 142
- [4] Jemielniak K and Widota A 1984 *Int. J. Mach. Tool Des. a. Res.* **24** (3) 207
- [5] Lin S C, DeVor R E and Kapoor S G 1990 *Trans. ASME J. Engng. for Industry* **112** 1
- [6] Altintas Y and Chan P K 1992 *Int. J. Mach. Tools Manufact.* **32** (3) 329
- [7] Soliman E and Ismail F 1997 *Int. J. Mach. Tools Manufact.* **37** (3) 355
- [8] Liao Y S and Young Y C 1996 *Int. J. Mach. Tools Manufact.* **36** (5) 651
- [9] Schulz H 1997 *Proc. I France and German Conf. High Speed Machining*, Université de Metz, Metz, France **I** pp. 1–7
- [10] Kaliński K 1997 *Int. J. Mech. Science* **39** (3) 315
- [11] Tomków J 1997 *Vibro-stability of Machine Tools*, The Scientific and Technical Publication (in Polish)
- [12] Kaliński K J 2003 *Int. J. Mech. Prod. Sys. Engng.* **Avril** 30
- [13] Kaliński K J, Kucharski T and Sawiak S 2001 *Proc. 3rd Int. Conf. Metal Cutting and High Speed Machining*, Ecole Nationale d'Ingenieurs de Metz, Metz, France **I** (PMAC4) pp. 241–250
- [14] Kaliński K and Kucharski T 2000 *Proc. 2nd Int. Seminar on Improving Machine Tool Performance*, Nantes: Ecole Centrale, La Baule, France **A25** (CD-ROM)

