

MEMBRANE-HANGING ROOF ANALYSIS: AN EXAMPLE

ANDRZEJ AMBROZIAK

*Department of Structural Mechanics and Bridges Structures,
Faculty of Civil and Environmental Engineering,
Gdansk University of Technology,
Narutowicza 11/12, 80-952 Gdansk, Poland
ambrozan@pg.gda.pl*

(Received 13 June 2006)

Abstract: The paper presents an analysis of a membrane-hanging roof subjected to climatic loadings. Discussion of the fundamental equations of the dense net model, used to describe the behaviour of coated woven fabric, and the concept of the climatic loadings is included.

Keywords: membrane structures, FEM, Forest Opera, MSC.Marc

1. Introduction

Rapid development of computational tools has made it possible to apply numerical methods in engineering mechanics. The finite element method (FEM), the finite-difference method and the boundary elements method have become the main procedures of structural numerical analysis (see *e.g.* [1]). At present, FEM is the most popular method (see *e.g.* [2, 3]). However, while FEM has many advantages, it has to be applied properly. It is an approximate method, so its calculation results refer to idealised structural models instead of real structures.

The paper is a presentation of geometrically non-linear analysis of a membrane-hanging roof made of coated woven fabric. Coated woven fabrics consist of a thread net of polyester or glass fibers coated on both sides with a plastic material, *e.g.* polyvinyl chloride (PVC) or polytetrafluoroethylene (PTFE, see *e.g.* [4, 5]).

2. The dense net model

A numbers of theoretical models have been developed to describe the complex behaviour of coated woven fabrics (see *e.g.* [6] or [7]), where several variants of constitutive models are discussed). From the wide range of available constitutive models, the dense net model has been chosen here [8, 9], which assumes that warp

and weft threads are subjected to uni-axial tension and the stresses in a given family of threads depend on strains in the same direction only (see Figure 1), so that:

$$\boldsymbol{\sigma} = \underbrace{\begin{bmatrix} 1 & \cos^2 \alpha \\ 0 & \sin^2 \alpha \\ 0 & \sin \alpha \cos \alpha \end{bmatrix} \begin{bmatrix} F_1(\gamma_1) & 0 \\ 0 & F_2(\gamma_2) \end{bmatrix} \begin{bmatrix} 1 & 0 & 0 \\ \cos^2 \alpha & \sin^2 \alpha & \sin \alpha \cos \alpha \end{bmatrix}}_D \begin{Bmatrix} \varepsilon_{xx} \\ \varepsilon_{yy} \\ \gamma_{xy} \end{Bmatrix} = \mathbf{D}\boldsymbol{\varepsilon}, \quad (1)$$

where $F_1(\gamma_1)$ and $F_2(\gamma_2)$ are the components of the elasticity matrix (experimentally determined from the uni-axial tension tests in the warp and weft directions). The elasticity matrix can be calculated as:

$$\mathbf{D} = \begin{bmatrix} F_1(\gamma) + F_2(\gamma) \cos^4 \alpha & F_2(\gamma) \sin^2 \alpha \cos^2 \alpha & F_2(\gamma) \sin \alpha \cos^3 \alpha \\ F_2(\gamma) \sin^2 \alpha \cos^2 \alpha & F_2(\gamma) \sin^4 \alpha & F_2(\gamma) \sin^3 \alpha \cos \alpha \\ F_2(\gamma) \sin \alpha \cos^3 \alpha & F_2(\gamma) \sin^3 \alpha \cos \alpha & F_2(\gamma) \sin^2 \alpha \cos^2 \alpha \end{bmatrix}. \quad (2)$$

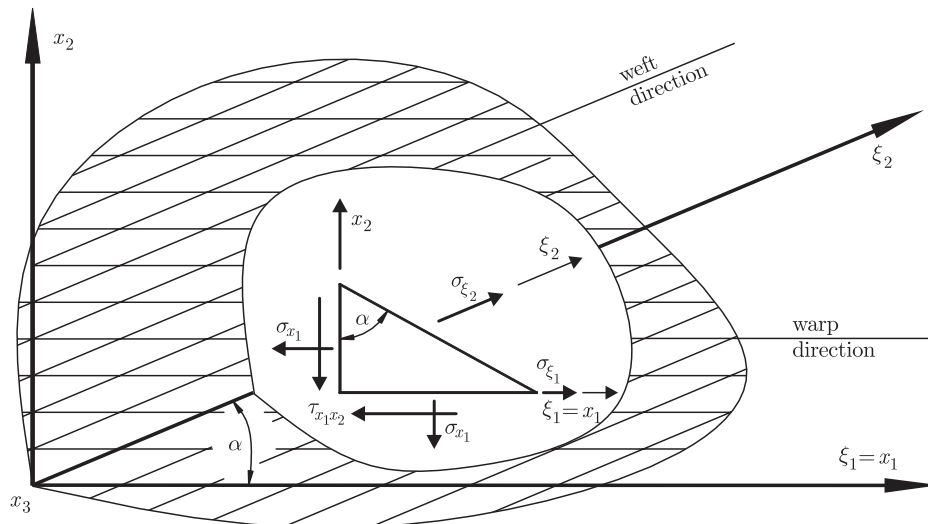

Figure 1. The dense net model

It should be noted that the angle, α , between the families of threads (warp and weft), changes during deformation and may be calculated from the following equation:

$$\alpha = \arctan \left(\frac{\sigma_{x_1}}{\tau_{x_1 x_2}} \right). \quad (3)$$

3. Material parameters

The present paper is based on laboratory tests performed by Zagubiń for the Panama fabric [10]. Typical results of the uni-axial tension tests are presented in Figure 2. The Panama fabric consisted of polyester fibres (PES) and was coated with PVC on both sides. The fabric's elastic properties in the warp and weft direction are given in Table 1.

Table 1. Elasticity modulus of the Panama fabric [11]

Parameters	Values	Strain range
F_{warp}	904kN/m	$0 < \varepsilon < 0.0119$
	176kN/m	$\varepsilon \geq 0.0119$
F_{weft}	187kN/m	$0 < \varepsilon < 0.039$
	146kN/m	$\varepsilon \geq 0.039$

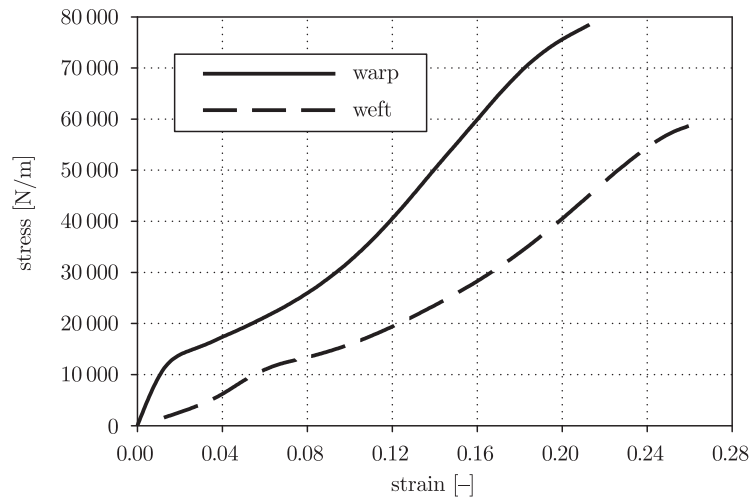

Figure 2. Typical results of the uniaxial tension tests for Panama fabric

4. Climatic loadings

One of the problems in analyses of membrane hanging roofs is a lack of detailed standards to determine the values of climatic loading. The author has used the concept of calculating the snow and wind loadings proposed in [12].

Snow loading, corresponding to the horizontal projection of a membrane roof, is calculated from the following equation:

$$S = \gamma_f \cdot 1.2 \cdot S_k = 1.4 \cdot 1.2 \cdot Q_k \cdot C = 1.68 \cdot Q_k \cdot C, \tag{4}$$

where Q_k is a characteristic value of snow loading [N/m²]. Factor C (a coefficient of the roof's shape) is proposed according to Figure 3 (see [12] for details).

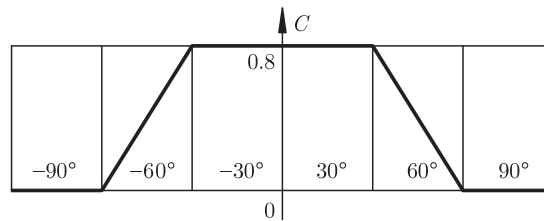

Figure 3. Diagram of the C factor evolution – snow loading

The intensity of wind, g , acting perpendicularly to the roof's surface is specified as:

$$p = \gamma_f \cdot p_k = 1.3 \cdot q_k \cdot C_e \cdot C \cdot \beta, \tag{5}$$

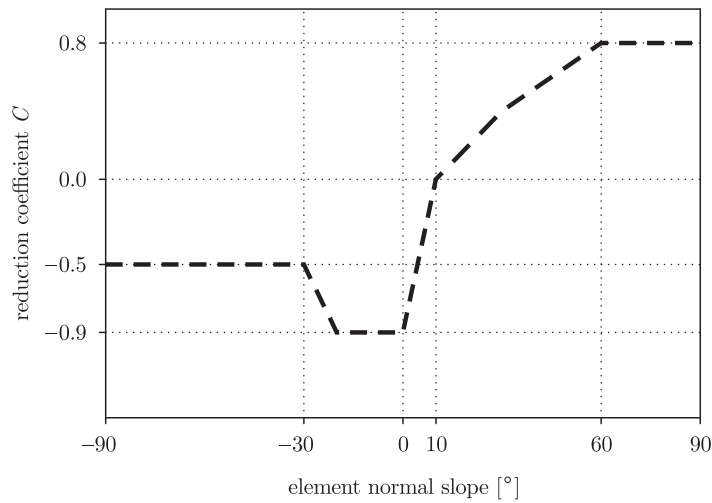

Figure 4. Diagram of the C factor evolution – wind loading

where p_k [N/m^2] is the characteristic value of wind loading, C_e is the exposition factor, and β is the blast of wind coefficient. Reduction factor C has been assumed according to Figure 4 (see *e.g.* [12–14] for details).

5. Procedures and methodology

The MSC.Marc commercial program was used in numerical calculations, with the HOOKLW [15] and FORCEM [15] user-defined subroutines. (On another occasion, the author has also successfully used the UVSCPL subroutine to implement the elasto-viscoplastic Chaboche and Bodner-Partom models into the MSC.Marc system, see [16–18]). Where the sub-structure of the coated woven fabric is described in the present analysis, 4-node isoparametric membrane elements are applied (see Figure 5 and [19, 20]).

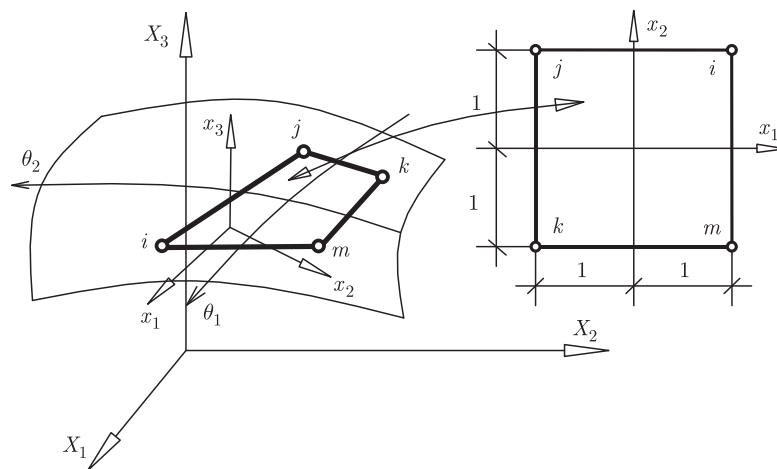

Figure 5. Four node membrane element

6. Numerical example

The presented numerical calculations are a preliminary variant of a new roof design for the Forest Opera in Sopot, Poland (see Figures 6 and 7). Their aim was to verify Panama fabric as a material of hanging roof cover. The fixed boundary conditions were assumed in the arc and the columns.

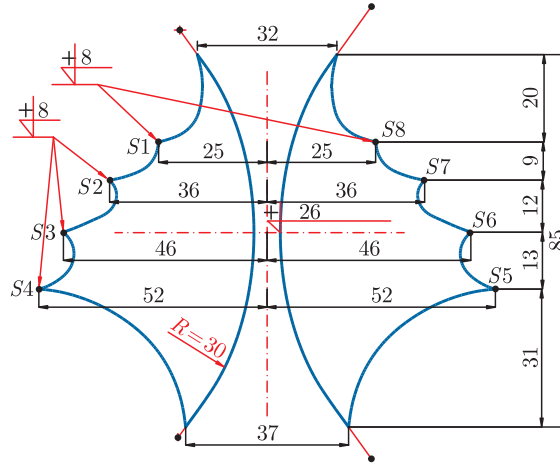

Figure 6. Geometry of the membrane hanging roof

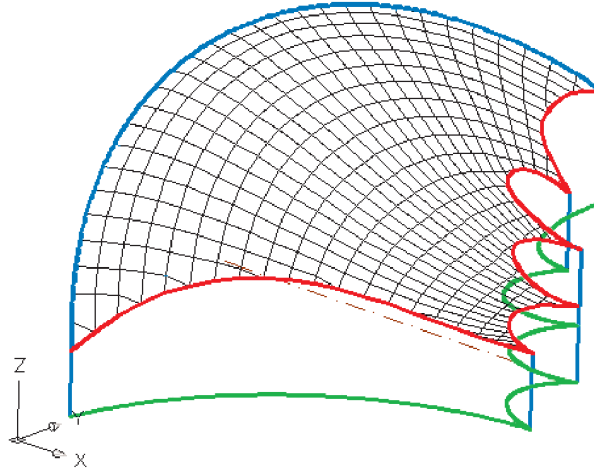

Figure 7. Initial mesh of the FEM

In the numerical simulations, the roof was subjected to deadweight loading, pretension forces and climatic loadings. Wind loading was assumed to act in the direction of the X axis. In the initial configuration, the Panama fabric threads had the global coordinate system's XY directions (X for warp and Y for weft). Pretension forces of 6 kN/m and 4 kN/m were applied in the initial configuration of membrane elements. Moreover, the surface edges were assumed to be bounded with PV40 and PV150 steel edge ropes.

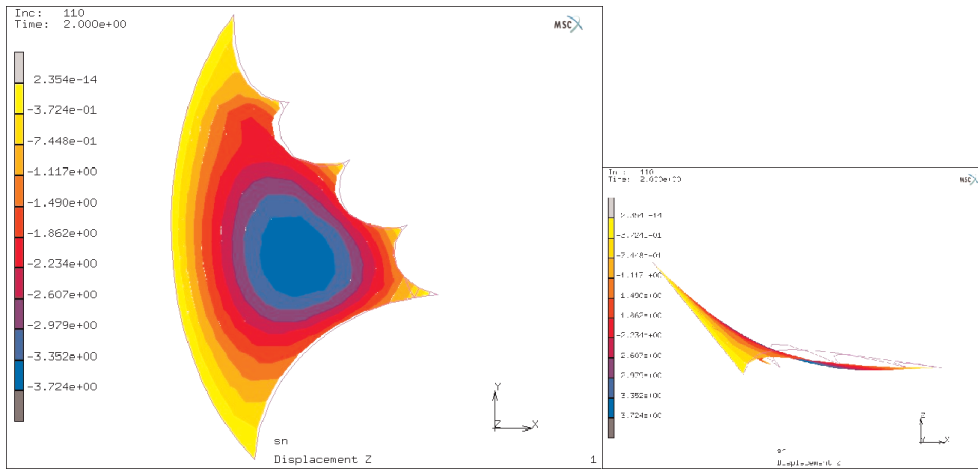

Figure 8. Deformation of the roof subjected to snow loading

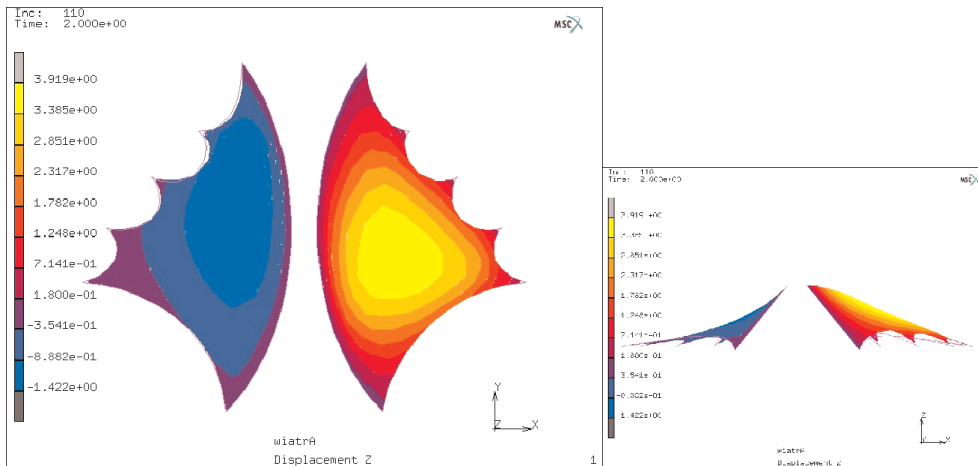

Figure 9. Deformation of the roof subjected to wind loading

The roof's deformation under the characteristic values of snow and wind loading is presented in Figures 8 and 9. The maximum displacement Z is -3.72m in the case of snow loading and -1.42m (pressure) or $+3.92\text{m}$ (suction) in the case of wind loading.

7. Conclusion and final remarks

The main disadvantage of the presented structural solution is its considerable deformability under snow and wind loading. A membrane roof made of Panama fabric would not fulfil the design requirements. Under snow loading we would observe the development of a huge snow bag (see Figure 8), which may be remedied by:

- 1) introducing additional cables to transfer a part of the loading from the membrane roof to the cables, and
- 2) using another type of coated fabric, for example a PTFE-coated fabric made of glass fibers.

Acknowledgements

The calculations presented in the paper were performed at the Academic Computer Centre in Gdansk (TASK).

References

- [1] Kleiber M 1995 *Computer Methods in Solid Mechanics*, vol. XI, PWN, Warsaw (in Polish)
- [2] Zienkiewicz O C and Taylor R L 2000 *Finite Element Method*, 5th Edition, Butterworth-Heinemann, Oxford
- [3] Bathe K J, Ramm E and Wilson E L 1975 *Int. J. Num. Meth. Eng.* **1** 353
- [4] Houtman R and Orpara M 2000 *Bauen mit Textilien* **4** 27
- [5] Schock H J 1991 *J. Coated Fabrics* **20** 277
- [6] Ambroziak A and Kłosowski P 2003 *Workshop on Advanced Mechanics of Urban Structures*, Sopot, Poland, pp. 145–148
- [7] Ambroziak A and Kłosowski P 2005 *Int. Coll. IASS Polish Chapter „Lightweight Structures in Civil Engineering”* (Obrębski J B, Ed.), Warsaw, Poland, pp. 99–102
- [8] Branicki C and Kłosowski P 1983 *Arch. Civil Eng.* **29** 189 (in Polish)
- [9] Branicki C 1969 *Some Static Problems of Hanging Nets*, PhD Thesis, Gdansk University of Technology, Poland (in Polish)
- [10] Zagubień A 2002 *Laboratory Tests and Identification of Inelastic Properties of Panama Coated Fabric*, PhD Thesis, Koszalin University of Technology, Koszalin (in Polish)
- [11] Ambroziak A 2005 *TASK Quart.* **2** 167
- [12] Ambroziak A, Kłosowski P and Nowicki M 2005 *Inżynieria i Budownictwo* **1** 42 (in Polish)
- [13] Ambroziak A and Kłosowski P 2005 *Inżynieria i Budownictwo* **2** 85 (in Polish)
- [14] Ambroziak A and Kłosowski P 2005 *Inżynieria i Budownictwo* **7** 383 (in Polish)
- [15] Users handbook: *MSC.Marc Volume D: User Subroutines and Special Routines, Version 2005*, MSC.Software Corporation 2005
- [16] Ambroziak A 2005 *TASK Quart.* **2** 157
- [17] Ambroziak A 2005 *Balkema – Proceedings and Monographs in Engineering, Water and Earth Sciences* (Pietraszkiewicz W and Szymczak C, Eds), Taylor & Francis Group, pp. 445–449
- [18] Ambroziak A 2006 *Comput. Assist. Mech. Eng. Sci.* (in print)
- [19] Ambroziak A and Kłosowski P 2006 *TASK Quart.* (in print)
- [20] Ambroziak A and Kłosowski P 2005 *Proc. 5th Int. Conf. on Comp. of Shell and Spatial Struct.*, Salzburg, Austria (CD publ.)

