

VARIATIONAL METHOD OF FINDING STREAMLINES IN RING CASCADES FOR CREEPING FLOWS

KRZYSZTOF TESCH AND MARZENA BANASZEK

*Gdansk University of Technology,
Department of Turbomachinery and Fluid Mechanics,
Narutowicza 11/12, 80-233 Gdansk, Poland
krzyte@pg.gda.pl*

(Received 7 January 2011; revised manuscript received 28 January 2011)

Abstract: This paper presents a new analytical method of finding streamlines for creeping flows in a ring cascade composed of an infinite number of infinitely thin blades. An analytical solution was obtained by minimizing the dissipation functional by means of the variational calculus. The necessary condition for the optimum of the functional yields the Stokes equation after certain additional assumptions are introduced. We considered different variants of fixing of the inlet and outlet of the cascade.

Keywords: variational calculus, creeping flow, dissipation

Notation

\mathbf{D} – strain-rate tensor
 D^{ij} – strain-rate tensor components
 f, F – function
 \vec{g} – acceleration due to gravity
 g – metric-tensor determinant
 g^{ij} – metric-tensor components
 J – functional
 N_d – dissipation power
 N – dissipation functional
 p – pressure
 r – radius
 R_1 – inner radius (outlet)
 R_2 – outer radius (inlet)
 Re – Reynolds number
 U_r – radial velocity component
 U_φ – angular velocity component
 U^i, U_i – i^{th} velocity component
 x^i – i^{th} coordinate

- α – inlet angle
- β – outlet angle
- γ_1 – outlet position (angle)
- γ_2 – inlet position (angle)
- Γ_{jk}^i – Christoffel symbols
- μ – dynamic viscosity
- τ – pitch
- ρ – density
- φ – angle
- ϕ_μ – dissipation function
- ψ – stream function
- Ω – considered flow domain

- ∇^4 – bilaplacian operator
- \sphericalangle – angle (α or β)

1. Introduction

Creeping, steady-state flow is considered, together with the additional assumption of axial symmetry. Creeping flow occurs when $\text{Re} \ll 1$. This condition, however, is not satisfied for typical technical applications in cascade flows. Therefore, the methods presented here are mostly of cognitive and academic value. Despite the fact that the assumption of $\text{Re} \ll 1$ is not satisfied for cascade flow, there are other interesting applications of this type of flows (see [1, 2]). A very important feature of creeping flows is worth mentioning here, *i.e.* they are characterized by the minimum possible dissipation. This feature follows from Helmholtz's theorem [3].

Firstly, we present the governing equations along with their representation by means of stream functions. Secondly, we give the analytical solution in terms of the velocity field. This solution was utilized to validate the variational solution discussed later. The variational method consists in minimizing the dissipation functional, which is also presented here. This functional takes several forms depending on the exact way the ends are fixed. A discussion of the relationship between the dissipation functional and the equation of motion follows. Finally, several solutions are presented.

Certain analytical solutions of similar problems involving bladeless ring cascades can be found in [4, 5]. New analytical solutions presented here apply to cascades made of an infinite number of infinitely thin blades. Also, a new, analytical method of finding streamlines is discussed here. This method is far more general than the direct solution of the governing equations in terms of the velocity field.

1.1. Conservation equation in curvilinear coordinate systems

Because of the shape of the cascade (see Figure 1), it is most convenient to express the conservation equations in a coordinate system in which they exhibit the simplest form. The mass conservation equation for the incompressible case

does not simplify, however, under the $Re \ll 1$ assumption. In any curvilinear coordinate system, it reads:

$$\frac{\partial}{\partial x^i} (\sqrt{g} U^i) = 0 \tag{1}$$

The Navier-Stokes equations without nonlinear terms simplify to:

$$g^{jk} \frac{\partial p}{\partial x^j} = \frac{2\mu}{\sqrt{g}} \frac{\partial (\sqrt{g} D^{ik})}{\partial x^i} + 2\mu D^{il} \Gamma_{il}^k \tag{2}$$

Also, the assumptions of incompressibility and constant viscosity μ were introduced along with the steady-state character of the flow. The strain-rate tensor is given by:

$$D^{ik} = \frac{1}{2} g^{il} g^{km} \left(\frac{\partial U_m}{\partial x^l} + \frac{\partial U_l}{\partial x^m} \right) - g^{il} g^{km} \Gamma_{lm}^j U_j \tag{3}$$

In cylindrical coordinates (or polar on a plane), we have $r := x^i$, $\varphi := x^2$, $z := x^3$. The metric tensor in this case takes the form:

$$(g^{ij}) = \begin{pmatrix} 1 & 0 & 0 \\ 0 & r^{-2} & 0 \\ 0 & 0 & 1 \end{pmatrix} \tag{4}$$

The determinant of the metric tensor is written here as $g = |(g^{ij})^{-1}| = r^2$. The nonzero Christoffel symbols are $\Gamma_{22}^1 = -r$, $\Gamma_{12}^2 = \Gamma_{21}^2 = \frac{1}{r}$. Therefore, the mass conservation equation (1) and the two components of the Stokes equations (2) for the directions r and φ can be now rewritten as:

$$\frac{\partial}{\partial r} (r U_r) + \frac{\partial U_\varphi}{\partial \varphi} = 0 \tag{5a}$$

$$\frac{1}{\mu} \frac{\partial p}{\partial r} = \frac{1}{r} \frac{\partial}{\partial r} \left(r \frac{\partial U_r}{\partial r} \right) + \frac{1}{r^2} \frac{\partial^2 U_r}{\partial \varphi^2} - \frac{U_r}{r^2} - \frac{2}{r^2} \frac{\partial U_\varphi}{\partial \varphi} \tag{5b}$$

$$\frac{1}{\mu} \frac{\partial p}{\partial \varphi} = \frac{\partial}{\partial r} \left(r \frac{\partial U_\varphi}{\partial r} \right) + \frac{1}{r} \frac{\partial^2 U_\varphi}{\partial \varphi^2} - \frac{U_\varphi}{r} + \frac{2}{r} \frac{\partial U_r}{\partial \varphi} \tag{5c}$$

The above system (5) is closed. The unknown functions are the velocity components U_r , U_φ and pressure p . The uniqueness of this system with prescribed boundary conditions was first proved by Helmholtz [6].

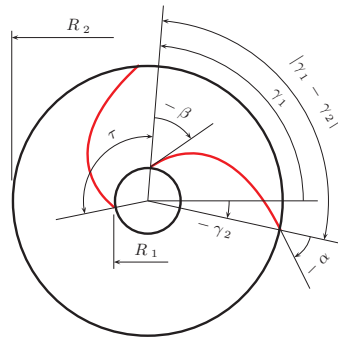

Figure 1. Scheme and description

The concept of the stream function ψ can be introduced according to the following definitions: $U_r = \frac{1}{r} \frac{\partial \psi}{\partial \varphi}$ and $U_\varphi = -\frac{\partial \psi}{\partial r}$. The alternative definitions: $U_r = -\frac{1}{r} \frac{\partial \psi}{\partial \varphi}$ and $U_\varphi = \frac{\partial \psi}{\partial r}$ are also possible. Both definitions satisfy the mass conservation Equation (5a). After differentiating Equation (5b) with respect to φ and (5c) with respect to r and subsequent subtracting one from the other, we obtain:

$$\frac{1}{r} \frac{\partial}{\partial r} \left(r \frac{\partial}{\partial r} \left(\frac{1}{r} \frac{\partial}{\partial r} \left(r \frac{\partial \psi}{\partial r} \right) \right) \right) + \frac{2}{r^2} \frac{\partial^4 \psi}{\partial r^2 \partial \varphi^2} + \frac{1}{r^4} \frac{\partial^4 \psi}{\partial \varphi^4} - \frac{2}{r^3} \frac{\partial^3 \psi}{\partial r \partial \varphi^2} + \frac{4}{r^4} \frac{\partial^2 \psi}{\partial \varphi^2} = 0 \quad (6)$$

The above equation is the so-called biharmonic equation in polar coordinates. A shorter version of this equation reads $\nabla^4 \psi = 0$. Goursat [7] proved that a general solution of this equation exists. We point out that although Equation (6) corresponds to the system (5), it is of fourth order.

1.2. Dissipation function and dissipation power

In polar, physical coordinates, the strain rate tensor (3) takes the form:

$$\mathbf{D} = \begin{pmatrix} \frac{\partial U_r}{\partial r} & \frac{1}{2} \frac{\partial U_\varphi}{\partial r} + \frac{1}{2r} \frac{\partial U_r}{\partial \varphi} - \frac{U_\varphi}{2r} \\ \frac{1}{2} \frac{\partial U_\varphi}{\partial r} + \frac{1}{2r} \frac{\partial U_r}{\partial \varphi} - \frac{U_\varphi}{2r} & \frac{1}{r} \frac{\partial U_\varphi}{\partial \varphi} + \frac{U_r}{r} \end{pmatrix} \quad (7)$$

The same tensor expressed in terms of the stream function ψ reads:

$$\mathbf{D} = \begin{pmatrix} \frac{1}{r} \frac{\partial^2 \psi}{\partial r \partial \varphi} - \frac{1}{r^2} \frac{\partial \psi}{\partial \varphi} & \frac{1}{2r^2} \frac{\partial^2 \psi}{\partial \varphi^2} + \frac{1}{2r} \frac{\partial \psi}{\partial r} - \frac{1}{2} \frac{\partial^2 \psi}{\partial r^2} \\ \frac{1}{2r^2} \frac{\partial^2 \psi}{\partial \varphi^2} + \frac{1}{2r} \frac{\partial \psi}{\partial r} - \frac{1}{2} \frac{\partial^2 \psi}{\partial r^2} & \frac{1}{r^2} \frac{\partial \psi}{\partial \varphi} - \frac{1}{r} \frac{\partial^2 \psi}{\partial r \partial \varphi} \end{pmatrix} \quad (8)$$

By means of this tensor, it is possible to express the dissipation function $\phi_\mu = 2\mu \mathbf{D}^2$ as [3]:

$$\phi_\mu = \frac{\mu}{r^4} \left(4 \left(\frac{\partial \psi}{\partial \varphi} - r \frac{\partial^2 \psi}{\partial r \partial \varphi} \right)^2 + \left(\frac{\partial^2 \psi}{\partial \varphi^2} + r \left(\frac{\partial \psi}{\partial r} - r \frac{\partial^2 \psi}{\partial r^2} \right) \right)^2 \right) \quad (9)$$

The dissipated power is defined as:

$$N_d = \iint_{\Omega} \phi_\mu r \, dr \, d\varphi \quad (10)$$

where the considered flow domain Ω is the following subset of the plane $\Omega := \{(r, \varphi) : r \in [R_1, R_2]; \varphi \in [0, \tau]\}$.

2. Analytical solutions

In this section, we discuss the analytical solution of the system (5) for an axially symmetric geometry. This case can also be regarded as a cascade composed of an infinite number of infinitely thin blades. Formally, this is the case where all the streamlines are identical with respect to rotation around the symmetry axis. From this arises an additional assumption, *i.e.* $\frac{\partial}{\partial \varphi} = 0$.

It may be shown that for axial symmetry, there exists a solution of the system (5). This system now simplifies to:

$$\frac{d}{dr} (r U_r) = 0 \quad (11a)$$

$$\frac{1}{\mu} \frac{dp}{dr} = \frac{1}{r} \frac{d}{dr} \left(r \frac{dU_r}{dr} \right) - \frac{U_r}{r^2} \quad (11b)$$

$$0 = r \frac{d^2 U_\varphi}{dr^2} + \frac{dU_\varphi}{dr} - \frac{U_\varphi}{r} \quad (11c)$$

We are dealing with ordinary differential equations. The first one, *i.e.* Equation (11a), can be integrated and gives the analytical solution $U_r = c_1 r^{-1}$. This solution can be substituted into Equation (11b). This results in $\frac{dp}{dr} = 0$, which means that the pressure is constant in the entire flow domain, $p = c_2$. The last Equation (11c) is an ordinary differential equation in terms of U_φ . Its solution takes the form $U_\varphi = c_3 r^{-1} + c_4 r$. Finally, the system (11) is integrated to:

$$U_r = \frac{c_1}{r} \quad (12a)$$

$$p = c_2 \quad (12b)$$

$$U_\varphi = \frac{c_3}{r} + c_4 r \quad (12c)$$

In view of the axial symmetry, the biharmonic equation $\nabla^4 \psi = 0$ (6) simplifies to:

$$\frac{1}{r} \frac{d}{dr} \left(r \frac{d}{dr} \left(\frac{1}{r} \frac{d}{dr} \left(r \frac{d\psi}{dr} \right) \right) \right) = 0 \quad (13)$$

This is also the case with the strain rate tensor (8), which takes the following form:

$$\mathbf{D} = \begin{pmatrix} \frac{\partial U_r}{\partial r} & \frac{1}{2} \frac{\partial U_\varphi}{\partial r} - \frac{U_\varphi}{2r} \\ \frac{1}{2} \frac{\partial U_\varphi}{\partial r} - \frac{U_\varphi}{2r} & \frac{U_r}{r} \end{pmatrix} \quad (14)$$

Following the same line of reasoning, the dissipation function (9) simplifies to:

$$\phi_\mu = \frac{\mu}{r^4} \left(2 \left(\frac{\partial \psi}{\partial \varphi} \right)^2 + 2 \left(\frac{\partial \psi}{\partial \varphi} - r \frac{\partial^2 \psi}{\partial r \partial \varphi} \right)^2 + r^2 \left(\frac{\partial \psi}{\partial r} - r \frac{\partial^2 \psi}{\partial r^2} \right)^2 \right) \quad (15)$$

3. Dissipation functional

The assumption of axial symmetry results in a set of identical streamlines f , which depend only on the coordinate r . The following form of the stream function ψ may be proposed [3]:

$$\psi(r, \varphi) := \frac{\varphi - f(r)}{\tau} \quad (16)$$

It cannot be determined whether this function satisfies the biharmonic Equation (13), since the function f is unknown. The problem is now reduced to the search for the single-variable function f instead of the two-variable function ψ . The form of ψ (16) is fully determined by f .

3.1. Form of the functional

The dissipation function (15) or (9) takes the following form by virtue of (16):

$$\phi_\mu = \frac{\mu}{r^4 \tau^2} \left(4 + r^2 (f' - r f'')^2 \right) \quad (17)$$

The dissipation power (10) may now be rewritten as an iterated integral for any pitch τ (Figure 1):

$$N_d = \int_0^\tau \int_{R_1}^{R_2} \phi_\mu r dr d\varphi \quad (18)$$

What is important is that the form (16) allows us to integrate the dissipation power once, since it explicitly depends on φ . On the basis of Equations (17) and (18), we have:

$$N_d = \frac{\mu}{\tau} \int_{R_1}^{R_2} \frac{1}{r^3} \left(4 + r^2 (f' - r f'')^2 \right) dr \quad (19)$$

The above integral is a certain functional which depends on the radius r and the function f together with its derivatives (up to the second). Symbolically, this can be written as:

$$N[f] = \int_{R_1}^{R_2} F(r, f, f', f'') dr \quad (20)$$

The necessary condition for the optimum of this functional, in the general case with unconstrained ends, takes the form [8]:

$$\int_{R_1}^{R_2} \left(\frac{\partial F}{\partial f} - \frac{d}{dr} \frac{\partial F}{\partial f'} + \frac{d^2}{dr^2} \frac{\partial F}{\partial f''} \right) \delta f dr + \left(\frac{\partial F}{\partial f'} - \frac{d}{dr} \frac{\partial F}{\partial f''} \right) \delta f \Big|_{R_1}^{R_2} + \frac{\partial F}{\partial f''} \delta f' \Big|_{R_1}^{R_2} = 0 \quad (21)$$

Therefore, the optimization problem consists in the search for a streamline f which would minimize the functional (20). The form of the function f results from the necessary condition (21). This condition can simplify, if certain additional assumptions are introduced. This is discussed later.

3.2. Dissipation functional vs. equations of motion

The method presented here consists in choosing the function f (streamlines) which would minimize the functional (19). However, the essential question is whether the solution obtained by minimizing the functional satisfies the equations of motion (11). To answer this question, we need the functional which yields the Stokes equations as a result of a necessary condition. The general form of this functional is [3]:

$$J = \iint_{\Omega} \left(\rho \frac{\partial \vec{U}}{\partial t} \cdot \vec{U} - \rho \vec{g} \cdot \vec{U} - p \nabla \cdot \vec{U} + \mu \mathbf{D}^2 \right) d\Omega \quad (22)$$

The necessary condition $\delta J = \vec{0}$ yields the Stokes equations $\rho \frac{\partial \vec{U}}{\partial t} = \rho \vec{g} - \nabla p + \mu \nabla^2 \vec{U}$. In this case, we deal with steady-state flow $\frac{\partial}{\partial t} = 0$ and we neglect mass forces. In this case the functional (22) simplifies to:

$$J = \iint_{\Omega} \left(-p \nabla \cdot \vec{U} + \mu \mathbf{D}^2 \right) d\Omega \quad (23)$$

From the necessary condition, we obtain Equation (2) in absolute notation $\nabla p = \mu \nabla^2 \vec{U}$. From solution (12) of the system (11), it follows that the pressure is constant and therefore, $\nabla p = \vec{0}$ and $J = \iint_{\Omega} \mu \mathbf{D}^2 d\Omega$. This means that $2J = N_d$ where N_d is defined by means of (17)–(19). This guarantees that the minimization of the dissipation functional N_d , which yields the streamlines f , leads to a solution that satisfies the Stokes equation (for constant pressure). Additionally, one can consider only the cases with one end unconstrained and with both ends partially constrained (when the angles are known). This is discussed in Section 4. The above reasoning does not apply to the Navier-Stokes equations, since they are non-linear and there is no classical variational formulation such as (22) [9]. However, there is a non-classical variational formulation which can be used for the non-linear Navier-Stokes equations. This means that dissipation is not the only component of the functional and there is no guarantee that the streamlines f , which arise from the minimization of the functional, satisfy the equations of motion.

4. Streamlines

4.1. Both ends constrained

Here we deal with the case where the angle α and the position γ_2 are known at the inlet and the angle β and the position γ_1 (Figure 1) are known at the outlet. From the necessary condition (21), we obtain the Euler equation in the following form:

$$\frac{\partial F}{\partial f} - \frac{d}{dr} \frac{\partial F}{\partial f'} + \frac{d^2}{dr^2} \frac{\partial F}{\partial f''} = 0 \tag{24}$$

Since both ends are constrained, so are the appropriate variations $\delta f|_{R_i} = 0$ and $\delta f'|_{R_i} = 0$. From the Euler equation (24) for the functional F , we obtain an ordinary differential equation of the fourth order:

$$\frac{f'}{r^3} - \frac{f''}{r^2} + \frac{2f'''}{r} + f^{IV} = 0 \tag{25}$$

This equation should be solved together with the following boundary conditions $f(R_1) = \gamma_1$, $f(R_2) = \gamma_2$, $f'(R_1) = \tan\beta$, $f'(R_2) = \tan\alpha$. The general solution of Equation (25) is the function f (streamline):

$$f(r) := C_1 + C_2 r^2 + C_3 \ln r + C_4 r^2 \ln r \tag{26}$$

It can be easily verified that the solution (26) satisfies the biharmonic Equation (13). After calculating the stream function (16), the velocities U_r , U_φ and the pressure p , we find that the second equation of motion (11b) gives $0 = 4C_4 r^{-1}$. This means that the pressure does not satisfy the axial symmetry condition and thus the problem with both ends constrained is too general (too stiff). In addition, all the following solutions must satisfy the condition $C_4 = 0$. Only then, the axial

symmetry condition is satisfied for all the variables. Finally, the most general form of the solution of Equation (25) has the form:

$$f(r) := C_1 + C_2 r^2 + C_3 \ln r \quad (27)$$

4.2. One end partly constrained

Two cases are possible. In the first one, we know one of the angles α or β . In the second, we know the position γ_1 or γ_2 .

4.2.1. Known angle

Here, we know both angles: the inlet angle α and the outlet angle β . We look for one of the positions γ_i . This requires $\delta f'|_{R_i} = 0$ and $\delta f|_{R_1} \neq 0$ or $\delta f|_{R_2} \neq 0$. From the necessary condition (21), we obtain an additional equation:

$$\left(\frac{\partial F}{\partial f'} - \frac{d}{dr} \frac{\partial F}{\partial f''} \right) \Big|_{r=R_i} = 0 \quad (28)$$

The solution must satisfy this condition together with the Euler equation (24). It can be shown that the additional condition (28) for the functional F can be reduced to $-4C_4 r^{-2}|_{R_i} = 0$, which yields $C_4 = 0$. Therefore, the solution (26) takes the form (27). This means that the problem with one end partly constrained (with constrained position) is well-formulated.

The known position serves as a reference point and its value has no significance, owing to the axial symmetry of the function f . The boundary conditions take the form $f'(R_1) = \tan \beta$, $f'(R_2) = \tan \alpha$. For the sake of simplicity, the additional reference point can be assumed as $f(R_2) = 0$. In so doing we deal with two partly constrained ends (constrained position). The solution of Equation (27) together with the discussed boundary condition has the form:

$$f(r) := \frac{2R_1 R_2 (R_1 \tan \alpha - R_2 \tan \beta) \ln \frac{r}{R_2} - (r^2 - R_2^2) (R_2 \tan \alpha - R_1 \tan \beta)}{2(R_1^2 - R_2^2)} \quad (29)$$

By using formula (16) and the definition of the stream function it can be shown that the velocity $U_r = \tau^{-1} r^{-1}$. This means that the constant c_1 in Equation (12a) equals $c_1 = \tau^{-1}$. The velocity is then:

$$U_\varphi = \frac{1}{\tau(R_1^2 - R_2^2)} \left(r(R_1 \tan \beta - R_2 \tan \alpha) + \frac{R_1 R_2}{r} (R_1 \tan \alpha - R_2 \tan \beta) \right) \quad (30)$$

which means that the constants in Equation (12c) take the form:

$$c_3 = \frac{R_1 R_2 (R_1 \tan \alpha - R_2 \tan \beta)}{\tau (R_1^2 - R_2^2)} \quad (31)$$

$$c_4 = \frac{R_1 \tan \beta - R_2 \tan \alpha}{\tau (R_1^2 - R_2^2)}$$

On the basis of Equations (19) and (29) one can calculate the dissipated power. Figure 2 presents the dissipation power as a function of the angles α and β . The dissipation is dimensionless, that is to say it is divided by the value of

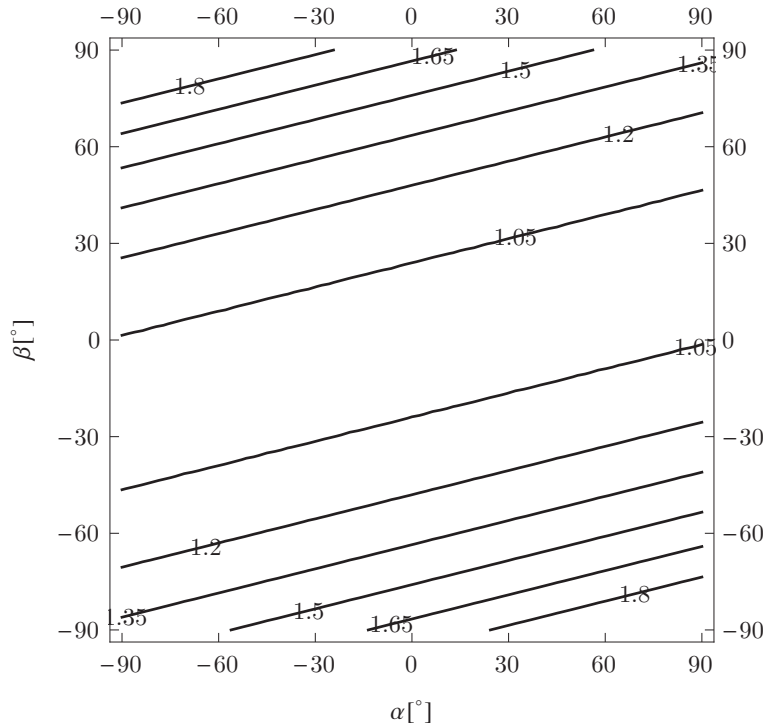

Figure 2. Dimensionless dissipation power as a function of the angles α and β for $\frac{R_2}{R_1} = 4$

the dissipation for $\alpha = \beta = 0^\circ$. There is no minimum value in the form of a point. However, there is a line of minimum dissipation crossing the point $(0^\circ, 0^\circ)$. Here, the slope is identical to that of the other isolines.

Figure 3 shows the wrap-around angle $|\gamma_1 - \gamma_2|$ as a function of the angles α and β . The minimum value was obtained for $\alpha = \beta = 0^\circ$. The largest values of the wrap-around angles $|\gamma_1 - \gamma_2| \rightarrow \infty$ are obtained for $(\alpha, \beta) \rightarrow (-90^\circ, -90^\circ)$ and $(\alpha, \beta) \rightarrow (90^\circ, 90^\circ)$.

The stream function ψ defined by Equation (16) is shown in Figure 4. Exemplary streamlines, obtained from Equation (29), are shown in Figure 6, where $\alpha = -80^\circ$. The outlet angles vary from -80° to 80° with a step of 10° .

4.2.2. Known position

Here, we know both positions: the inlet γ_2 and the outlet γ_1 . We look for either the inlet angle α or the outlet angle β . This requires that the variations $\delta f|_{R_i} = 0$ and $\delta f'|_{R_1} \neq 0$ or $\delta f'|_{R_2} \neq 0$. From the necessary condition (21), we obtain an additional equation in the following form:

$$\left. \frac{\partial F}{\partial f^n} \right|_{r=R_i} = 0 \quad (32)$$

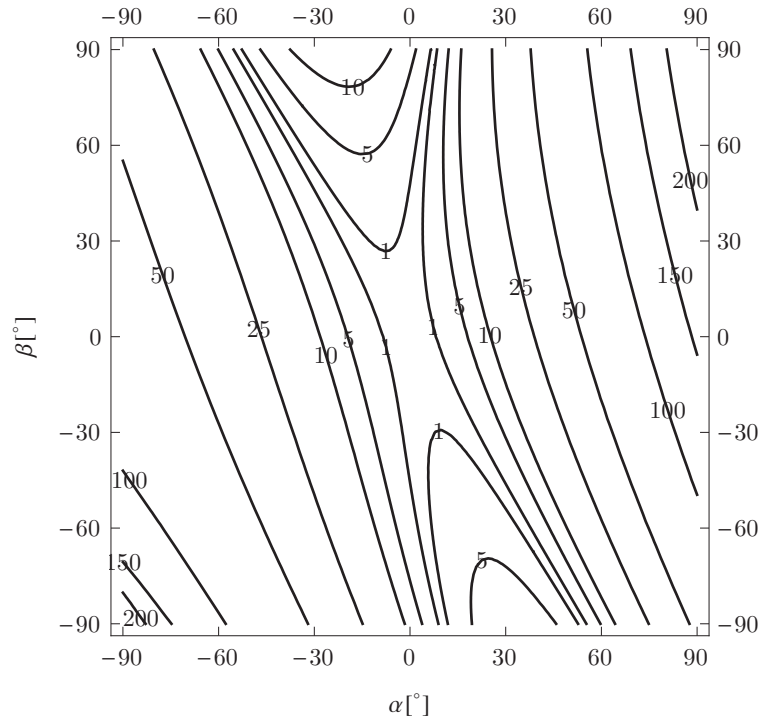

Figure 3. Wrap-around angle of the streamlines as a function of the angles α and β for $\frac{R_2}{R_1} = 4$

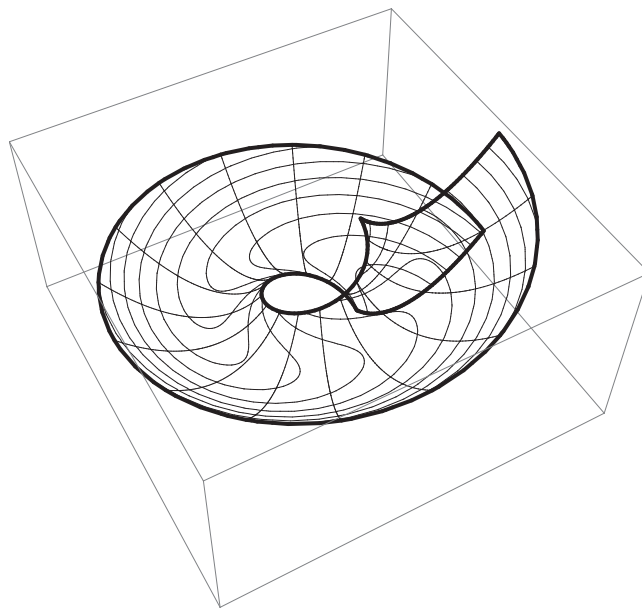

Figure 4. Stream function ψ for $\alpha = -80^\circ$, $\beta = 80^\circ$, $\frac{R_2}{R_1} = 4$

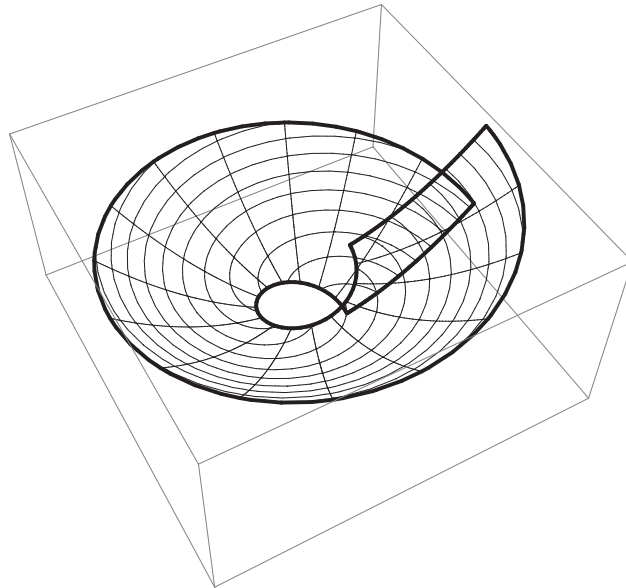

Figure 5. Stream function ψ for $\alpha = -80^\circ$ and $\frac{R_2}{R_1} = 4$

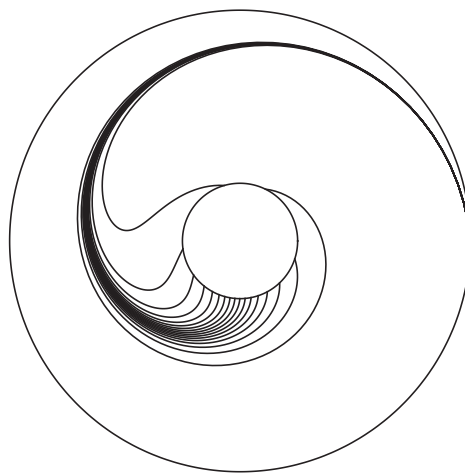

Figure 6. Streamlines as a function of β for $\alpha = -80^\circ$ and $\frac{R_2}{R_1} = 4$

which must be satisfied together with the Euler equation (24). The additional Equation (32) for the functional F simplifies to $C_3 = C_4 r^2|_{R_i}$. This leads to the following form of the streamline:

$$f(r) := C_1 + C_2 r^2 + C_4 (R_i^2 + r^2) \ln r \tag{33}$$

The above solution does not have the admissible form (27). This means that the pressure is not axially symmetric. Therefore, the case with one end partially constrained (in the form of a known angle) was too stiff and hence not well-formed ($C_3 = C_4 R_i^2 \neq 0$).

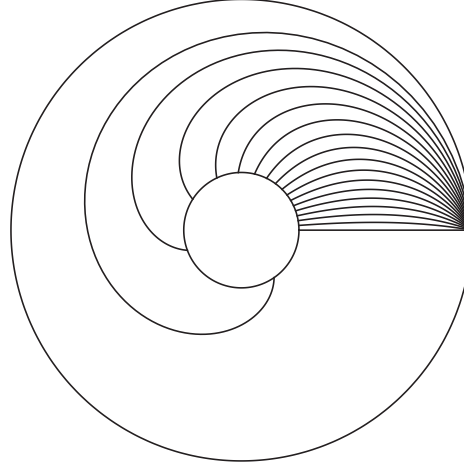

Figure 7. Streamlines as a function of the inlet angle α for $\frac{R_2}{R_1} = 4$

4.3. One end unconstrained

Here, we know either the inlet position γ_2 and inlet angle α or the outlet position γ_1 together with the outlet angle β . This requires that the variations $\delta f'|_{R_i} = 0$ and $\delta f|_{R_i} \neq 0$. Apart from the Euler equations (25), additional conditions (28) and (32) must be satisfied. This is the combination of the two previously discussed cases, where $C_3 = C_4 R_i^2 = 0$. From Equation (26) follows the general solution:

$$f(r) := C_1 + C_2 r^2 \quad (34)$$

The specific solution of (34) must satisfy the following boundary conditions $f(R_i) = \gamma_i$, $f'(R_i) = \tan \alpha$, where $R_i \in \{R_1, R_2\}$, $\alpha \in \{\alpha, \beta\}$. From this conditions we obtain the specific solution:

$$f(r) := \gamma_i + \frac{r^2 - R_i^2}{2R_i} \tan \alpha \quad (35)$$

The solution is valid both for the unconstrained inlet and the unconstrained outlet. From Equation (16) and the definition of the stream function, it follows that the velocity $U_r = \tau^{-1} r^{-1}$, which means that c_1 in Equation (12a) $c_1 = \tau^{-1}$. The velocity $U_\varphi = r R_i^{-1} \tau^{-1} \tan \alpha$, which means that the constants in the solution (12c) take the form $c_3 = 0$ i $c_4 = R_i^{-1} \tau^{-1} \tan \alpha$.

The dissipation power as a function of the inlet or outlet angle can be calculated on the basis of Equations (19) and (35). In both cases, this power is constant and for a pitch $\tau = 2\pi$ it equals:

$$N_d = \frac{\mu}{\pi} \left(\frac{1}{R_1^2} - \frac{1}{R_2^2} \right) \quad (36)$$

Figure 5 shows the distribution of the stream functions ψ calculated by means of Equation (16). The streamlines corresponding to the solution (35) are shown in Figure 7. This is the case with the unconstrained outlet. The shortest

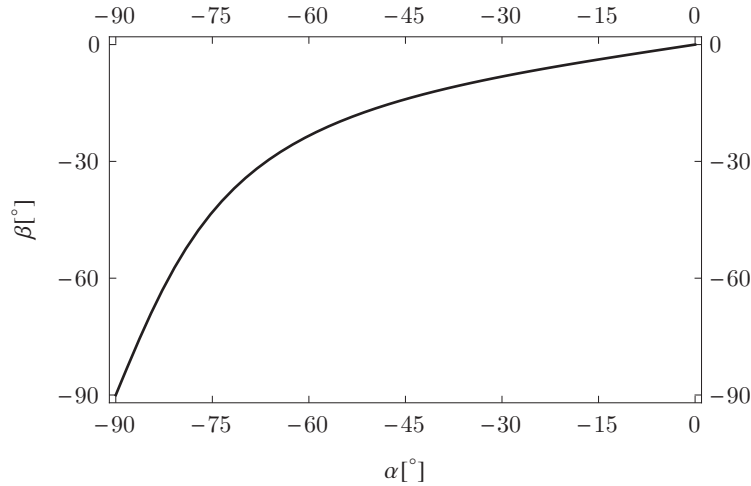

Figure 8. Outlet angle β as a function of the inlet angle α for $\frac{R_2}{R_1} = 4$

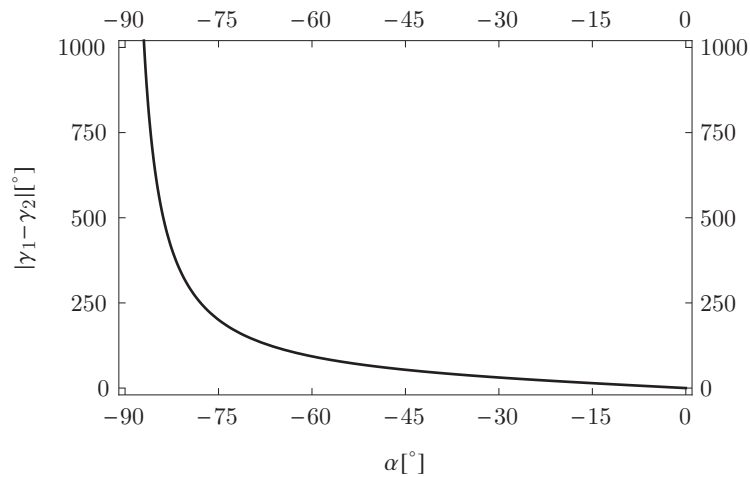

Figure 9. Wrap-around angle as a function of the inlet angle α for $\frac{R_2}{R_1} = 4$

streamlines are obtained for the angles 0° . The larger the angle (a step of 5° was used), the larger the wrap-around angle. Figure 8 presents the values of the unconstrained outlet angle β as a function of the inlet angle α . Figure 9 shows the distribution of the wrap-around angle $|\gamma_1 - \gamma_2|$ as a function of the inlet angle. For the extreme position $\alpha \rightarrow -90^\circ$, the wrap-around angle $|\gamma_1 - \gamma_2| \rightarrow \infty$.

5. Conclusions

It is possible to find an analytical solution of the Stokes equation for an axially symmetric geometry in terms of the velocity field. This can be done by direct integration of the system (11). Furthermore, it is even possible to find a solution of the biharmonic equation (13) using the proposed decomposition of

the stream function (16). Basing on these solutions, one cannot determine whether further relaxations of the inlet and outlet are possible, since there are no additional conditions that can be imposed on the solution. A far more general method was presented here that allowed us to overcome these difficulties. This method consists in the minimization of a dissipation functional by means of the variational calculus. This allows to formulate additional conditions to be imposed on the solution. Moreover, this method allows to obtain further solutions depending on how the inlet and the outlet are fixed and to find the solutions which are too stiff. Such analytical solutions were obtained and presented here. Also, a detailed discussion of the relationship between the dissipation functional and the Stokes equation was given in order to clarify when and where this method could be applied.

Acknowledgements

The authors would like to express their gratitude to Prof. R. Puzyrewski for his advice and helpful remarks.

References

- [1] Happel J and Brenner H 1981 *Low Reynolds Number Hydrodynamics*, Springer
- [2] Klonowska-Prosnak M E and Prosnak W J 2001 *Acta Mechanica* **146** (1–2) 115
- [3] Tesch K 2008 *Fluid Mechanics*, Gdansk University of Technology Publishing, Gdansk (in Polish)
- [4] Puzyrewski R and Tesch K 2010 *TASK Quart.* **14** (3) 67
- [5] Savage S B 1964 *J. Appl. Mech.* **31** 594
- [6] Helmholtz H 1882 *Wissenschaftliche Abhandlungen 1*, Barth J A, Leipzig
- [7] Goursat È 1898 *Bulletin de la Société Mathématique de France* **26** 236
- [8] Elsgolc L D 2007 *Calculus of Variations*, Dover Publications, Inc., New York
- [9] Glazunov Y 2000 *Variational Methods of Solving Differential Equations*, Gdansk University of Technology Publishing, Gdansk (in Polish)